

STRIEM



MANUFACTURERS OF
OIL SEPARATORS | SOLIDS INTERCEPTORS | CHEMICAL WASTE TANKS

PRODUCT CATALOG, NO.6

A NOTE FROM TWO BROTHERS.



WE LOVE MAKING PLUMBING PRODUCTS.

We formed Striem in 2015 with one idea in mind: dealing with a manufacturer should be like a breath of fresh air. That's why we implemented a simple formula:

- ✓ Build quality products,
- ✓ Ship them on time, and
- ✓ Provide damn good customer service.

We hope you enjoy working with us.

VINCE ISMERT
Direct: 816-591-9765

GABE ISMERT
Direct: 816-820-5454

TABLE OF CONTENTS

OIL SEPARATORS

- OS series5
- Oil Tanker™ series7
- Slick Stick™ oil level monitoring system9

SOLIDS INTERCEPTORS

- SIDEKICK™ point-of-use side-access 12
solids interceptors
- Aardvark™ basket style solids interceptors... 13
- Prospector™ screen style solids interceptors .. 15
- Settler™ catch basins 16

CHEMICAL WASTE TANKS

- Lab Rat™ under counter neutralization tanks .. 18
- Lab Basin™ centralized neutralization tanks .. 19
- Command Center™ pH monitoring package .. 21
- Bio Basin™ decontamination tanks..... 22

SAMPLE PORT

- Inspector™ sample port 23

ACCESSORIES

- Risers..... 24
- High water anchor kits 25
- Covers..... 26



913-222-1500 HELP@STRIEMCO.COM STRIEMCO.COM

CUSTOMER SERVICE HOURS: 8 AM - 5 PM CST

OIL SEPARATORS



OT-500 being moved with built-in Lifting Lug Kit

STRIEM'S OIL SEPARATOR FOOTPRINT

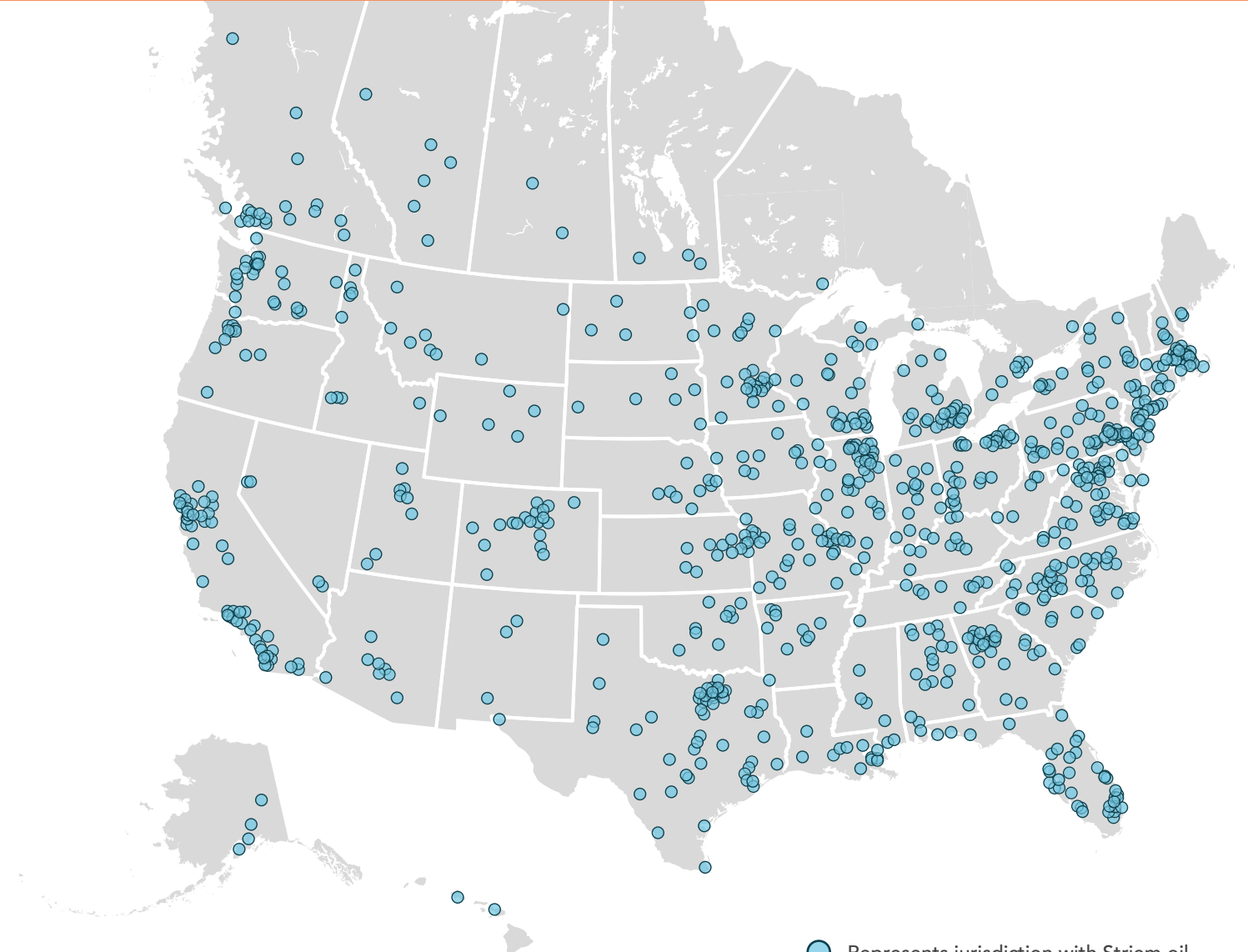

● Represents jurisdiction with Striem oil separator installation(s) since 2016.

APPLICATIONS



AUTO SERVICE/
REPAIR STATIONS



FIRE HOUSE/
POLICE STATIONS

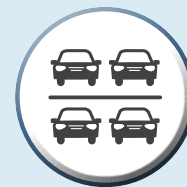

PARKING
GARAGES

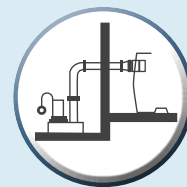

HYDRAULIC
ELEVATOR PITS



CAR WASHES



LOADING
DOCKS



AIRPORTS /
HANGARS

**FLOW RATE BASED
OIL SEPARATORS**

OS SERIES

CHECK OUT OUR
**ONLINE
SIZING TOOL.**

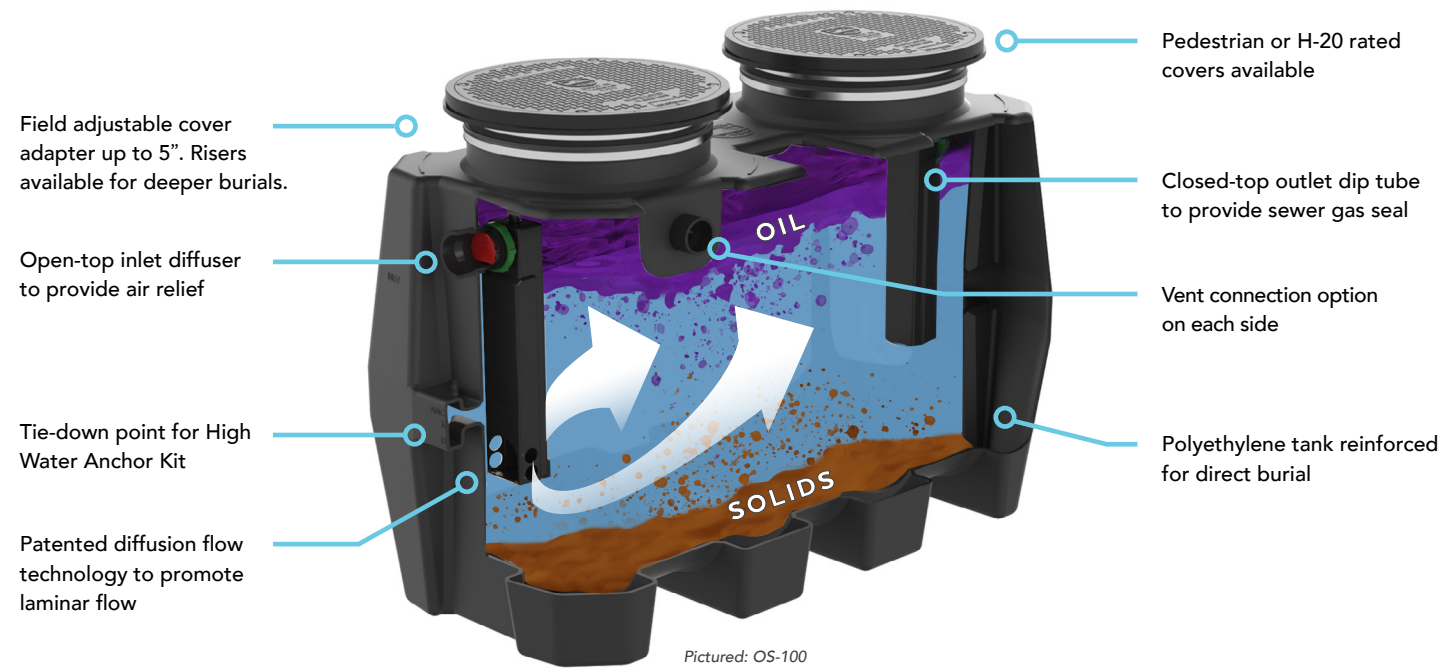

Pictured: OS-100

OPTIONS

Covers

See page 26 for more details

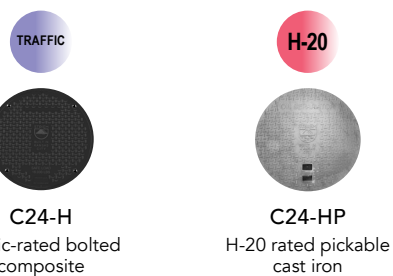

C24-H
Traffic-rated bolted
composite

C24-HP
H-20 rated pickable
cast iron

SR/LR field-adjustable extensions

See page 24 for more details

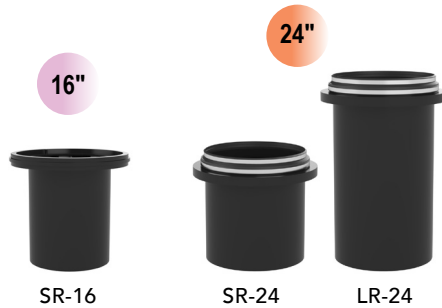

SR-16

SR-24

LR-24



Corrugated Pipe Riser Kit (CPRK)

See page 24 for more details



High water table hold down kits

See page 25 for more details



Slick Stick™ oil level monitoring system

See page 9 for more details

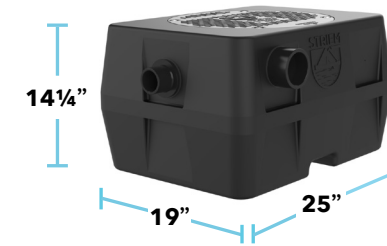

OS-15

16"

CONNECTIONS: 2", 3"
MAX FLOW RATE: 15 GPM
LIQUID CAPACITY: 15 GAL.
OIL CAPACITY: 10 GAL.
SAND CAPACITY: 1 GAL.
WEIGHT: 28 LBS.
COVER: PEDESTRIAN-RATED



OS-25

16"

CONNECTIONS: 2", 3"
MAX FLOW RATE: 25 GPM
LIQUID CAPACITY: 21 GAL.
OIL CAPACITY: 15 GAL.
SAND CAPACITY: 6 GAL.
WEIGHT: 31 LBS.
COVER: PEDESTRIAN-RATED

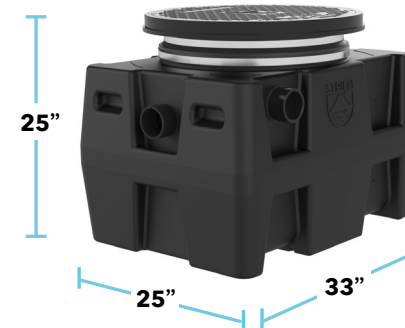

OS-35

24"

CONNECTIONS: 2", 3", 4"
MAX FLOW RATE: 35 GPM
LIQUID CAPACITY: 38 GAL.
OIL CAPACITY: 28 GAL.
SAND CAPACITY: 6 GAL.
WEIGHT: 77 LBS.
COVER: PEDESTRIAN-RATED

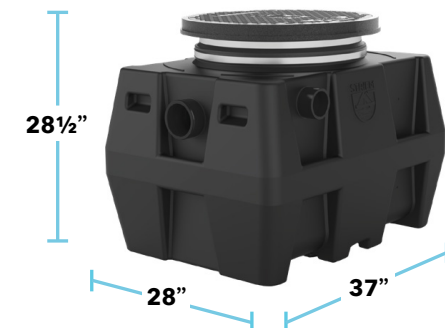

OS-50

24"

TRAFFIC H-20 HDK SS

CONNECTIONS: 2", 3", 4"
MAX FLOW RATE: 50 GPM
LIQUID CAPACITY: 57 GAL.
OIL CAPACITY: 40 GAL.
SAND CAPACITY: 7 GAL.
WEIGHT: 92 LBS.
COVER: PEDESTRIAN-RATED

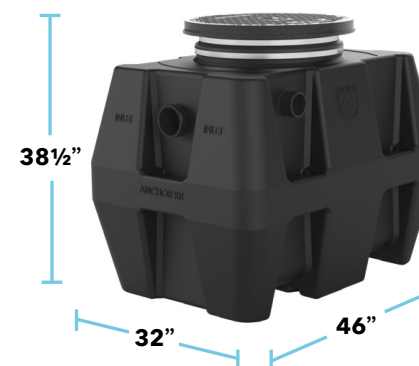

OS-75

24"

H-20 CPRK HDK SS

CONNECTIONS: 4", 6"
MAX FLOW RATE: 75 GPM
LIQUID CAPACITY: 110 GAL.
OIL CAPACITY: 93 GAL.
SAND CAPACITY: 11 GAL.
WEIGHT: 130 LBS.
COVER: TRAFFIC-RATED



OS-100

24"

H-20 CPRK HDK SS

CONNECTIONS: 4", 6"
MAX FLOW RATE: 100 GPM
LIQUID CAPACITY: 250 GAL.
OIL CAPACITY: 144 GAL.
SAND CAPACITY: 95 GAL.
WEIGHT: 230 LBS.
COVER: TRAFFIC-RATED

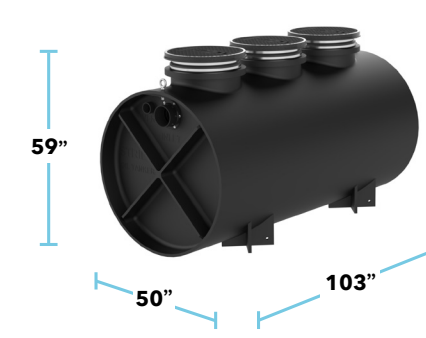

OT-500 24" CPRK HDK SS
CONNECTIONS: 4", 6", 8"
MAX FLOW RATE: 314 GPM
LIQUID CAPACITY: 560 GAL.
OIL CAPACITY: 285 GAL.
SAND CAPACITY: 162 GAL.
WEIGHT: 1,000 LBS.
COVER: CAST IRON

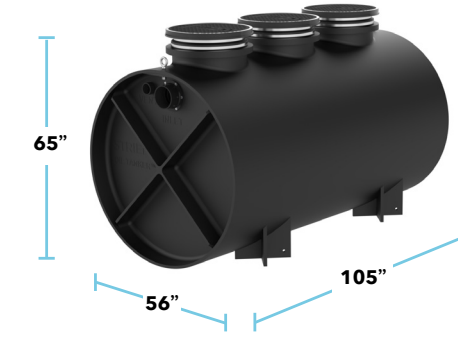

OT-750 24" CPRK HDK SS
CONNECTIONS: 4", 6", 8"
MAX FLOW RATE: 314 GPM
LIQUID CAPACITY: 750 GAL.
OIL CAPACITY: 323 GAL.
SAND CAPACITY: 295 GAL.
WEIGHT: 1,200 LBS.
COVER: CAST IRON

OPTIONS

Risers

See page 24 for more details

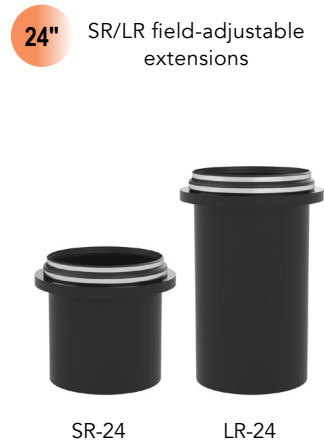

HDK High water table hold down kits

See page 25 for more details



SS Slick Stick™ oil level monitoring system

See page 9 for more details

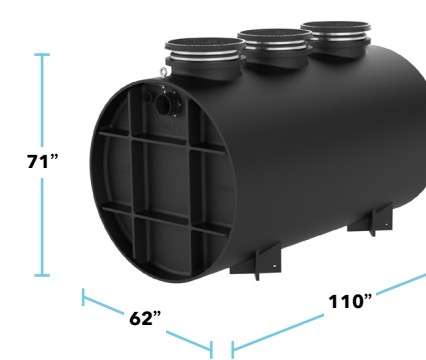

OT-1000 24" CPRK HDK SS
CONNECTIONS: 4", 6", 8"
MAX FLOW RATE: 314 GPM
LIQUID CAPACITY: 1,000 GAL.
OIL CAPACITY: 370 GAL.
SAND CAPACITY: 477 GAL.
WEIGHT: 1,450 LBS.
COVER: CAST IRON

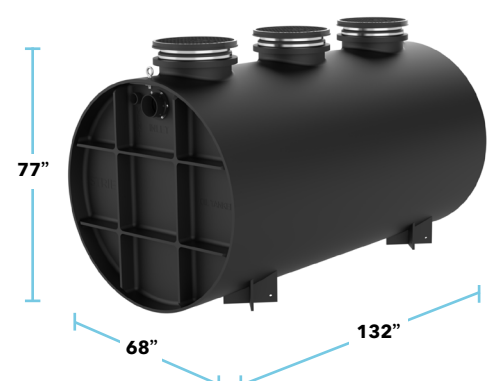

OT-1500 24" CPRK HDK SS
CONNECTIONS: 4", 6", 8"
MAX FLOW RATE: 314 GPM
LIQUID CAPACITY: 1,500 GAL.
OIL CAPACITY: 488 GAL.
SAND CAPACITY: 825 GAL.
WEIGHT: 1,600 LBS.
COVER: CAST IRON

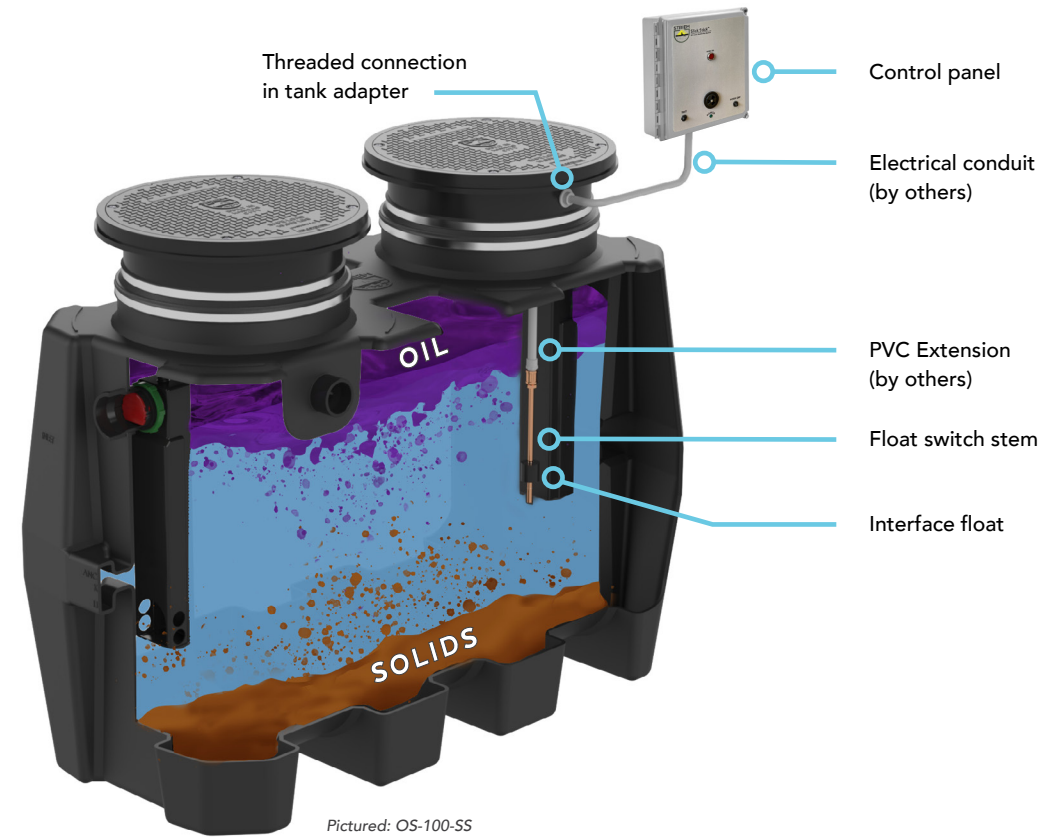

Control panel & float switch



Cover adapter with conduit connection & junction box

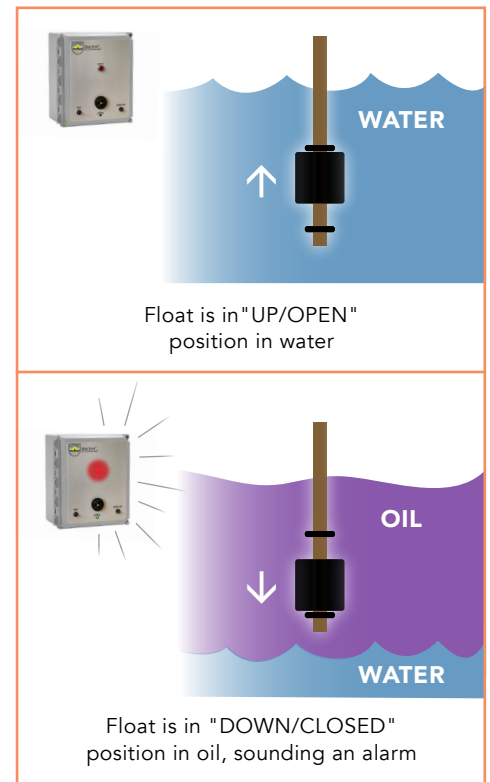
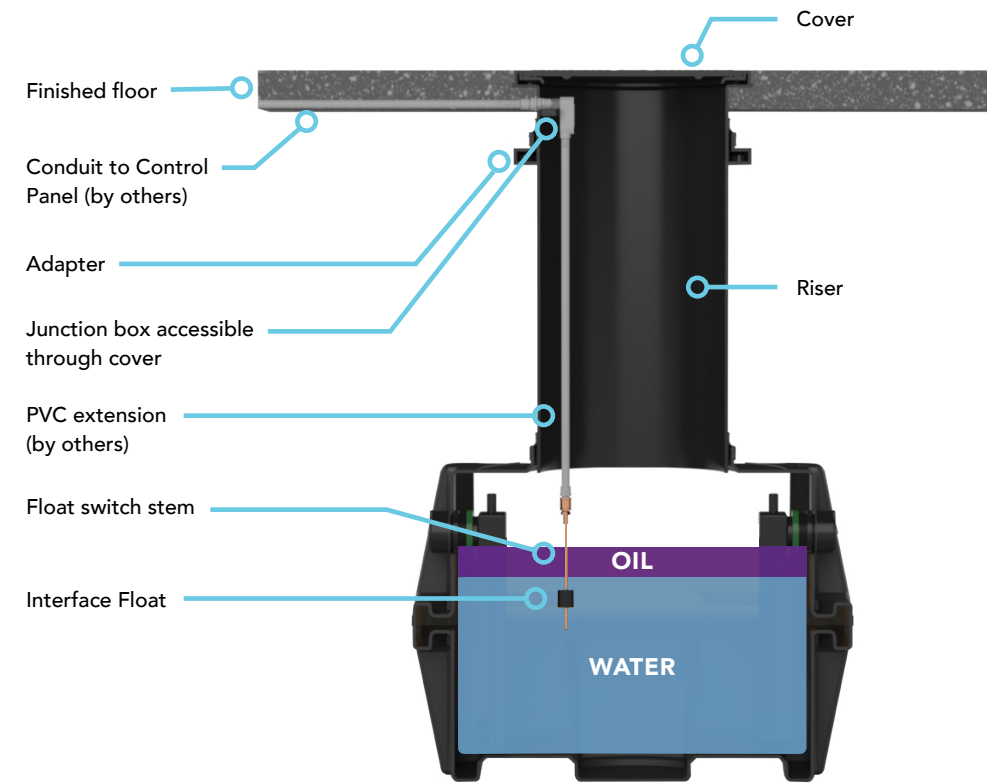

MODELS

- OS-50-SS
- OS-75-SS
- OS-100-SS
- OT-500-SS
- OT-750-SS
- OT-1000-SS
- OT-1500-SS

FEATURES

- UL listed
- Intrinsically safe
- Field-extendable interface float
- Ability to easily install with risers
- Audio and visual alarm
- BMS capability

SPECIFICATIONS

- Provides audio/visual alarm under high oil level condition.
- Single phase, 120 VAC, 60 hertz input power required.
- NEMA 4X enclosure.
- "HORN OFF" button silences audible alarm.
- "TEST" button tests system electronics.
- Locking clasp on door.
- Intrinsically safe sensor inputs.
- Interface float is buoyant in water, but sinks in the presence of hydrocarbons.

SOLIDS INTERCEPTORS



The Sidekick installed under a break room sink

POINT-OF-USE SIDE-ACCESS SOLIDS INTERCEPTOR

SIDEKICK™

NEW PRODUCT

UPC
List by IAPMO to IGC 167-2011ae2
Pat No. 10,786,761



LEARN MORE

Integral PVC socket connections for easy installation

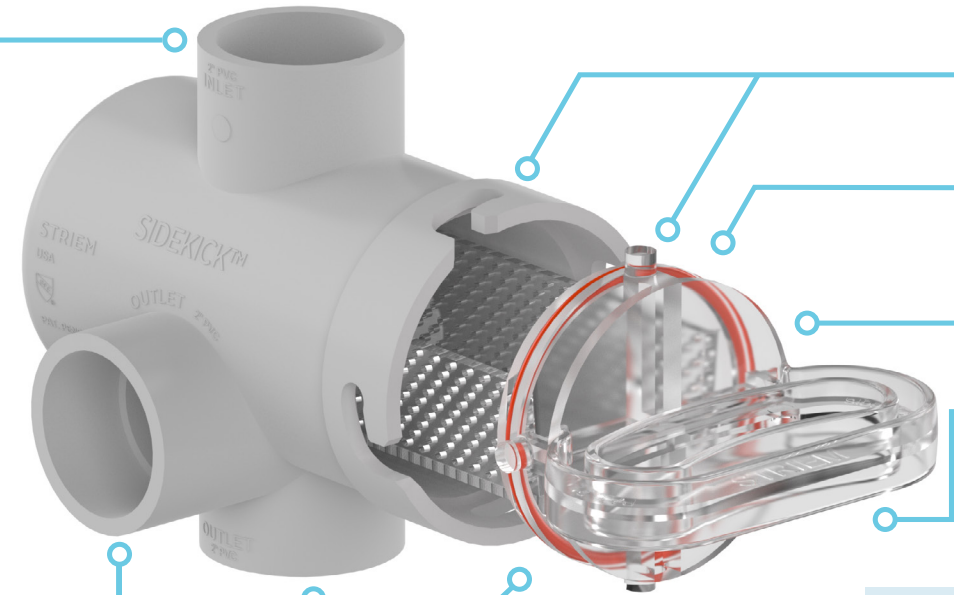

Geometric fit for a watertight seal

Side-access basket allows for maintenance in less than 30 seconds

Clear window to view solids accumulation

Handle is outside of solids collection area for clean maintenance

Three outlet options

- PARTS INCLUDED:
- 2 x 1 1/2" PVC adapter (2)
 - 2 x 1 1/2" NPS PVC adapter
 - 2" PVC plug (2)

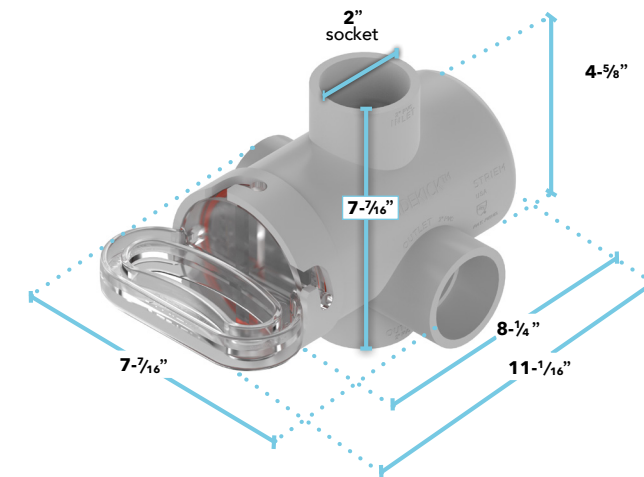

APPLICATIONS



LAUNDRY FACILITIES



COMMERCIAL KITCHENS



DOG WASH & PET KENNELS



ART ROOM SINKS



BARBER SHOPS & HAIR SALONS

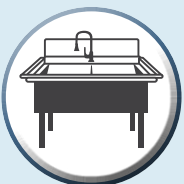

UTILITY SINKS

BASKET-STYLE SOLIDS INTERCEPTORS

Recommended for DIY maintenance

AARDVARK™ SERIES

UPC
List by IAPMO to IGC 167-2011ae2
Pat No. 10,786,761

CHECK OUT OUR ONLINE SIZING TOOL.
For laundry facilities

RFA DWG PDF CSI
AVAILABLE ONLINE FOR ALL PRODUCTS

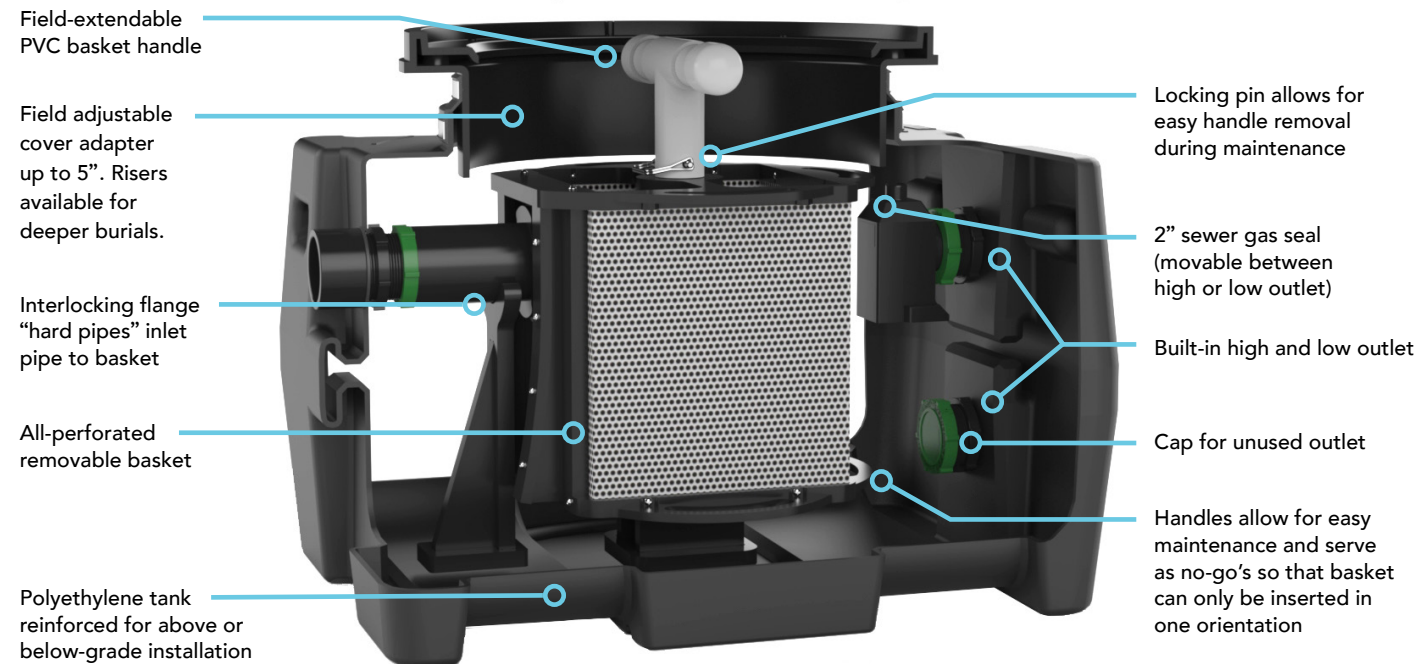

(AA-M shown)

OPTIONS

SR/LR field-adjustable extensions

See page 24 for more details

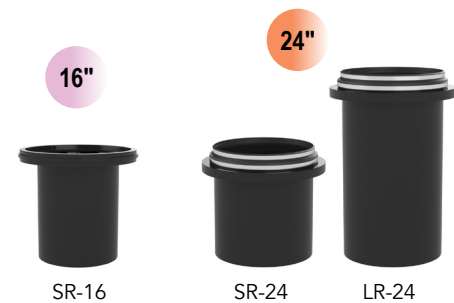

HDK High water hold down kits

See page 25 for more details



Covers

See page 26 for more details

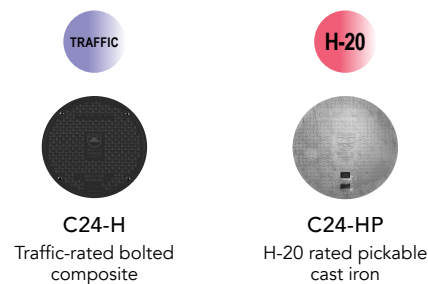

AA-S SMALL 16"

CONNECTIONS: 2", 3"
MAX FLOW RATE: 35 GPM
LIQUID CAPACITY: 16 GAL. (high outlet), 4 GAL. (low outlet)
SOLIDS CAPACITY: 2 GAL.
WEIGHT: 42 LBS.
COVER: PEDESTRIAN-RATED



AA-M MEDIUM 24"

CONNECTIONS: 3", 4"
MAX FLOW RATE: 50 GPM
LIQUID CAPACITY: 38 GAL. (high outlet), 12 GAL. (low outlet)
SOLIDS CAPACITY: 6 GAL.
WEIGHT: 83 LBS.
COVER: PEDESTRIAN-RATED



AA-L LARGE 24" HDK TRAFFIC H-20

CONNECTIONS: 3", 4"
MAX FLOW RATE: 75 GPM
LIQUID CAPACITY: 57 GAL. (high outlet), 14 GAL. (low outlet)
SOLIDS CAPACITY: 8 GAL.
WEIGHT: 105 LBS.
COVER: PEDESTRIAN-RATED



AA-XL EXTRA LARGE 24" HDK H-20

CONNECTIONS: 4"
MAX FLOW RATE: 100 GPM
LIQUID CAPACITY: 110 GAL. (high outlet), 30 GAL. (low outlet)
SOLIDS CAPACITY: 10 GAL.
WEIGHT: 143 LBS.
COVER: TRAFFIC-RATED

APPLICATIONS



LAUNDRY FACILITIES



COMMERCIAL KITCHENS



DOG WASH & PET KENNELS



ART ROOM SINKS



BARBER SHOPS & HAIR SALONS



FOOD PROCESSING

**SCREEN-STYLE
SOLIDS INTERCEPTORS**

Recommended for professional pumper maintenance

PROSPECTOR™ SERIES



PS-15-S 16"
CONNECTIONS: 2", 3" **SOLIDS CAPACITY:** 7 GAL.
MAX FLOW RATE: 15 GPM **WEIGHT:** 30 LBS.
LIQUID CAPACITY: 15 GAL. **COVER:** PEDESTRIAN-RATED

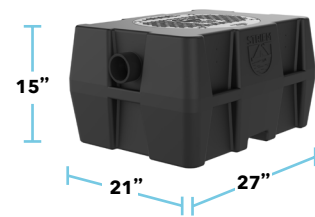

PS-25-S 16"
CONNECTIONS: 2", 3" **SOLIDS CAPACITY:** 10 GAL.
MAX FLOW RATE: 25 GPM **WEIGHT:** 35 LBS.
LIQUID CAPACITY: 21 GAL. **COVER:** PEDESTRIAN-RATED

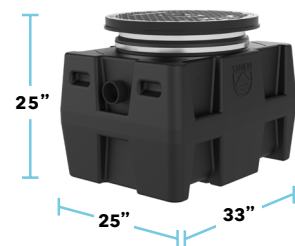

PS-35-S 24"
CONNECTIONS: 2", 3", 4" **SOLIDS CAPACITY:** 19 GAL.
MAX FLOW RATE: 35 GPM **WEIGHT:** 83 LBS.
LIQUID CAPACITY: 38 GAL. **COVER:** PEDESTRIAN-RATED



PS-50-S 24" HDK TRAFFIC H-20
CONNECTIONS: 2", 3", 4" **SOLIDS CAPACITY:** 29 GAL.
MAX FLOW RATE: 50 GPM **WEIGHT:** 100 LBS.
LIQUID CAPACITY: 57 GAL. **COVER:** PEDESTRIAN-RATED



PS-125-S 24" HDK H-20
CONNECTIONS: 4", 6" **SOLIDS CAPACITY:** 55 GAL.
MAX FLOW RATE: 126 GPM **WEIGHT:** 140 LBS.
LIQUID CAPACITY: 110 GAL. **COVER:** TRAFFIC-RATED

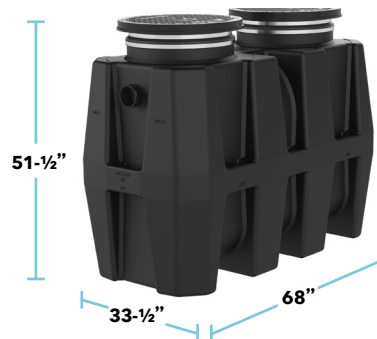

PS-275-S 24" HDK H-20
CONNECTIONS: 4", 6" **SOLIDS CAPACITY:** 210 GAL.
MAX FLOW RATE: 126 GPM **WEIGHT:** 270 LBS.
LIQUID CAPACITY: 250 GAL. **COVER:** TRAFFIC-RATED

**SAND
INTERCEPTORS**

SETTLER™ SERIES



CB-50-S 24" HDK H-20
CONNECTIONS: 2", 3", 4" **SOLIDS CAPACITY:** 25 GAL.
MAX FLOW RATE: 50 GPM **WEIGHT:** 92 LBS.
LIQUID CAPACITY: 57 GAL. **COVER:** TRAFFIC-RATED



CB-50-G 24" HDK
CONNECTIONS: 3", 4" **SOLIDS CAPACITY:** 25 GAL.
MAX FLOW RATE: 50 GPM **WEIGHT:** 187 LBS.
LIQUID CAPACITY: 57 GAL. **COVER:** CAST IRON GRATE



CB-125-S 24" HDK H-20 CPRK
CONNECTIONS: 4" **SOLIDS CAPACITY:** 70 GAL.
MAX FLOW RATE: 126 GPM **WEIGHT:** 130 LBS.
LIQUID CAPACITY: 110 GAL. **COVER:** TRAFFIC-RATED



CB-125-G 24" HDK
CONNECTIONS: 4", 6" **SOLIDS CAPACITY:** 70 GAL.
MAX FLOW RATE: 126 GPM **WEIGHT:** 213 LBS.
LIQUID CAPACITY: 110 GAL. **COVER:** CAST IRON GRATE



CB-275-S 24" HDK H-20 CPRK
CONNECTIONS: 4", 6" **SOLIDS CAPACITY:** 200 GAL.
MAX FLOW RATE: 126 GPM **WEIGHT:** 230 LBS.
LIQUID CAPACITY: 250 GAL. **COVER:** TRAFFIC-RATED

OPTIONS

SR/LR field-adjustable extensions
 See page 24 for more details

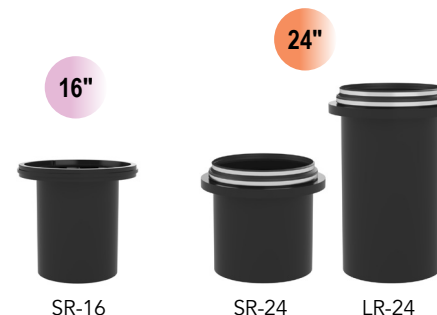

HDK High water hold down kits
 See page 25 for more details



CPRK Corrugated Pipe Riser Kit (CPRK)
 See page 24 for more details



Covers
 See page 26 for more details

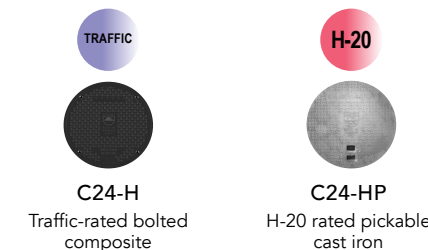

CHEMICAL WASTE TANKS



Striemsmiths Scott and Darrell building a neutralization tank

UNDER COUNTER NEUTRALIZATION TANKS

LAB RAT™ SERIES

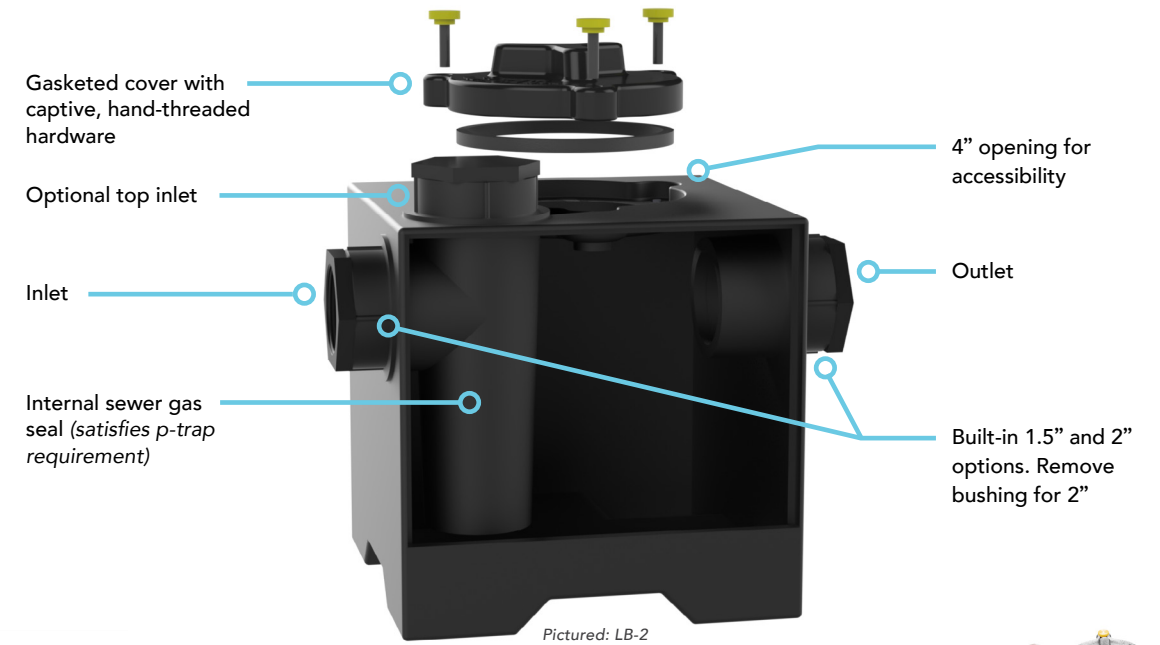

Pictured: LB-2

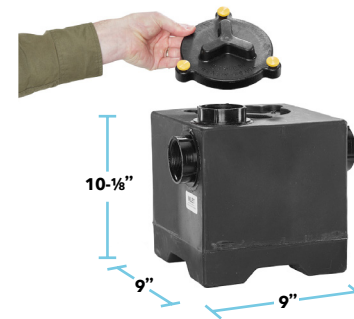

LB-2

CONNECTIONS: 1.5", 2" **LIMESTONE LOAD:** 25 LBS.
LIQUID CAPACITY: 2 GAL. **WEIGHT:** 6 LBS.
of LAB SINKS: 1

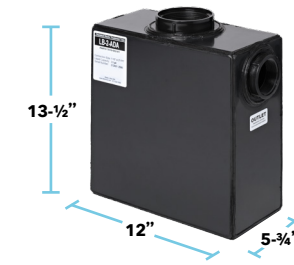

LB-2-ADA

CONNECTIONS: 1.5", 2" **LIMESTONE LOAD:** 25 LBS.
LIQUID CAPACITY: 2 GAL. **WEIGHT:** 10 LBS.
of LAB SINKS: 1



LB-5

CONNECTIONS: 1.5", 2" **LIMESTONE LOAD:** 50 LBS.
LIQUID CAPACITY: 5 GAL. **WEIGHT:** 11 LBS.
of LAB SINKS: 2

APPLICATION LAYOUTS

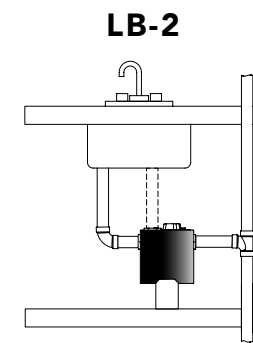

LAB SINK

4" PVC pipe for support cut to size (by others)

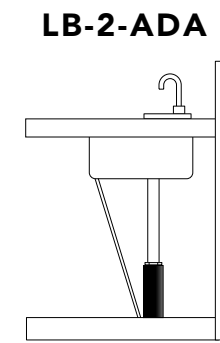

LAB SINK

**CENTRALIZED
NEUTRALIZATION TANKS**

LAB BASIN™ SERIES



LB-15 16" LS CC-1
CONNECTIONS: 2", 3" **LIMESTONE LOAD:** 200 LBS.
LIQUID CAPACITY: 15 GAL. **WEIGHT:** 28 LBS.
OF LAB SINKS: 4 **COVER:** PEDESTRIAN-RATED

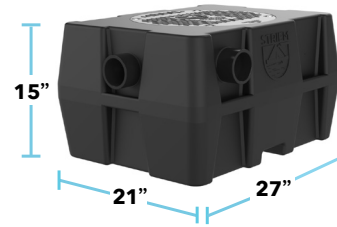

LB-25 16" LS CC-1
CONNECTIONS: 2", 3" **LIMESTONE LOAD:** 300 LBS.
LIQUID CAPACITY: 21 GAL. **WEIGHT:** 31 LBS.
OF LAB SINKS: 6 **COVER:** PEDESTRIAN-RATED

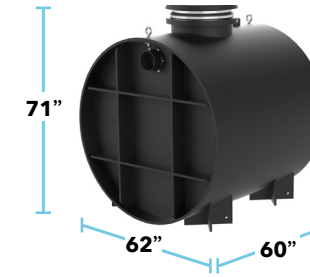

LB-500 24" LS HDK CC-1 CPRK
CONNECTIONS: 4", 6", 8" **LIMESTONE LOAD:** 6,500 LBS.
LIQUID CAPACITY: 500 GAL. **WEIGHT:** 750 LBS.
OF LAB SINKS: 150 **COVER:** TRAFFIC-RATED

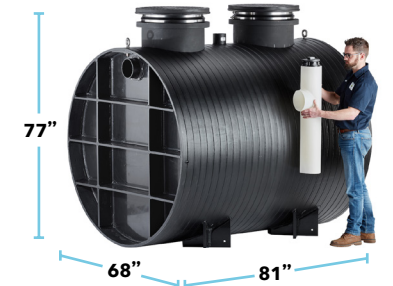

LB-750 24" LS HDK CC-1 CPRK
CONNECTIONS: 4", 6", 8" **LIMESTONE LOAD:** 9,800 LBS.
LIQUID CAPACITY: 750 GAL. **WEIGHT:** 1,090 LBS.
OF LAB SINKS: 215 **COVER:** TRAFFIC-RATED



LB-35 24" LS CC-1
CONNECTIONS: 2", 3", 4" **LIMESTONE LOAD:** 450 LBS.
LIQUID CAPACITY: 38 GAL. **WEIGHT:** 77 LBS.
OF LAB SINKS: 9 **COVER:** PEDESTRIAN-RATED



LB-50 24" LS TRAFFIC HDK CC-1
CONNECTIONS: 2", 3", 4" **LIMESTONE LOAD:** 650 LBS.
LIQUID CAPACITY: 57 GAL. **WEIGHT:** 92 LBS.
OF LAB SINKS: 15 **COVER:** PEDESTRIAN-RATED

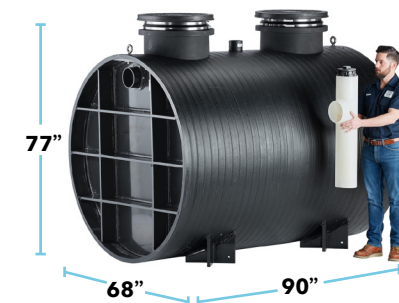

LB-1000 24" LS HDK CC-1 CPRK
CONNECTIONS: 4", 6", 8" **LIMESTONE LOAD:** 13,000 LBS.
LIQUID CAPACITY: 1,000 GAL. **WEIGHT:** 1,215 LBS.
OF LAB SINKS: 260 **COVER:** TRAFFIC-RATED

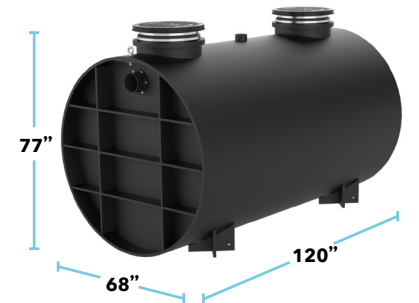

LB-1500 24" LS HDK CC-1 CPRK
CONNECTIONS: 4", 6", 8" **LIMESTONE LOAD:** 19,500 LBS.
LIQUID CAPACITY: 1500 GAL. **WEIGHT:** 1,350 LBS.
OF LAB SINKS: 375 **COVER:** TRAFFIC-RATED



LB-125 24" LS HDK CC-1 CPRK
CONNECTIONS: 3", 4", 6" **LIMESTONE LOAD:** 1,550 LBS.
LIQUID CAPACITY: 110 GAL. **WEIGHT:** 130 LBS.
OF LAB SINKS: 35 **COVER:** TRAFFIC-RATED



LB-275 24" LS HDK CC-1 CPRK
CONNECTIONS: 3", 4", 6" **LIMESTONE LOAD:** 3,150 LBS.
LIQUID CAPACITY: 250 GAL. **WEIGHT:** 230 LBS.
OF LAB SINKS: 75 **COVER:** TRAFFIC-RATED

OPTIONS

SR/LR field-adjustable extensions
 See page 24 for more details



Covers
 See page 26 for more details

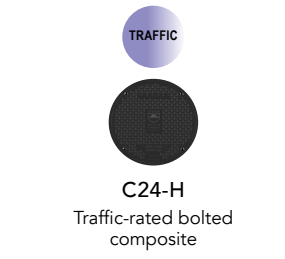

CPRK Corrugated Pipe Riser Kit (CPRK)
 See page 24 for more details



HDK High water hold down kits
 See page 25 for more details



CC-1 Command Center™ pH Monitoring System
 See page 21 for more details





Clear front panel

Touchscreen interface

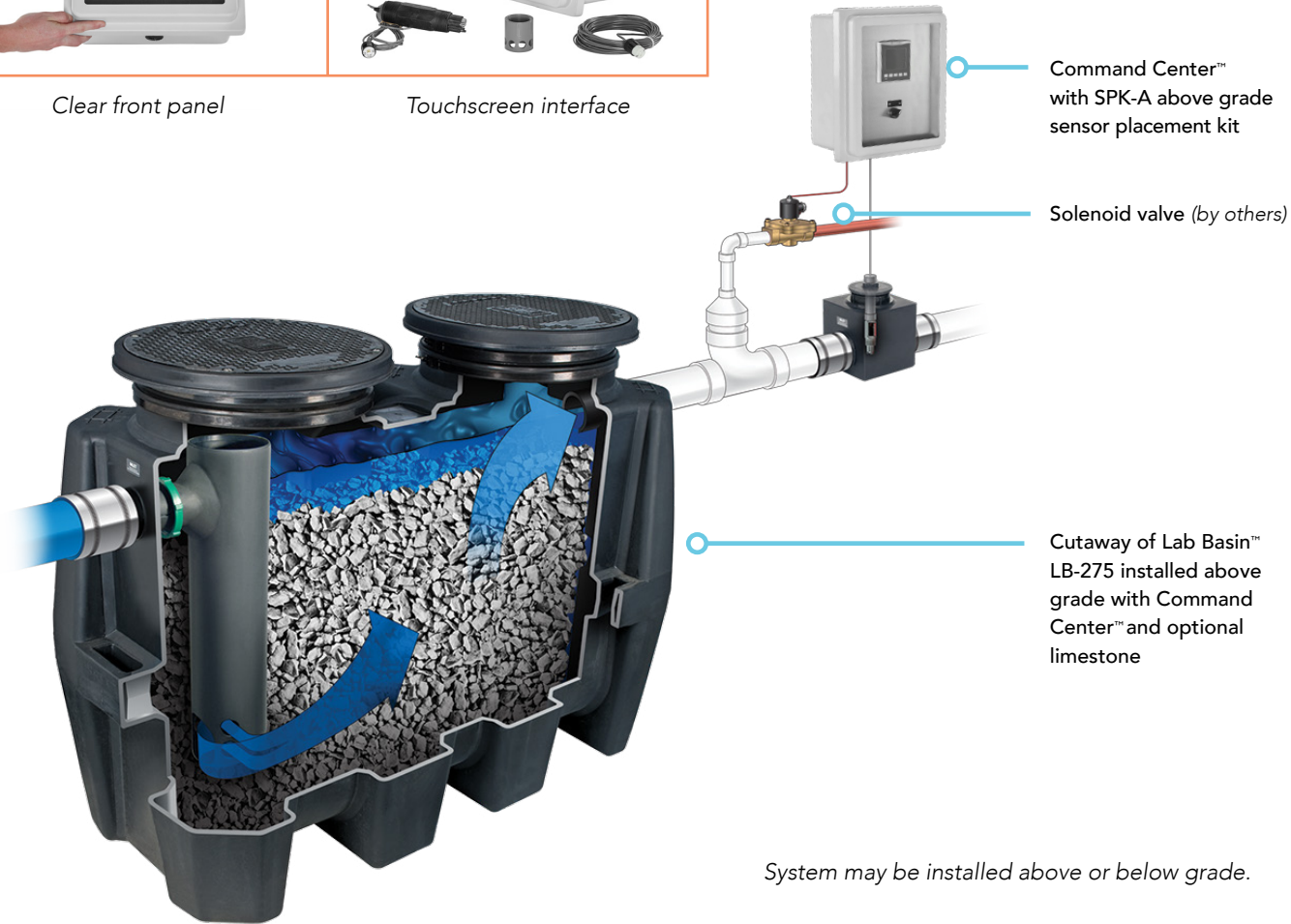

System may be installed above or below grade.

SPECIFICATIONS

- BMS Capability via ethernet connection
- Pre-programmed audio/visual alarm set points
- 3.5" color touchscreen display
- Storage: Includes (2), 1-year micro SD cards
- Pre-programmed with digital output to power solenoid valve for fresh water to flush if PH approaches high/low limits
- Nema 4x lockable weather proof enclosure -32°F to 122°F
- 120V AC power supply required



BB-275 24" HDK CPRK
CONNECTIONS: 2", 3", 4", 6"
LIQUID CAPACITY: 250 GAL.
WEIGHT: 230 LBS.
COVER: TRAFFIC-RATED

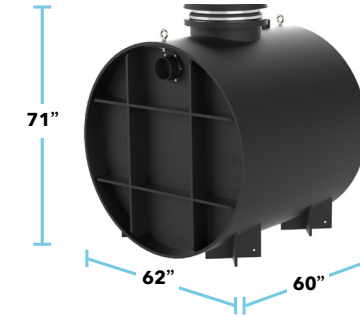

BB-500 24" HDK CPRK
CONNECTIONS: 2", 3", 4", 6"
LIQUID CAPACITY: 500 GAL.
WEIGHT: 750 LBS.
COVER: TRAFFIC-RATED

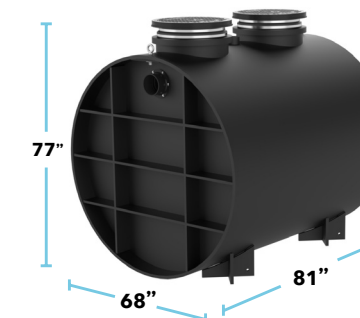

BB-750 24" HDK CPRK
CONNECTIONS: 2", 3", 4", 6"
LIQUID CAPACITY: 750 GAL.
WEIGHT: 1,090 LBS.
COVER: TRAFFIC-RATED

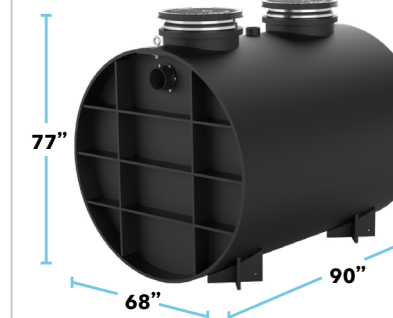

BB-1000 24" HDK CPRK
CONNECTIONS: 2", 3", 4", 6"
LIQUID CAPACITY: 1,000 GAL.
WEIGHT: 1,215 LBS.
COVER: TRAFFIC-RATED

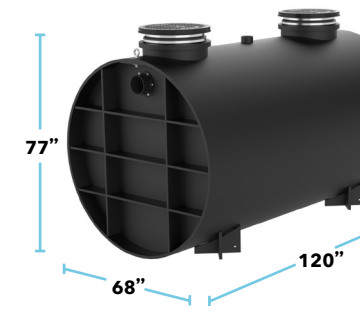

BB-1500 24" HDK CPRK
CONNECTIONS: 2", 3", 4", 6"
LIQUID CAPACITY: 1,500 GAL.
WEIGHT: 1,350 LBS.
COVER: TRAFFIC-RATED

MONITORING PACKAGES



LOW OUTLET VALVE PACKAGES AVAILABLE
 See product specifications at striemco.com.

Striem recommends the following steps for sizing a decontamination tank:

$$\left[\begin{array}{l} \text{Number of} \\ \text{Fixtures} \\ \text{(showers or} \\ \text{eyewash stations)} \end{array} \right] \times \left[\begin{array}{l} \text{Supply Line} \\ \text{Flow Rate of} \\ \text{Each Fixture} \end{array} \right] \times \left[\begin{array}{l} \text{Rinse Time} \\ \text{(15-20 minutes} \\ \text{typical)} \end{array} \right] = \text{SIZE OF} \\ \text{TANK IN} \\ \text{GALLONS}$$

Sizing Sample:

1. A hospital with two emergency showers, each with a 3/4" supply line carrying a flow rate of 9.96 GPM. 2 fixtures x 9.96 GPM = 19.92 GPM
2. 19.92 GPM x 15 minutes = 298.8 gallons
3. Select Bio Basin™ model BB-500 (584 liquid holding gallons)

OPTIONS

24" SR/LR field-adjustable extensions
 See page 24 for more details



HDK High water hold down kits
 See page 25 for more details



CPRK Corrugated Pipe Riser Kit (CPRK)
 See page 24 for more details



INSPECTOR™

INSPECTOR-4

4" connections



INSPECTOR-6

6" connections



Narrowed inlet flow path for easy sampling

1/2" offset to create sample waterfall.



SPECIFICATIONS

- Unit supplied with built-in adapter for up to 2-1/2" of adjustability.
- Additional riser(s) available for deeper burial depth.
- Polyethylene construction
- Lightweight and easy to install
- Maximum operating temperature 140° F.
- Highway rated (16,000 lb. load) bolted, gas/water tight composite cover.

FIELD-ADJUSTABLE RISERS

SEE PRODUCT SPECIFICATIONS FOR RISER OPTIONS

SR-16

For use with tanks with 16" cover



SR-24

SHORT RISER

For use with tanks with 24" cover



LR-24

LONG RISER

For use with tanks with 24" cover



Tilt adapter up to 6.5° in all directions.



CPRK Corrugated Pipe Riser Kit

Uses 18" Inner Diameter ADS N-12 Dual Wall HDPE Pipe (by others).

More cost-effective for deeper burials and/or on tanks with multiple manways.



HIGH WATER ANCHOR KITS

HDK-2



Compatible with:
 OS-50, OS-75, OS-100, OS-500,
 OS-50-SS, OS-75-SS, OS-100-SS
 AA-L, AA-XL-4, AA-XL-6
 PS-50-S, PS-125-S, PS-275-S
 CB-50-S, CB-125-S, CB-275-S
 CB-50-G, CB-125-G
 SI-UPC-1016
 LB-50, LB-125, LB-275
 BB-275
 CB-50-SFL, CB-125-SFL, CB-275-SFL
 FLI-125, FLI-275
 OCT-50, OCT-125, OCT-275
 OS-100-OMAHA

HDK-500



Compatible with:
 OT-500, OT-500-SS, OS-500-WSSC

HDK-750



Compatible with:
 OT-750, OT-750-SS

HDK-1000



Compatible with:
 OT-1000, OT-1000-SS

HDK-1500



Compatible with:
 OT-1500, OT-1500-SS, OS-1600-WSSC

HDK-CWT-500



Compatible with:
 BB-500, LB-500

HDK-1



Compatible with:
 OS-750, OS-1000, OS-1500
 LB-750, LB-1000, LB-1500
 BB-750, BB-1000, BB-1500

COVERS



C16-M

LOCATION: INDOOR
DIAMETER: 16"
TYPE: BOLTED POLYPRO
LOAD RATING: 2,500 LBS.



C24-M

LOCATION: INDOOR
DIAMETER: 24"
TYPE: BOLTED COMPOSITE
LOAD RATING: 2,000 LBS.



C24-H

LOCATION: INDOOR / OUTDOOR
DIAMETER: 24"
TYPE: BOLTED COMPOSITE
LOAD RATING: 16,000 LBS.

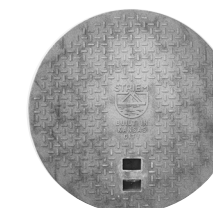

C24-HP

LOCATION: OUTDOOR
DIAMETER: 24"
TYPE: PICKABLE CAST IRON
LOAD RATING: 16,000 LBS. H-2O RATED

NOTES





 913-222-1500

 HELP@STRIEMCO.COM

 STRIEMCO.COM