

SPECIFICATIONS

1. 4" Plain End inlet/outlet, 3" Plain End vents.
2. Max flow rate: 100 GPM
3. Capacities: Liquid: 250 gal. (33.4 cu. ft.); Oil: 144 gal.; Sand: 95 gal.
4. Unit weight with composite cover: 230 lbs.; with cast iron: 346 lbs.
5. Maximum operating temperature 140 °F continuous.
6. Highway rated covers: 16,000 lb. capacity.

NOTES

1. Snap-in Flow control (ships with unit).
2. Seamless medium density polyethylene tank.
3. Unit supplied with built-in adapter for up to 6" of adjustability. Additional riser(s) available for deeper burial depth.
4. Cover placement allows full access to tank for proper maintenance.
5. Narrow footprint allows clearance through doorways and down stairs.
6. Engineered inlet and outlet diffusers are removable to inspect/clean piping.
7. For on the-floor or buried applications.

DIFFUSION FLOW TECHNOLOGY

The inlet diffuser splits influent into three paths, creating laminar flow and utilizing the entire liquid volume of the tank for efficient oil separation. The calibrated openings greatly reduce influent turbulence. The influent enters the main chamber without disturbing the existing oil or sand layers. The bottom of the outlet diffuser allows only effluent that is free of oil to exit the tank.

ENGINEER SPECIFICATION GUIDE

Striem Oil Reserve™ oil/sand separator model OS-100 shall be lifetime guaranteed and made in USA of seamless, rotationally-molded polyethylene. Separator shall be furnished for above or below grade installation, with field adjustable riser system, snap-in flow control and (2) vent connections. Separator flow rate shall be 100 GPM. Separator oil capacity shall be 144 gallons. Sand capacity shall be 95 gallons. Covers shall provide water/gas-tight seal and have a maximum 16,000 lbs load capacity.

THIRD PARTY STRUCTURAL ANALYSIS

The OS-100 has been structurally analyzed in accordance with the requirements of IBC 2012 and ASCE/SEI 7 for direct burial. The maximum burial depth and backfill material are specified in our installation instructions. The structural design has been reviewed and sealed by a professional engineer registered in the state of California. A sealed structural analysis report is available upon request.

OPTIONS

- 4M** - 4" Male Thread Inlet / Outlet
- 6P** - 6" Plain End SCH.40 Inlet / Outlet
- 6M** - 6" Male Thread Inlet / Outlet
- C24-HP (2)** - H20 Rated Pickable Cast Iron Cover
- CC24 (2)** - Integral Membrane Clamping Collar Kit
- CS3** - Clean Sweep Coalescing Media (single)
- CS6** - Clean Sweep Coalescing Media (double)
- AK1** - High Water Anchor Kit

TeleGlide RISER OPTIONS

- SR24 (2)** - >6"-24"
- LR24 (2)** - >24"-39"
- SR24 (4)** - >39"-43"
- SR24 (2) + LR24 (2)** - >43"-58"
- LR24 (4)** - >58"-72"

PROPRIETARY AND CONFIDENTIAL

THE INFORMATION CONTAINED IN THIS DRAWING IS THE SOLE PROPERTY OF STRIEM, LLC. ANY REPRODUCTION IN PART OR AS A WHOLE WITHOUT THE WRITTEN PERMISSION OF STRIEM, LLC. IS PROHIBITED.

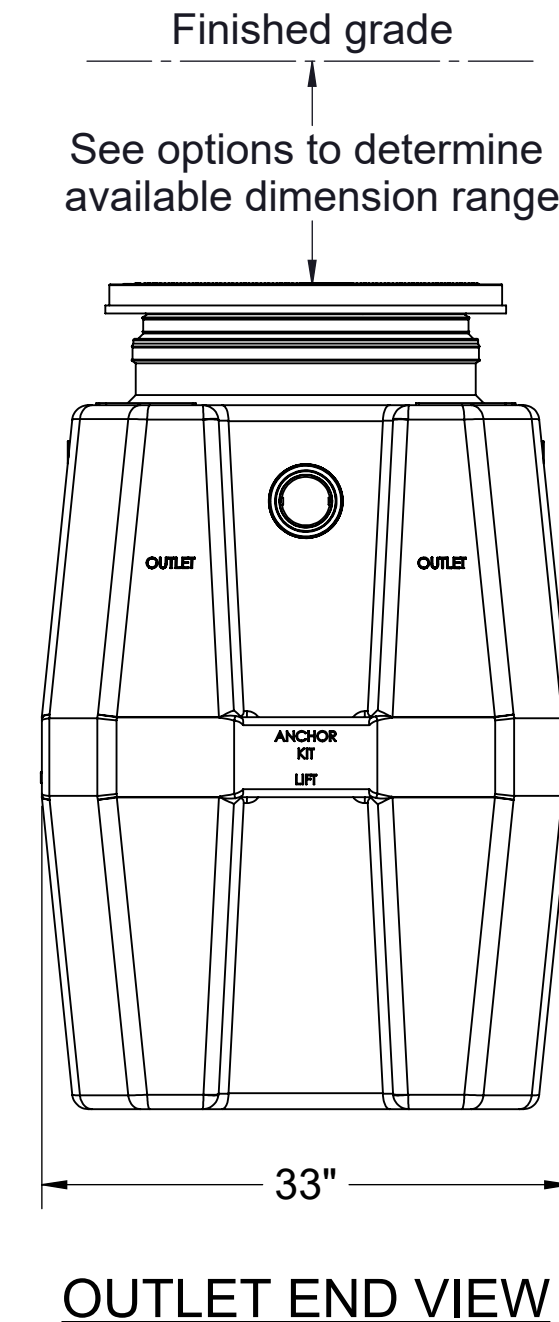
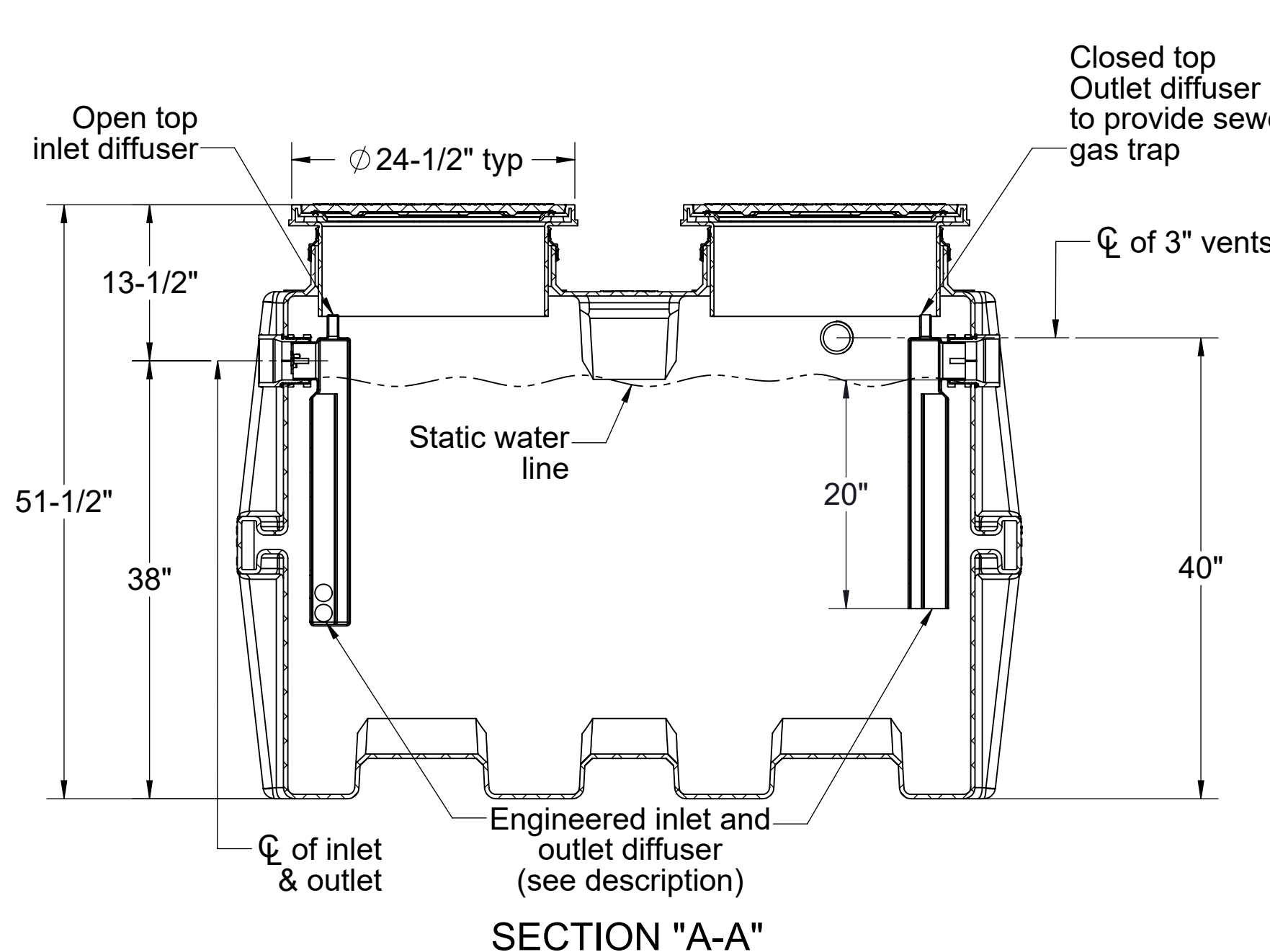
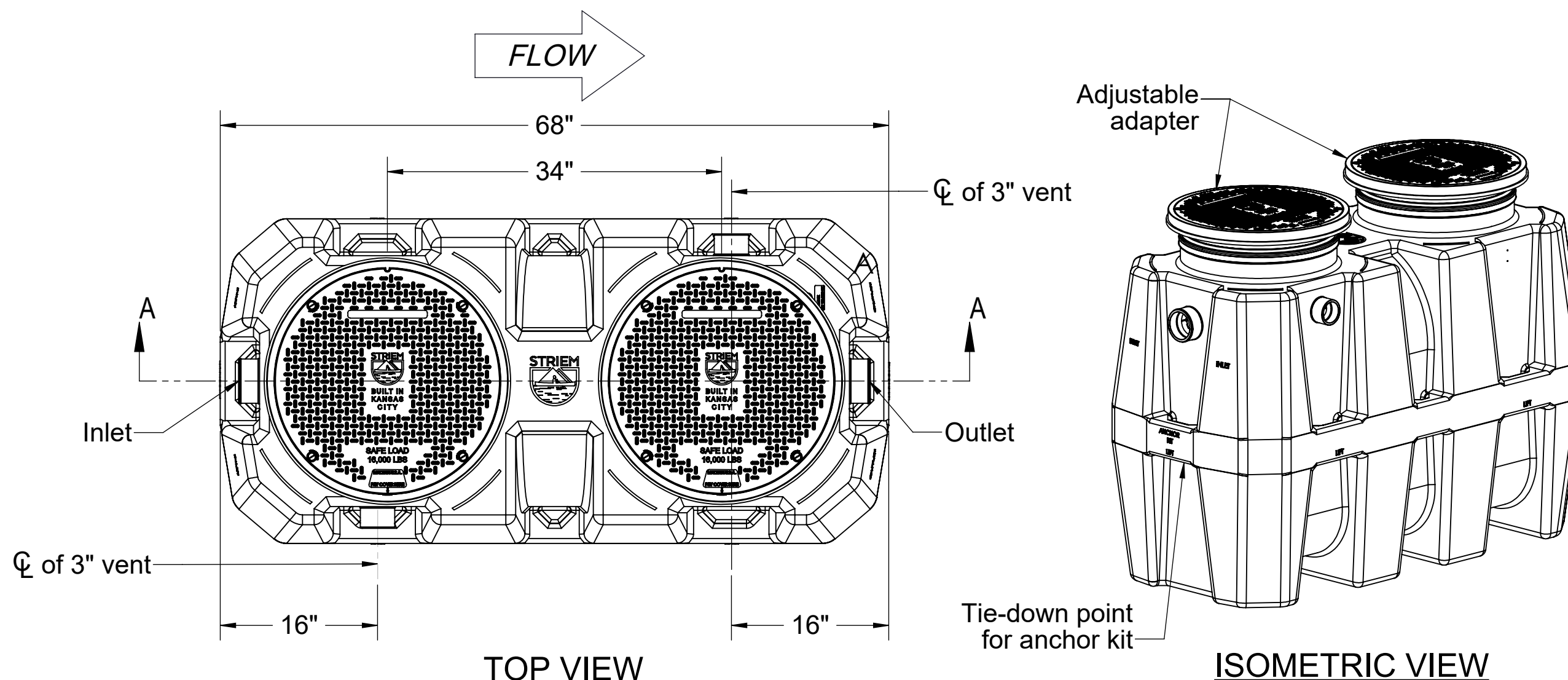

MODEL NUMBER:	OS-100
DESCRIPTION:	100 GPM POLYETHYLENE OIL/SAND SEPARATOR
DWG BY:	MJ
DATE:	04/29/2020
REV:	0
ECO:	

SPECIFICATION SHEET

Striem
 3100 Brinkerhoff
 Kansas City, KS 66115
 Tel: 913-222-1500
 Fax: 913-291-0457
 www.striemco.com

Made in the U.S.A

