

SPECIFICATIONS

1. Max flow rate: 314 GPM
2. Liquid capacity: 1000 Gallons (133.7 cu. ft.)
3. Oil capacity: 451 Gallons
4. Solids/sediment capacity: 347 Gallons
5. Unit weight w/std. covers: 1400 lbs.
6. Highway traffic load rated, bolted, gas/water tight composite covers. (16,000 lbs)
7. Maximum operating temperature 140°F continuous.

NOTES

1. 1" thick high density polyethylene walls.
2. Unit supplied with built-in adapter(s) for up to 6" of adjustability. Additional riser(s) available for deeper burial depth.
3. For buried applications.
4. Lifting lug set included for easy install.

ENGINEER SPECIFICATION GUIDE

Striem oil separator model OS-1000 shall be lifetime guaranteed and made in USA of High Density Polyethylene with minimum 1" uniform wall thickness. Separator shall be furnished for below grade installation with field adjustable riser system. Separator flow rate shall be 314 GPM. Separator oil capacity shall be 451 gallons. Sand capacity shall be 347 gallons. Cover shall provide water/gas-tight seal and have a maximum 16,000 lbs load capacity.

THIRD PARTY STRUCTURAL ANALYSIS

The OS-1000 has been structurally analyzed in accordance with the requirements of IBC 2012 and ASCE/SEI 7 for direct burial. The maximum burial depth and backfill material are specified in our installation instructions. The structural design has been reviewed and sealed by a professional engineer registered in the state of California. A sealed structural analysis report is available upon request.

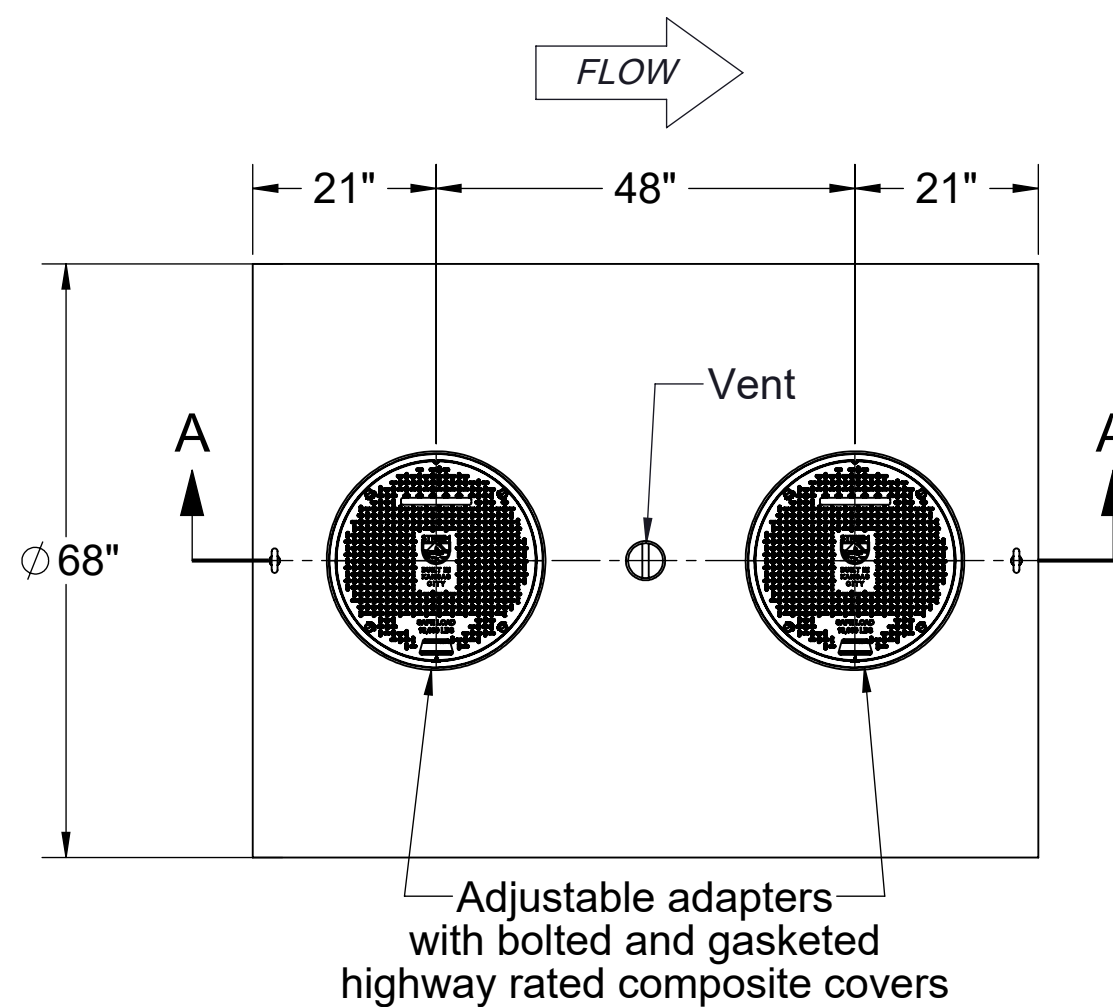
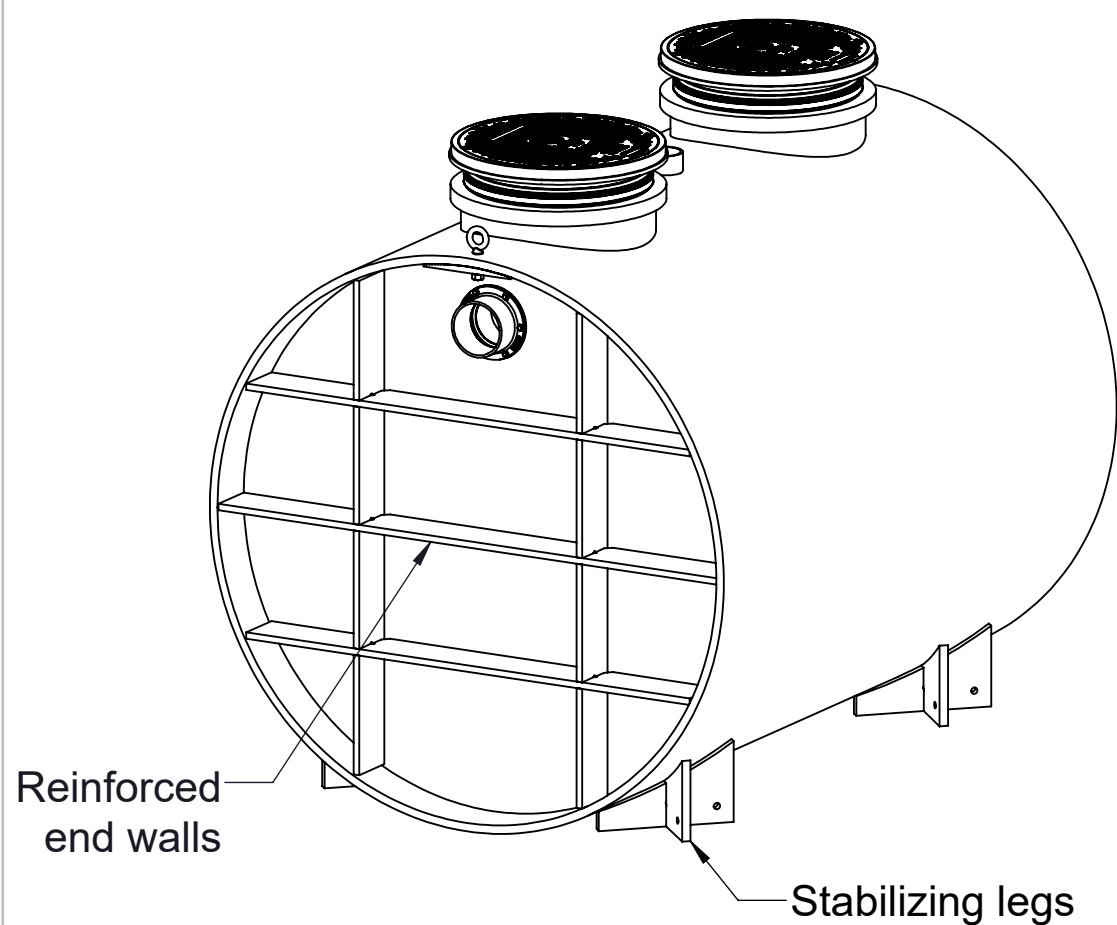

TOP VIEW

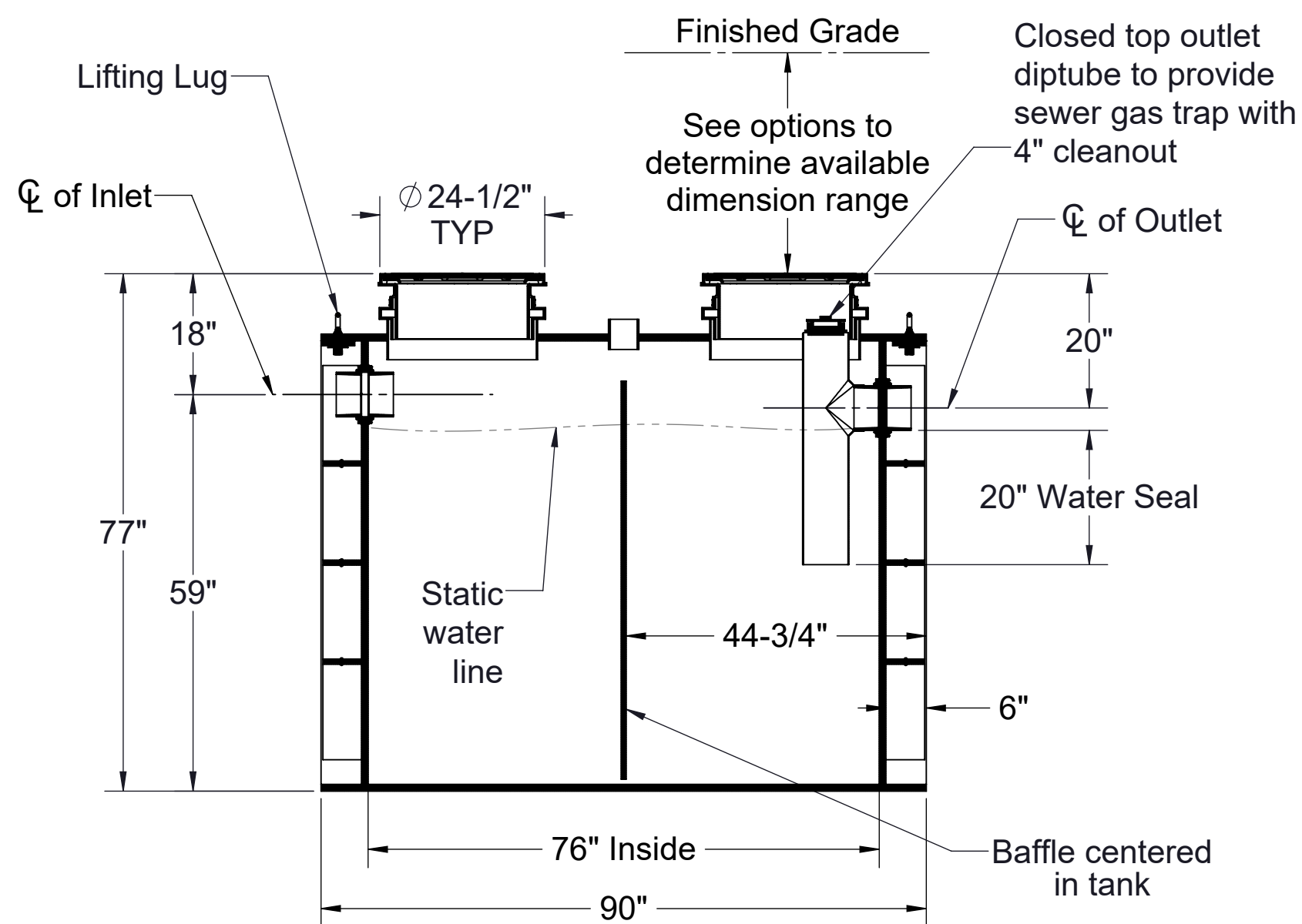

SECTION A-A

Directions: Complete steps 1-3 and submit signed with purchase order.

1. Choose Connection Types.

- | | |
|--|---|
| Inlet / Outlet | Size |
| <input type="checkbox"/> Plain End | <input type="checkbox"/> 4" |
| <input type="checkbox"/> Female Thread | <input type="checkbox"/> 6" (Female Thread Not Available) |
| <input type="checkbox"/> Flanged | <input type="checkbox"/> 8" (Only Plain End Available) |
| Vent | Size |
| <input type="checkbox"/> Plain End | <input type="checkbox"/> 2" |
| <input type="checkbox"/> Female Thread | <input type="checkbox"/> 3" |
| <input type="checkbox"/> Flanged | <input type="checkbox"/> 4" |

2. TeleGlide Riser Options.

- SR24 (2) - >6"-24"
- LR24 (2) - >24"-39"
- SR24 (4) - >39"-43"
- SR24 (2) + LR24 (2) - >43"-58"
- LR24 (4) - >58"-72"

3. Choose Additional Options.

- C24-HP (2) - H2O Rated Pickable Cast Iron Covers
- CS3 - Clean Sweep Coalescing Media (single)
- CS6 - Clean Sweep Coalescing Media (double)
- HDK-1 - High Water Table Hold Down Kit
- SS - Slick Stick™ oil level monitoring system

*Monitoring system will raise covers by 2-1/2". Not available with CS6. For more information, see OS-1000-SS specification package.

Signature of Approval: _____
 Company: _____
 Date of Approval: _____
 Specifying Engineer: _____
 Engineering Firm: _____

PO IS NON-CANCELABLE
 ORDER IS NON-RETURNABLE

MODEL NUMBER:	OS-1000
DESCRIPTION:	POLYETHYLENE OIL SEPARATOR 314 GPM 1000 GALLON CAPACITY
DWG BY:	MJ
DATE:	07/25/2019
REV:	0
ECO:	

SPECIFICATION SHEET

Striem
 3100 Brinkerhoff
 Kansas City, KS 66115
 Tel: 913-222-1500
 Fax: 913-291-0457
 www.striemco.com

Made in the U.S.A



PROPRIETARY AND CONFIDENTIAL
 THE INFORMATION CONTAINED IN THIS DRAWING IS THE SOLE PROPERTY OF STRIEM, LLC. ANY REPRODUCTION IN PART OR AS A WHOLE WITHOUT THE WRITTEN PERMISSION OF STRIEM, LLC. IS PROHIBITED.