

SPECIFICATIONS

1. 4" Plain End inlet/outlet, 3" Plain End vents.
2. Capacities: Liquid: 262 gallons (35 cu.ft.); Sand: 111 gallons.
3. Flammable liquid capacity: 129 gallons.
4. Unit weight with composite cover: 230 lbs.;
With cast iron covers: 346 lbs.
5. Maximum operating temperature 140°F continuous.
6. Highway rated covers: 16,000 lb. capacity.

NOTES

1. Seamless polyethylene tank.
2. Unit supplied with built-in adapter for up to 6" of adjustability. Additional riser(s) available for deeper burial depth.
3. Cover placement allows full access to tank for proper maintenance.
4. Narrow footprint allows clearance through doorways and down stairs.
5. Outlet diptube is removable to inspect/clean piping.
6. For on-the-floor or buried applications.

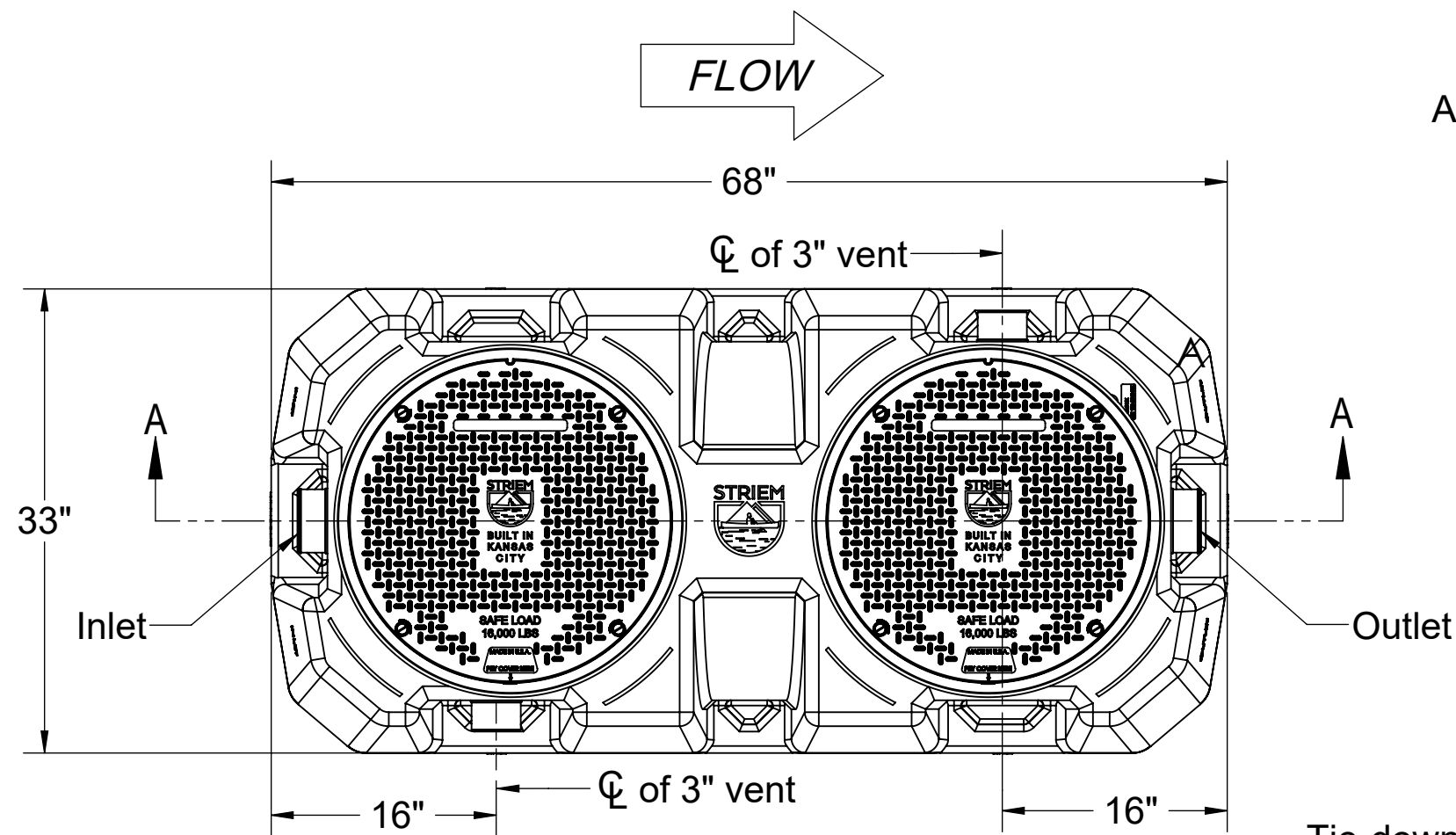

TOP VIEW

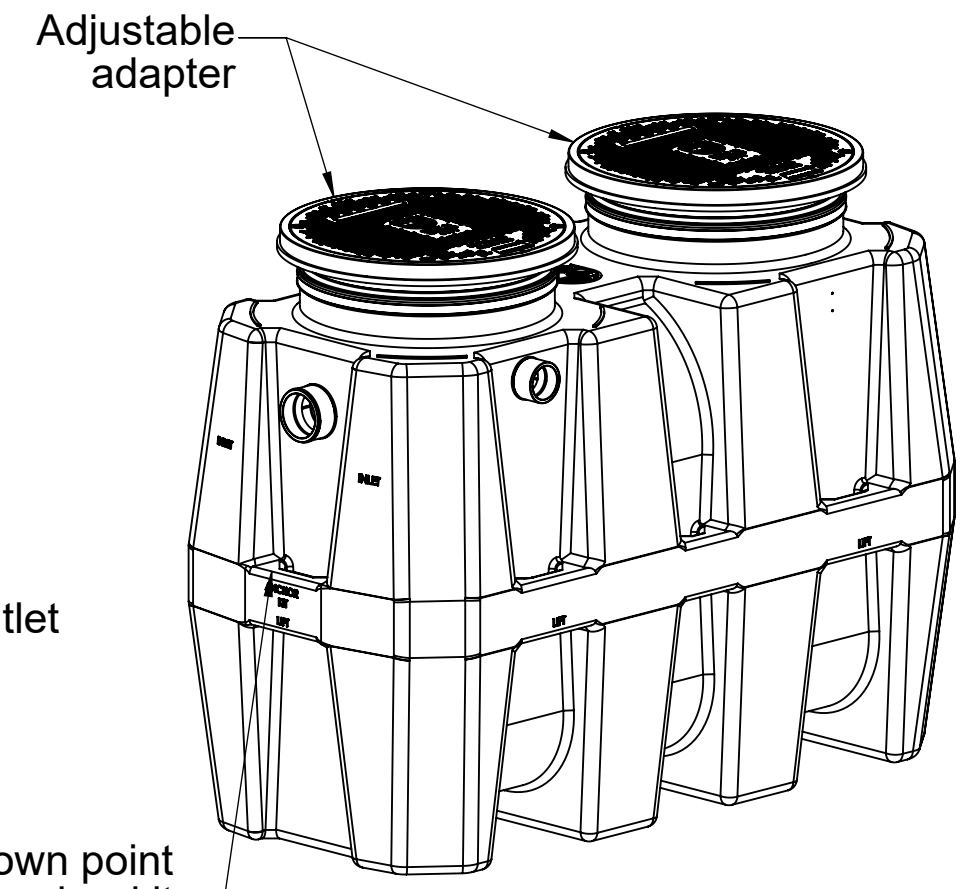

ISOMETRIC VIEW

ENGINEER SPECIFICATION GUIDE

Striem Flammable Liquid Interceptor model FLI-275 shall be lifetime guaranteed and made in the USA of seamless, rotationally-molded polyethylene. Interceptor shall be furnished for above or below grade installation, with field adjustable riser system, and (2) vent connections. Interceptor capacity shall be 129 gallons of flammable liquids and 111 gallons of sediment. Covers shall provide water/gas-tight seal and have a maximum 16,000 lbs load capacity.

OPTIONS

- 4M** - 4" Male Thread Inlet / Outlet
- 6P** - 6" Plain End Inlet / Outlet
- 6M** - 6" Male Thread Inlet / Outlet
- CC24 (2)** - Integral Membrane Clamping Collar Kit
- C24-HP (2)** - H2O Rated Pickable Cast Iron Covers
- AK1** - High Water Anchor Kit

TeleGlide RISER OPTIONS

- SR24 (2)** - >6"-24"
- LR24 (2)** - >24"-39"
- SR24 (4)** - >39"-43"
- SR24 (2) + LR24 (2)** - >43"-58"
- LR24 (4)** - >58"-72"

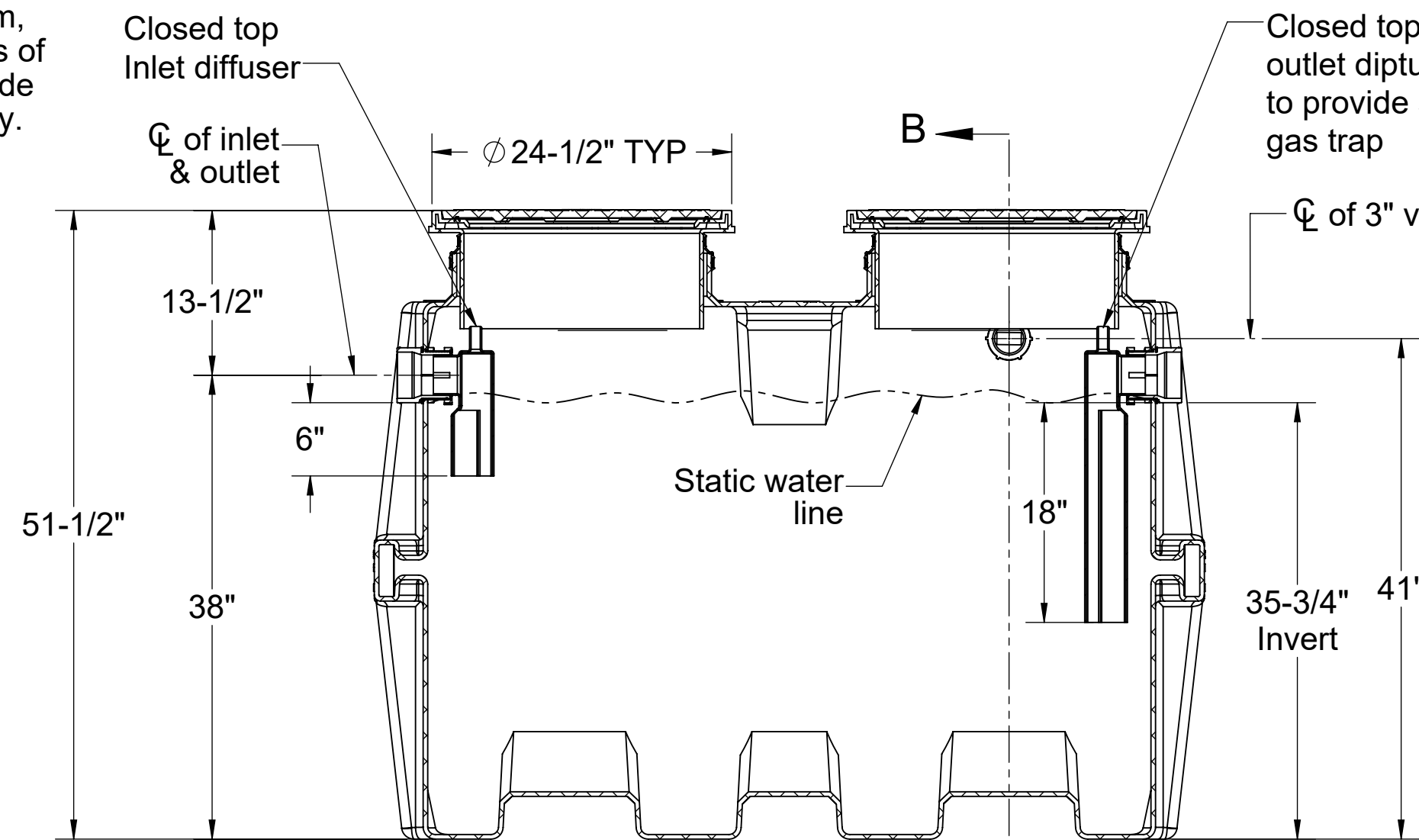

SECTION "A-A"

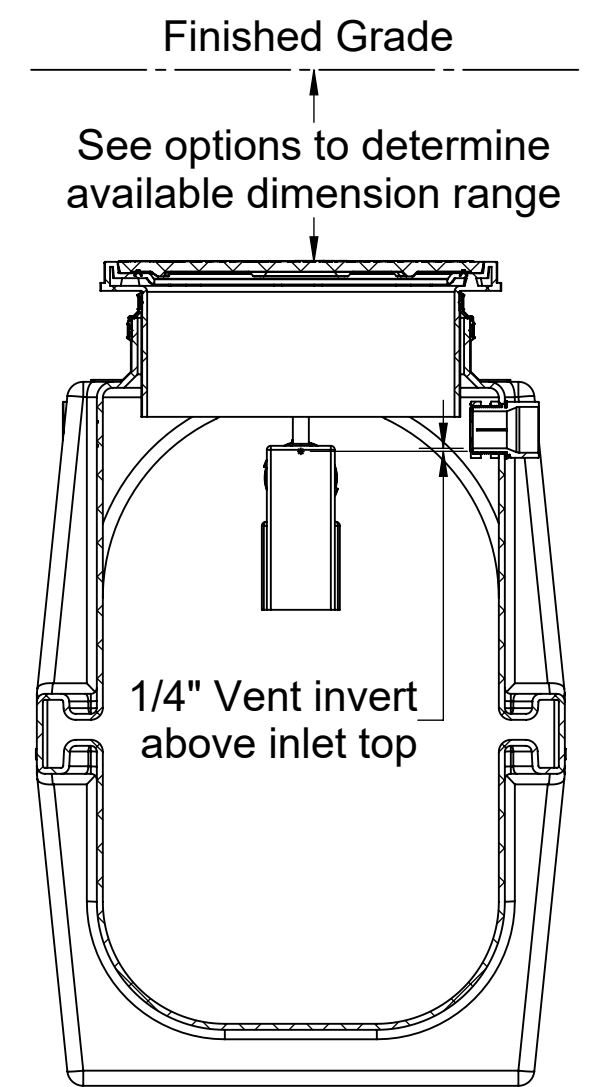

SECTION "B-B"

Signature of Approval: _____
 Company: _____
 Date of Approval: _____
 Specifying Engineer: _____
 Engineering Firm: _____

MODEL NUMBER: FLI-275	
DESCRIPTION: 262 GALLON POLYETHYLENE FLAMMABLE LIQUID INTERCEPTOR, UNRATED	
DWG BY: RS	DATE: 6/8/20
REV: 02	ECO:

SPECIFICATION SHEET

Striem
 3100 Brinkerhoff
 Kansas City, KS 66115
 Tel: 913-222-1500
 Fax: 913-291-0457
 www.striemco.com



Made in the U.S.A

PROPRIETARY AND CONFIDENTIAL

THE INFORMATION CONTAINED IN THIS DRAWING IS THE SOLE PROPERTY OF STRIEM, LLC. ANY REPRODUCTION IN PART OR AS A WHOLE WITHOUT THE WRITTEN PERMISSION OF STRIEM, LLC. IS PROHIBITED.