

**SPECIFICATIONS**

1. 4" Plain End inlet/outlet, 3" Plain End vents.
2. Capacities: Liquid: 262 gallons (35 cu.ft.); Sand: 111 gallons.
3. Flammable liquid capacity: 129 gallons.
4. Unit weight with composite cover: 225 lbs.; With cast iron covers: 345 lbs.
5. Maximum operating temperature 140°F continuous.
6. Highway rated covers: 16,000 lb. capacity.

**NOTES**

1. Seamless polyethylene tank.
2. Unit supplied with built-in adapter for up to 5" of adjustability. Additional riser(s) available for deeper burial depth.
3. Cover placement allows full access to tank for proper maintenance.
4. Narrow footprint allows clearance through doorways and down stairs.
5. Outlet diptube is removable to inspect/clean piping.
6. For on-the-floor or buried applications.

**ENGINEER SPECIFICATION GUIDE**

Striem Flammable Liquid Interceptor model FLI-275 shall be lifetime guaranteed and made in the USA of seamless, rotationally-molded polyethylene. Interceptor shall be furnished for above or below grade installation, with field adjustable riser system, and (2) vent connections. Interceptor capacity shall be 129 gallons of flammable liquids and 111 gallons of sediment. Covers shall provide water/gas-tight seal and have a maximum 16,000 lbs load capacity.

**OPTIONS**

- 4M** - 4" Male Thread Inlet / Outlet
- 6P** - 6" Plain End Inlet / Outlet
- 6M** - 6" Male Thread Inlet / Outlet
- CC24 (2)** - Integral Membrane Clamping Collar Kit
- CS3** - Clean Sweep Coalescing Media (single)\*
- CS6** - Clean Sweep Coalescing Media (double)\*
- SS** - Slick Stick™ Oil Level Monitoring Solution\*\*
- C24-HP (2)** - H2O Rated Pickable Cast Iron Covers
- HDK-2** - High Water Anchor Kit

\* Coalescing Media not compatible with CPRK  
 \*\* Monitoring system will raise covers by 3"

**RISER OPTIONS**

- SR24 (2)** - >5"-24"
- LR24 (2)** - >24"-39"
- SR24 (4)** - >39"-43"
- SR24 (2) + LR24 (2)** - >43"-58"
- LR24 (4)** - >58"-72"
- SR24 (2) + LR24 (4)** - >72"-90"

-OR-

- CPRK (2)** : >11" - 90"
  - Corrugated Pipe Riser Kit.
  - 18" diameter corrugated pipe by others.
  - Used in substitute of SR/LR riser options
  - See CPRK specification for more detail.

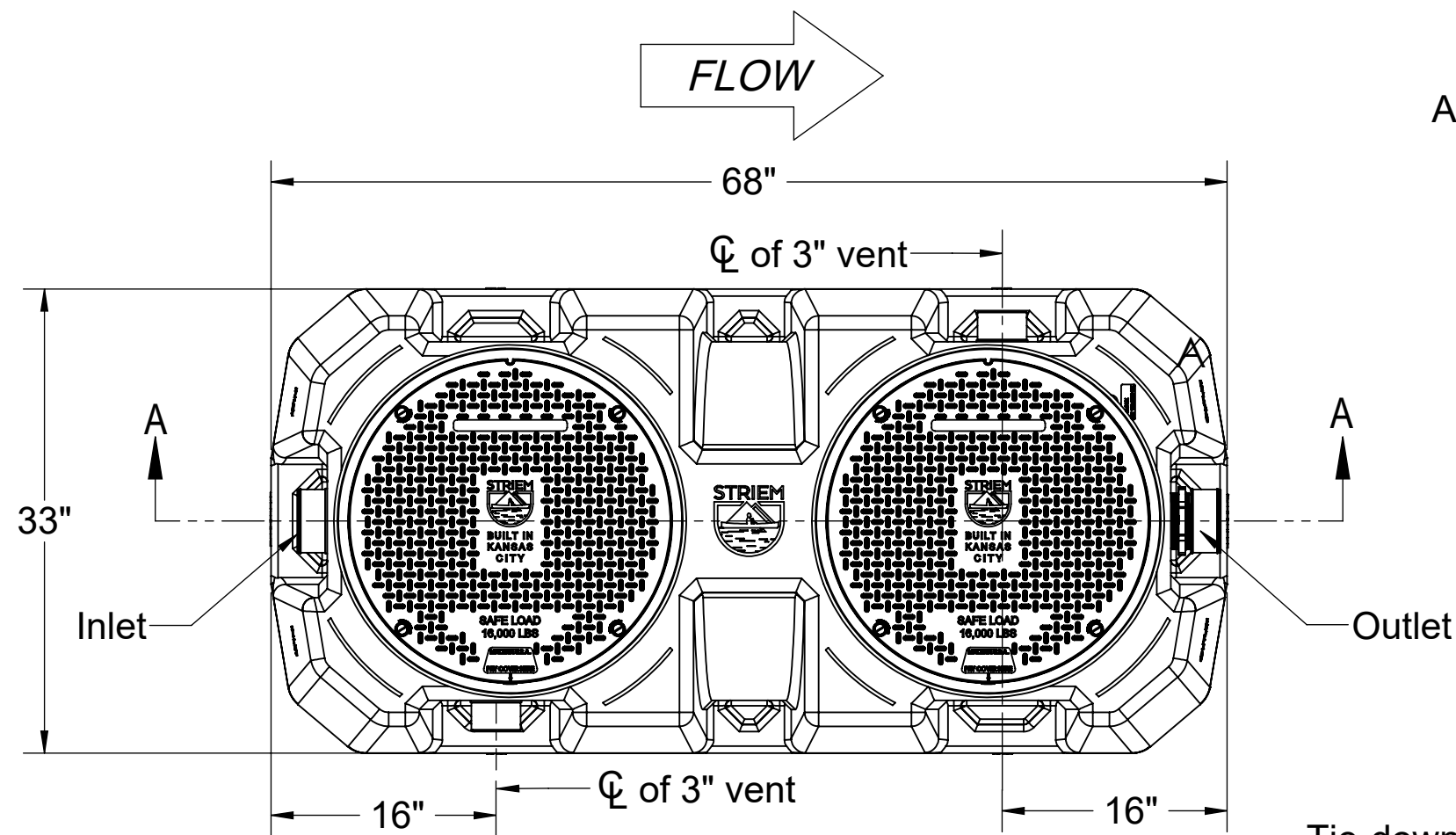

**TOP VIEW**

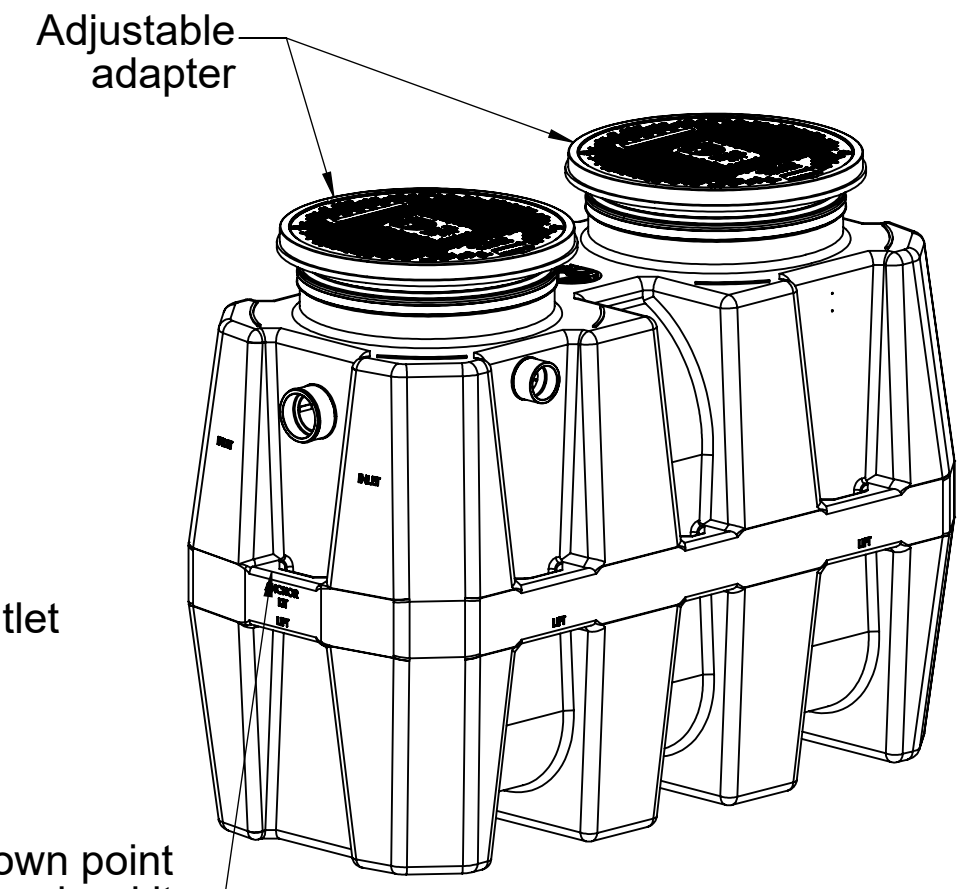

**ISOMETRIC VIEW**

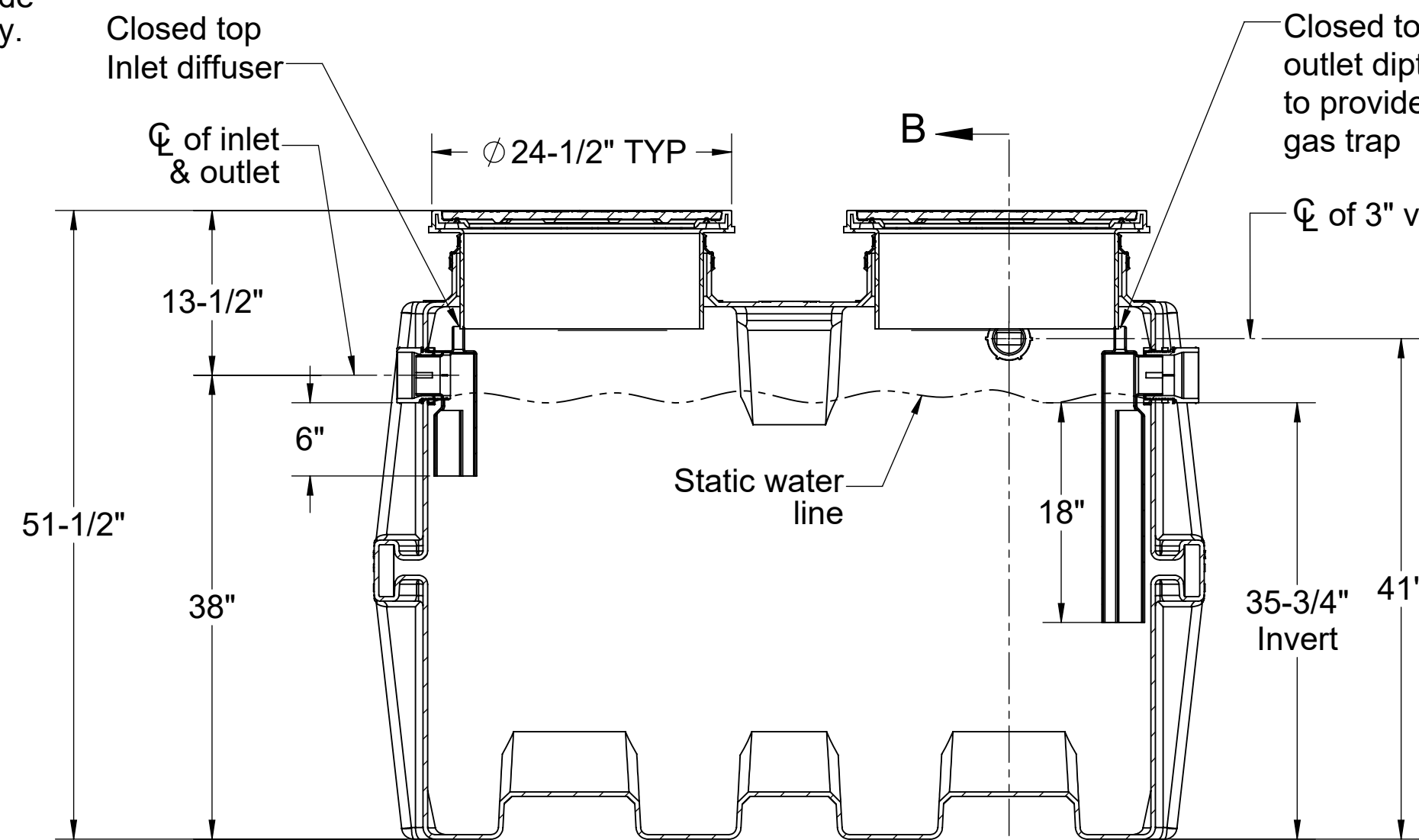

**SECTION "A-A"**

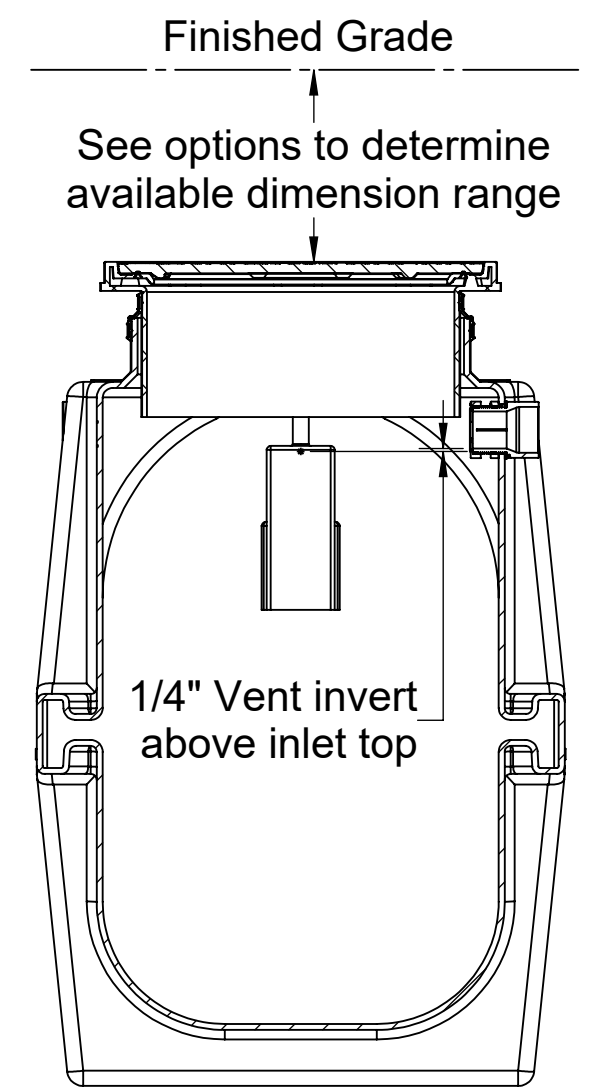

**SECTION "B-B"**

|  |                         |
|--|-------------------------|
| <b>MODEL NUMBER:</b> FLI-275   |                         |
| <b>DESCRIPTION:</b><br>262 GALLON POLYETHYLENE FLAMMABLE LIQUID INTERCEPTOR, UNRATED |                         |
| <b>DWG BY:</b> MJ  | <b>DATE:</b> 07/14/2021 |
| <b>REV:</b> 02   | <b>ECO:</b>             |

**SPECIFICATION SHEET**

**Striem**  
 3100 Brinkerhoff  
 Kansas City, KS 66115  
 Tel: 913-222-1500  
 orders@striemco.com  
 www.striemco.com



Made in the U.S.A

PROPRIETARY AND CONFIDENTIAL

THE INFORMATION CONTAINED IN THIS DRAWING IS THE SOLE PROPERTY OF STRIEM, LLC. ANY REPRODUCTION IN PART OR AS A WHOLE WITHOUT THE WRITTEN PERMISSION OF STRIEM, LLC. IS PROHIBITED.