

**SPECIFICATIONS (PS-25-S)**

1. 3" inlets/outlets Sch. 40. (No-Hub).
2. Liquid capacity: 21 Gallons.
3. Solids capacity: 10 Gallons.
4. Unit weight w/std. cover: 37 lbs.
5. Standard cover handles 450 lbs. when unit is installed above-grade. and 2,500 lbs. when buried with SR16 riser.
6. Maximum operating temperature 140 °F continuous.

**NOTES**

1. For gravity drainage applications only. Do not use for pressure applications.
2. 3/8" thick seamless polyethylene walls.
3. Cover placement allows full access to tank for proper maintenance.
4. Internal components are removable for easy maintenance.
5. For on-the-floor or buried applications.

**ENGINEER SPECIFICATION GUIDE**

Striem Prospector™ solids interceptor model PS-25-S shall be lifetime guaranteed and Made in USA of seamless, rotationally-molded Medium Density Polyethylene with minimum 3/8" uniform wall thickness. Interceptor shall be furnished for above or below-grade installation. Interceptor shall be furnished with filter screen and connection for extending handle for burial. Cover shall provide water/gas-tight seal and have a maximum 450 lbs load capacity when unit is installed above-grade, and 2,500 lbs. when buried with SR16 riser.

**OPTIONS**

- 2P** - 2" Plain end inlet/outlet
- 2M** - 2" Male thread inlet/outlet
- 3M** - 3" Male thread inlet/outlet
- C** - Course filter screen (openings 0.3" x 0.27")
- M** - Medium filter screen (openings 0.1" x 0.08")
- F** - Fine filter screen (openings 0.03" x 0.025")

**RISER OPTIONS**

- SR16** - 4"-16" 16 series riser
- CC16** - 4"-16" 16 series riser with integral membrane clamping collar kit

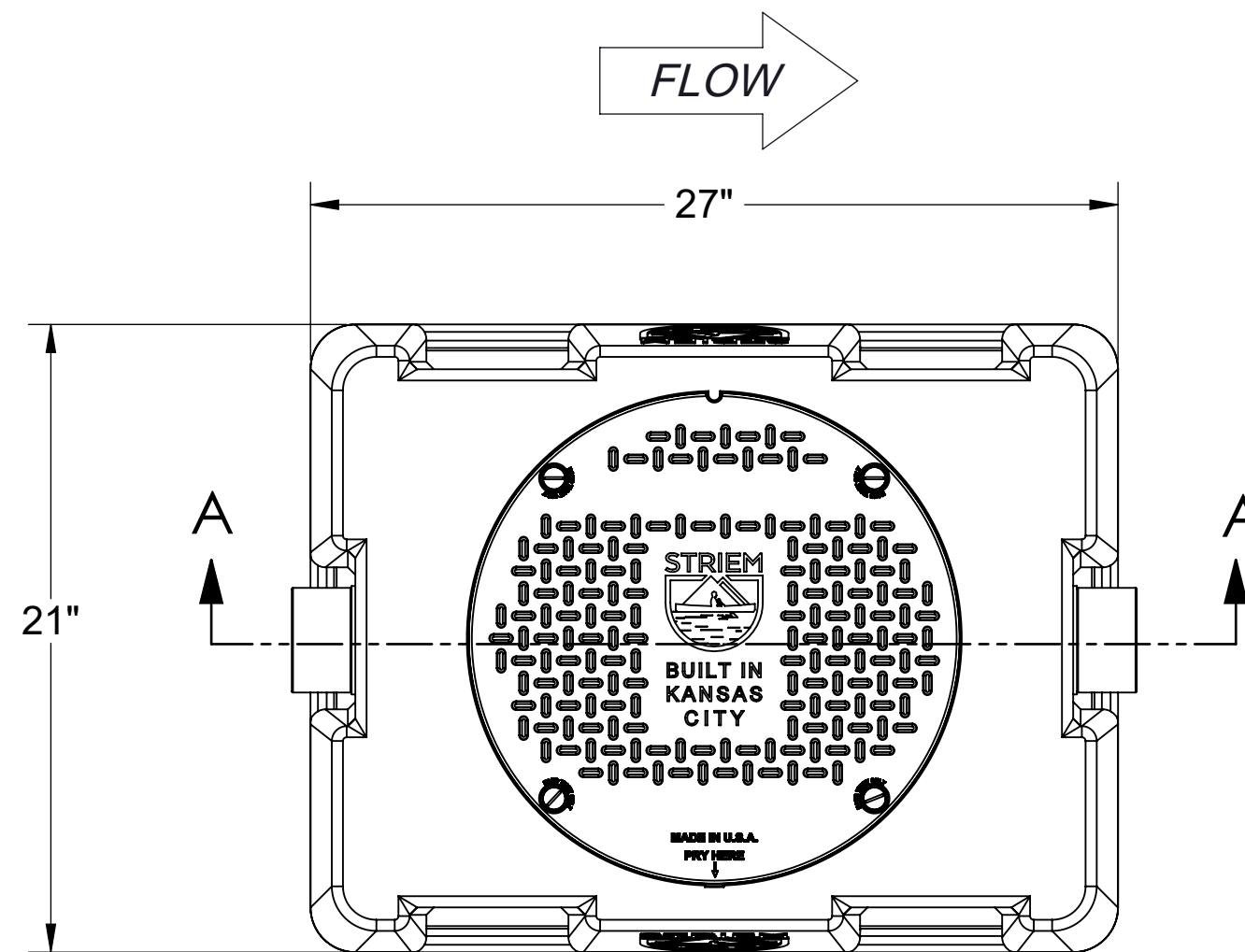

**TOP VIEW**

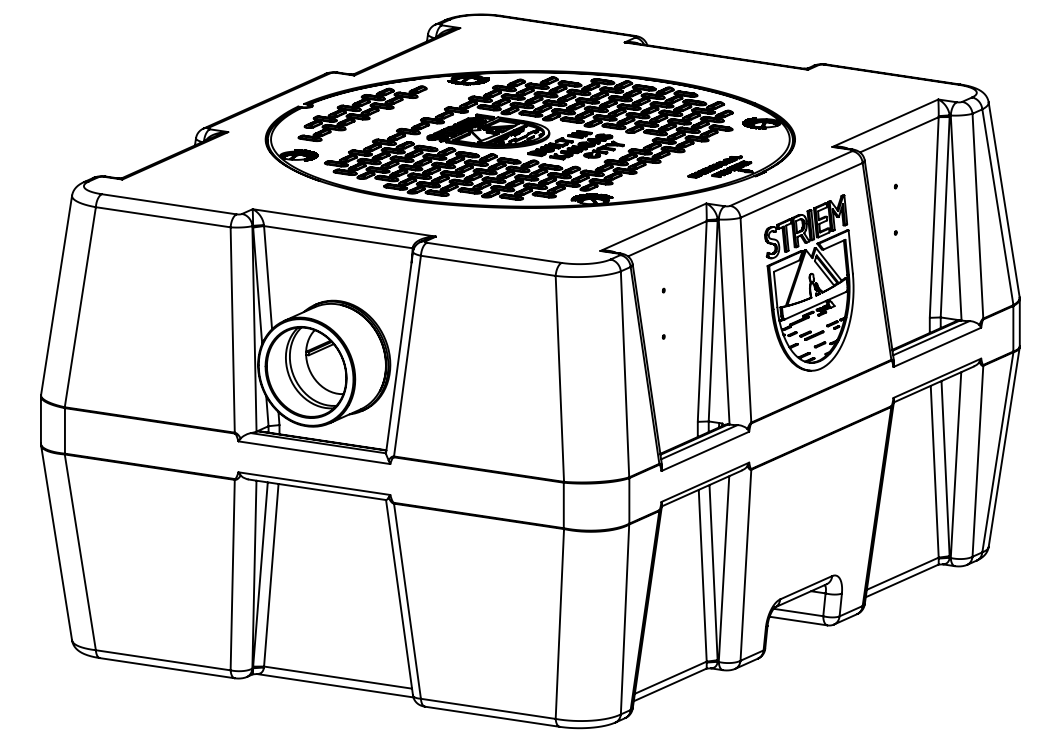

**ISOMETRIC VIEW**

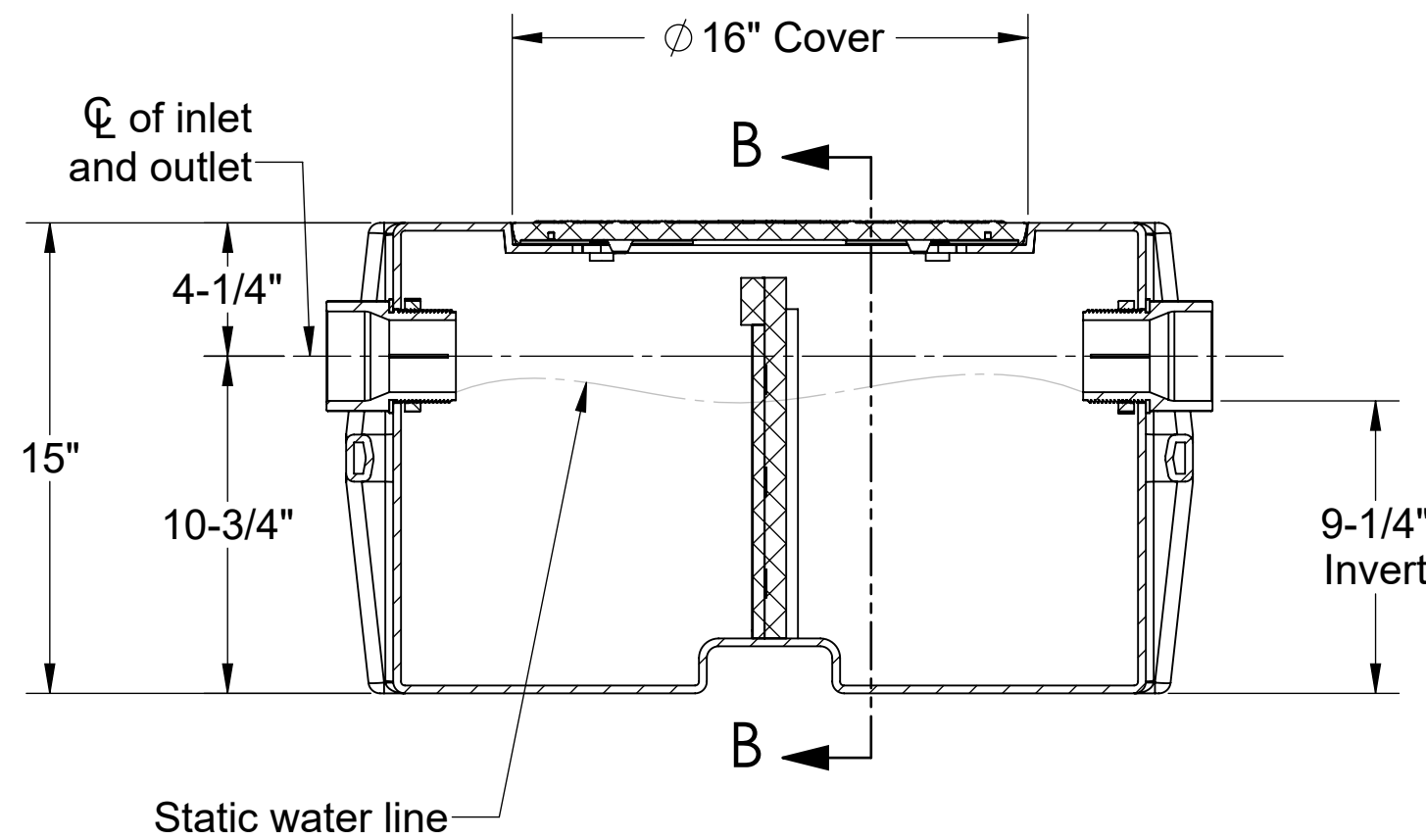

**SECTION "A-A"**

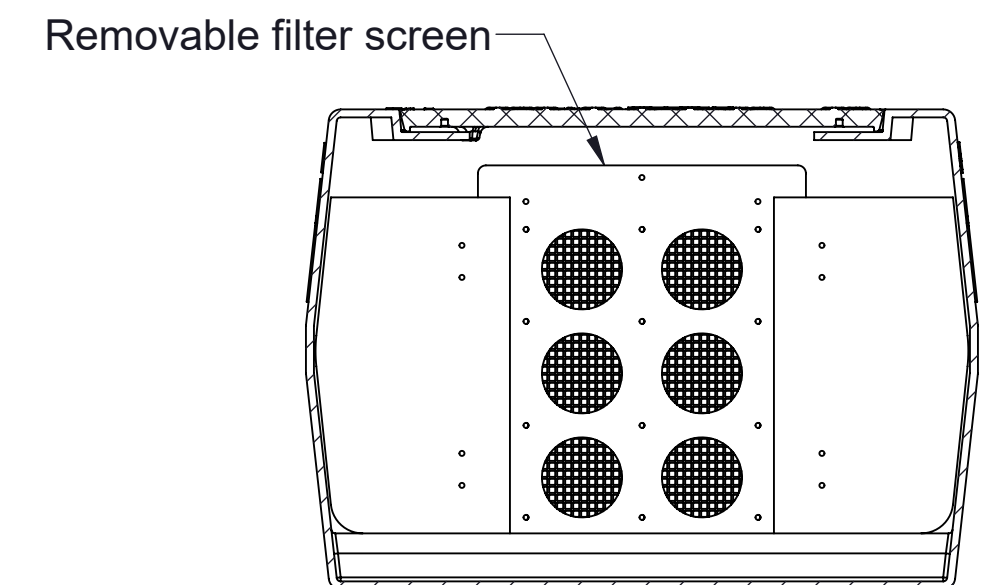

**SECTION "B-B"**

<b>MODEL NUMBER:</b>	PS-25-S
<b>DESCRIPTION:</b>	PROSPECTOR SERIES POLYETHYLENE SCREEN STYLE SOLIDS INTERCEPTOR 21 LIQUID GALLON CAPACITY
<b>DWG BY:</b> MJ	<b>DATE:</b> 06/29/2021 <b>REV:</b> 02 <b>ECO:</b>

**SPECIFICATION SHEET**

**Striem**  
 3100 Brinkerhoff  
 Kansas City, KS 66115  
 Tel: 913-222-1500  
 orders@striemco.com  
 www.striemco.com

**Made in the U.S.A**