

SPECIFICATIONS (PS-50-S)

1. 4" inlet/outlets Sch. 40. (No-Hub)
2. Liquid capacity: 57 Gallons
3. Solids capacity: 29 Gallons
4. Unit weight w/std. covers: 100 lbs.
5. 2,000 lb. load rated, bolted, gas/water tight composite cover.
6. Maximum operating temperature 140 °F continuous.

NOTES

1. For gravity drainage applications only. Do not use for pressure applications.
2. 3/8" thick seamless polyethylene walls.
3. Unit supplied with built-in adapter for up to 3-1/2" of adjustability. Additional riser(s) are also available for deeper burial depth.
4. Cover placement allows full access to tank for proper maintenance.
5. Internal components are removable for easy maintenance.
6. For on-the-floor or buried applications.

ENGINEER SPECIFICATION GUIDE

Striem Prospector™ solids interceptor model PS-50-S shall be lifetime guaranteed and Made in USA of seamless, rotationally-molded Medium Density Polyethylene with minimum 3/8" uniform wall thickness. Interceptor shall be furnished for above or below-grade installation. Interceptor shall be furnished with filter screen and connection for extending handle for deep burials. Cover shall provide water/gas-tight seal and have a maximum 2,000 lbs load capacity.

OPTIONS

- 2P** - 2" Plain end inlet/outlet
- 2M** - 2" Male thread inlet/outlet
- 3P** - 3" Plain end inlet/outlet
- 3M** - 3" Male thread inlet/outlet
- 4M** - 4" Male thread inlet/outlet
- AK-1** - High water table 304 stainless steel anchor kit
- C24-H** - Highway rated bolted composite cover
- C24-HP** - H20 rated pickable cast iron cover
- C** - Course filter screen (openings 0.3 x 0.27")
- M** - Medium filter screen (openings 0.1 x 0.08")
- F** - Fine filter screen (openings 0.03 x 0.025")

TeleGlide Riser Order Guide

- SR24** - 3-1/2"-22"
- LR24** - 22"-37"

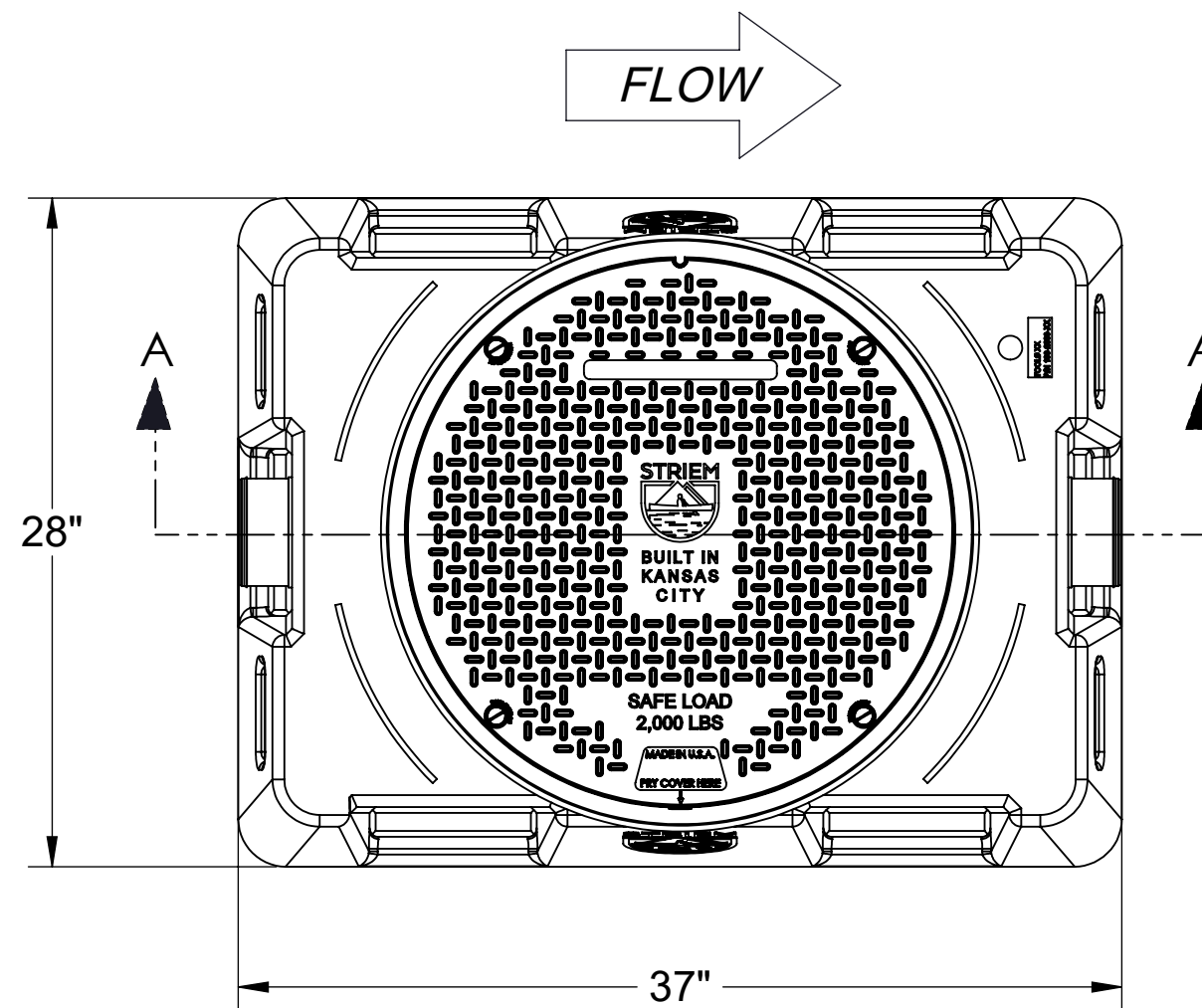

TOP VIEW

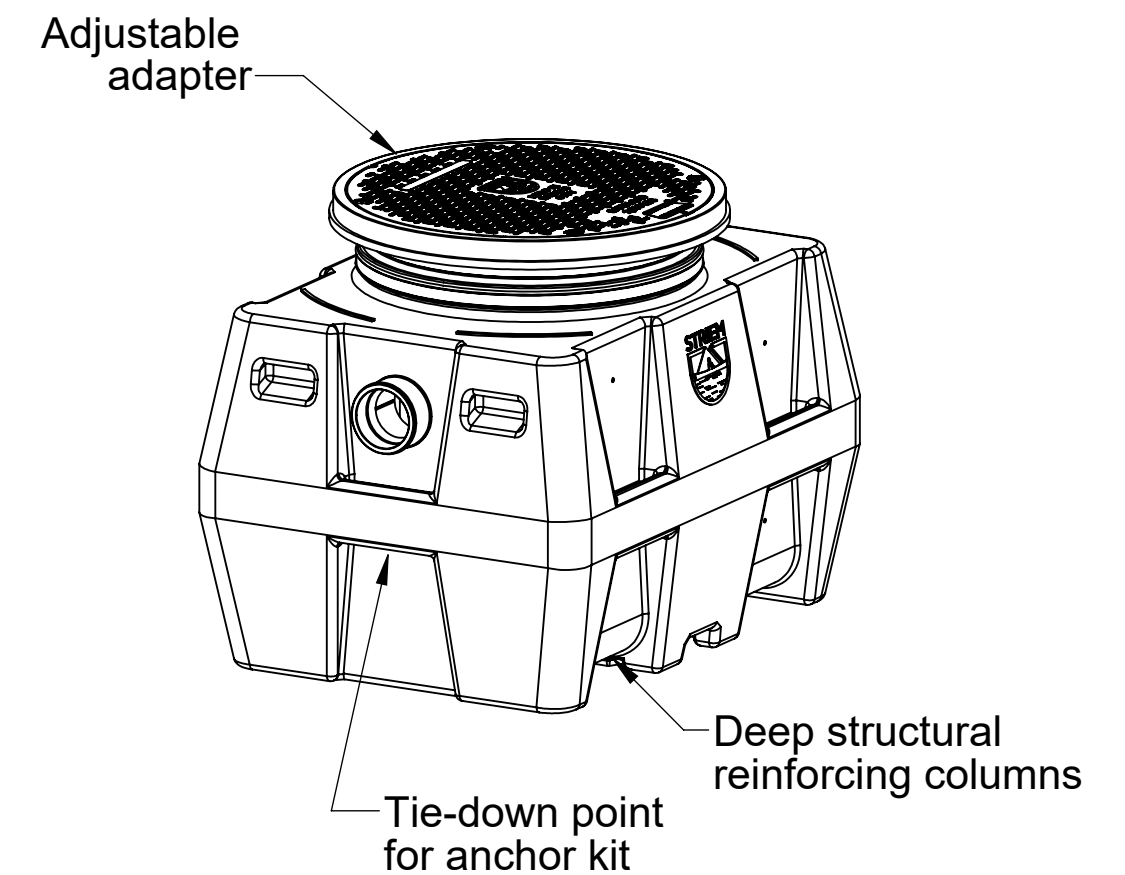

ISOMETRIC VIEW

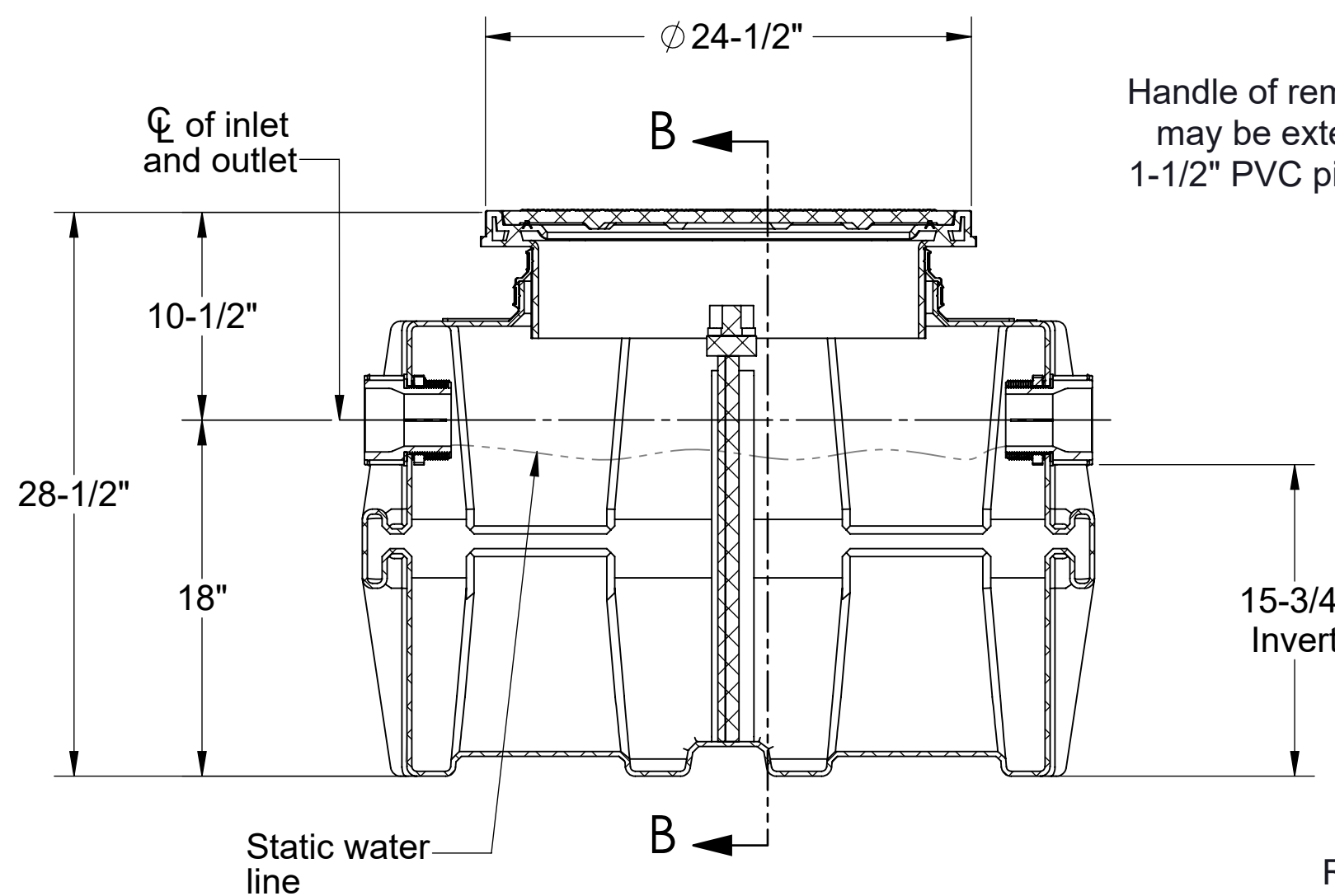

SECTION "A-A"

Handle of removable screen may be extended by using 1-1/2" PVC pipe. (by others)

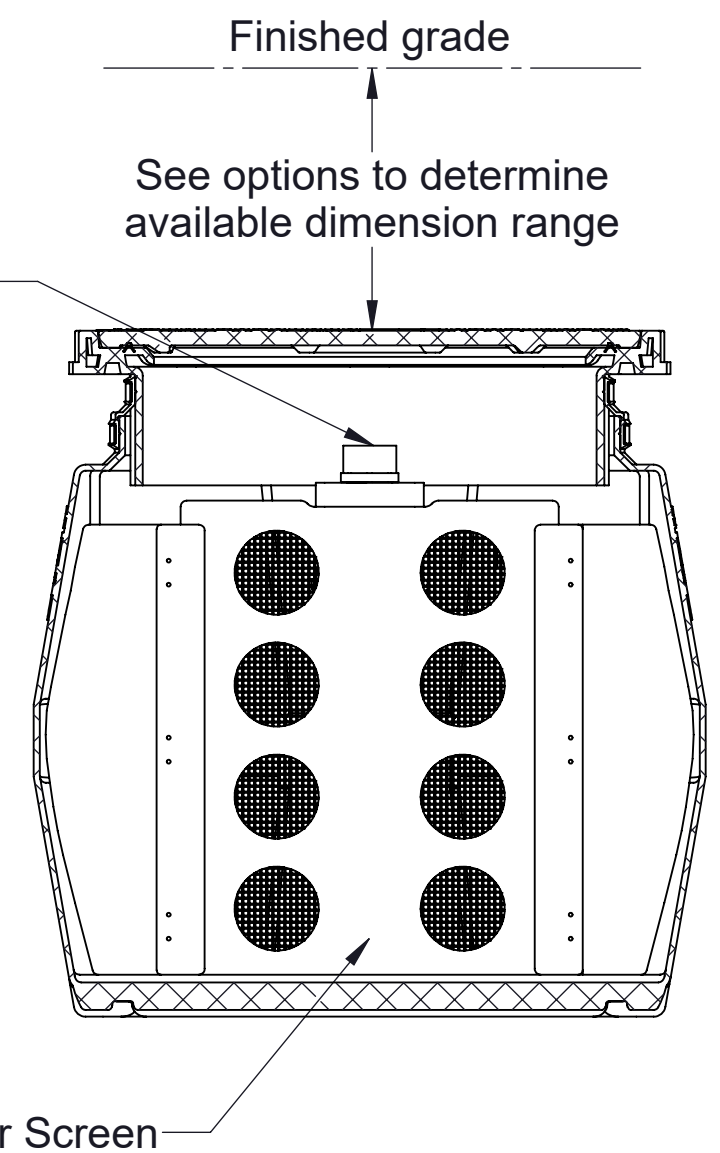

SECTION "B-B"

MODEL NUMBER:	PS-50-S
DESCRIPTION:	PROSPECTOR SERIES POLYETHYLENE SCREEN STYLE SOLIDS INTERCEPTOR 57 LIQUID GALLON CAPACITY
DWG BY: MJ	DATE: 01/24/19
REV: 0	ECO:

SPECIFICATION SHEET

Striem
3100 Brinkerhoff
Kansas City, KS 66115
Tel: 913-222-1500
Fax: 913-291-0457
www.striemco.com

Made in the U.S.A

PROPRIETARY AND CONFIDENTIAL

THE INFORMATION CONTAINED IN THIS DRAWING IS THE SOLE PROPERTY OF STRIEM, LLC. ANY REPRODUCTION IN PART OR AS A WHOLE WITHOUT THE WRITTEN PERMISSION OF STRIEM, LLC. IS PROHIBITED.