

SPECIFICATIONS

1. 4" inlet/outlet Sch. 40. Plain End (No-Hub).
2. Liquid capacity: 57 Gallons.
3. Solids capacity: 25 Gallons.
4. Unit weight w/std. covers: 92 lbs.
5. Highway rated cover: 16,000 lbs capacity.
6. Maximum operating temperature 140°F continuous.

NOTES

1. For gravity drainage applications only. Do not use for pressure applications.
2. 3/8" thick seamless polyethylene tank.
3. Unit supplied with built-in adapter for up to 3-1/2" of adjustability. Additional riser(s) available for deeper burial depth.
4. Cover placement allows full access to tank for proper maintenance.
5. Designed narrow footprint allows clearance through doorways and down stairwells.
6. Diffuser is removable to inspect or clean piping.
7. For on-the-floor or buried applications.

ENGINEER SPECIFICATION GUIDE

Striem Settler™ catch basin model CB-50-S shall be lifetime guaranteed and made in USA of seamless, rotationally-molded polyethylene with a minimum 3/8" uniform wall thickness. Catch basin shall be provided with outlet and inlet connection. Cover shall provide water/gas-tight seal and have a maximum 16,000 lbs load capacity.

THIRD PARTY STRUCTURAL ANALYSIS

The CB-50-S has been structurally analyzed in accordance with the requirements of IBC 2012 and ASCE/SEI 7 for direct burial. The maximum burial depth and backfill material are specified in our installation instructions. The structural design has been reviewed and sealed by a professional engineer registered in the state of California. A sealed structural analysis report is available upon request.

OPTIONS

- 3P - 3" Plain end SCH.40 inlet / outlet
- 3M - 3" Male thread inlet / outlet
- 4M - 4" Male thread inlet / outlet
- C24-HP - H2O rated pickable cast iron cover
- CC24 - Integral membrane clamping collar kit
- AK1 - High water table 304 stainless steel anchor kit

TeleGlide RISER OPTIONS

- SR24 - >3-1/2"-22"
- LR24 - >22"-37"

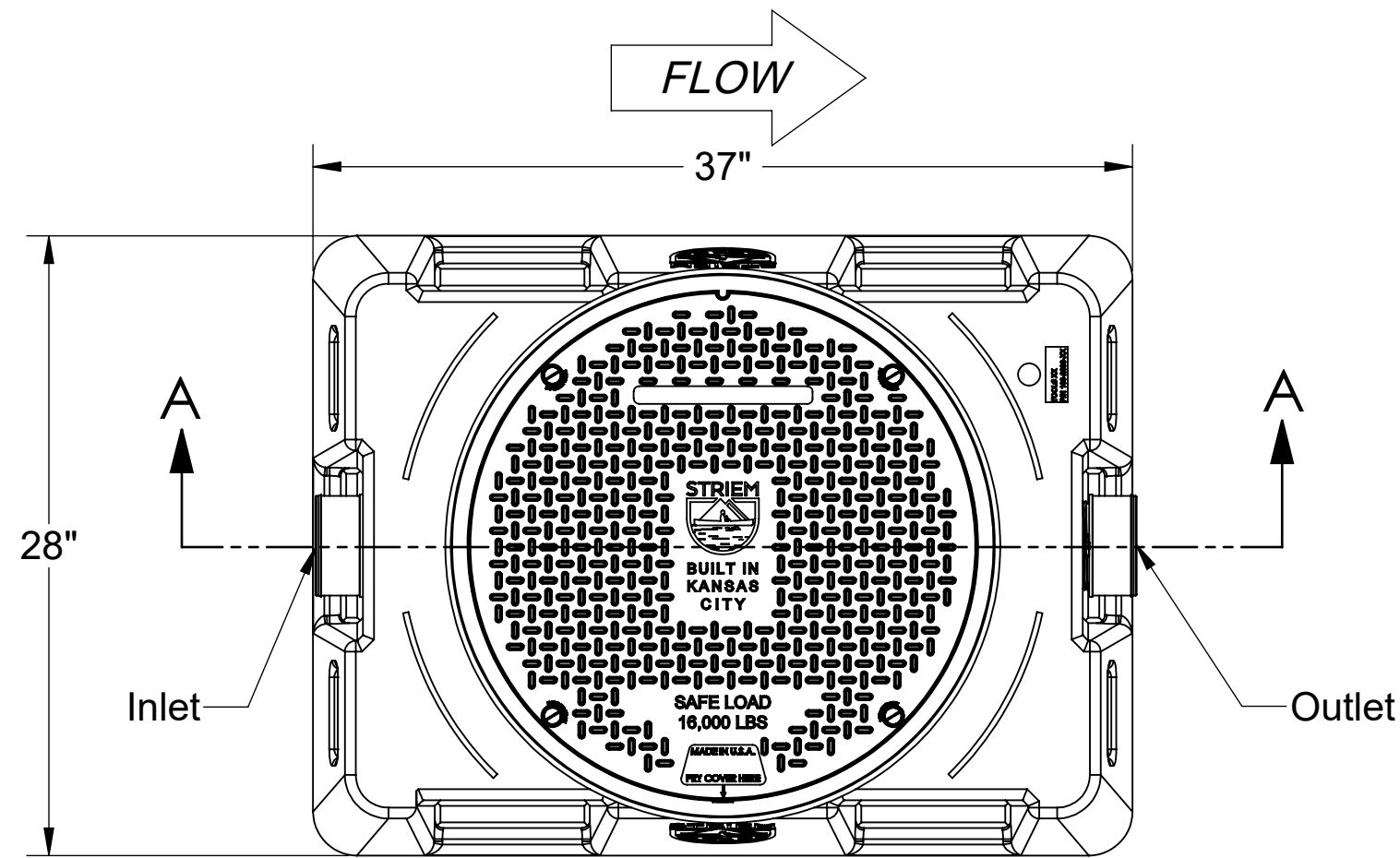

TOP VIEW

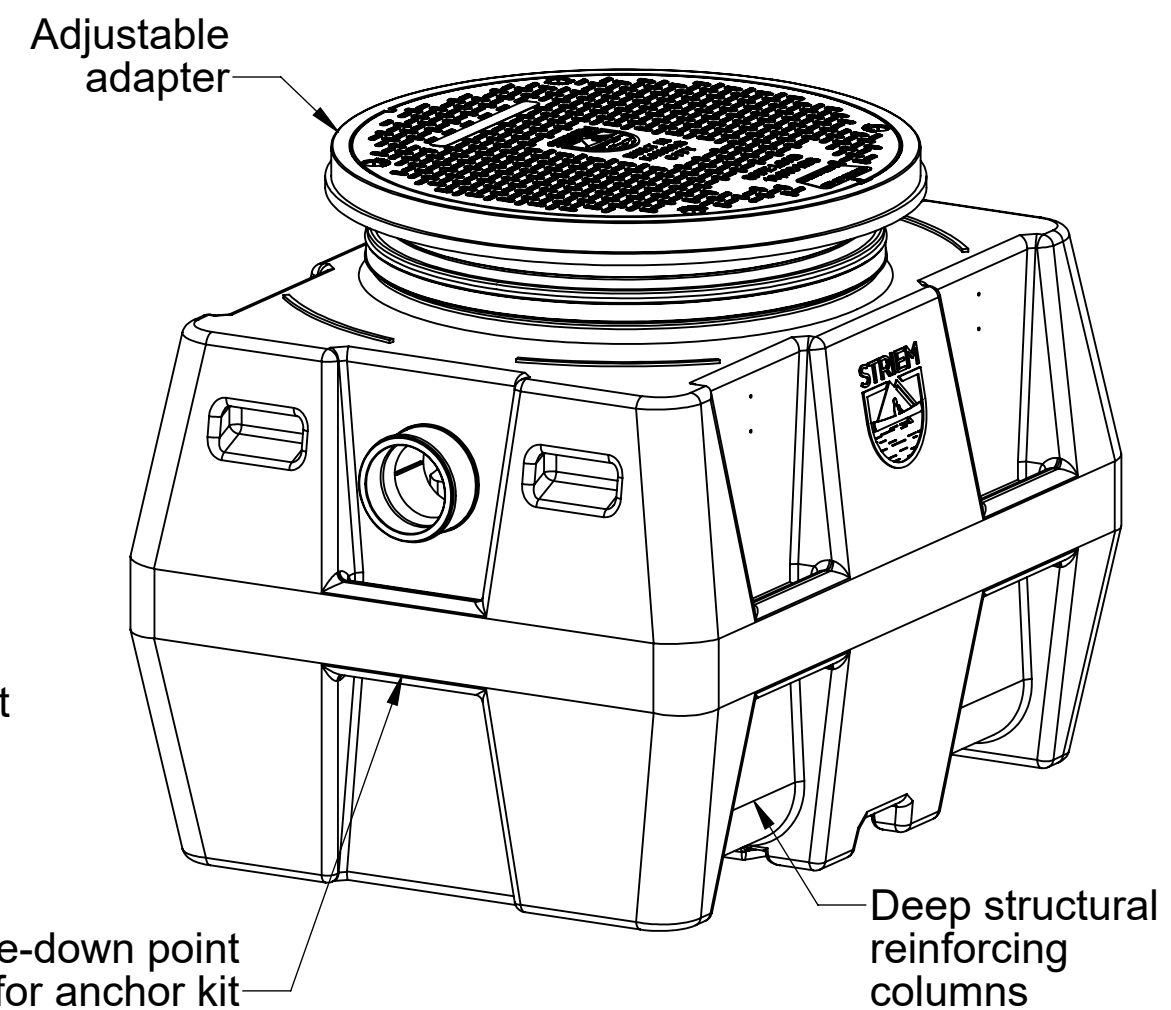

ISOMETRIC VIEW

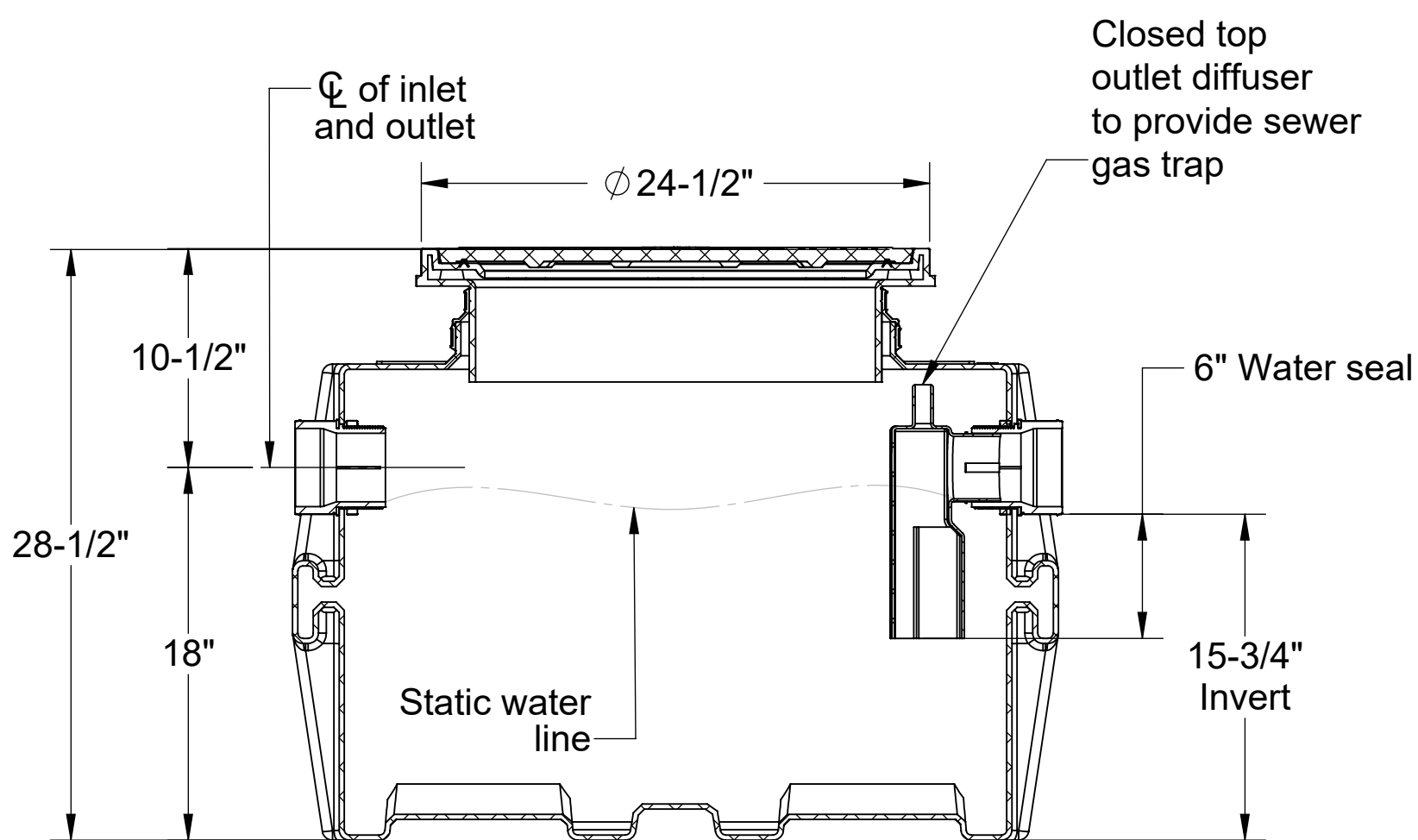

SECTION "A-A"

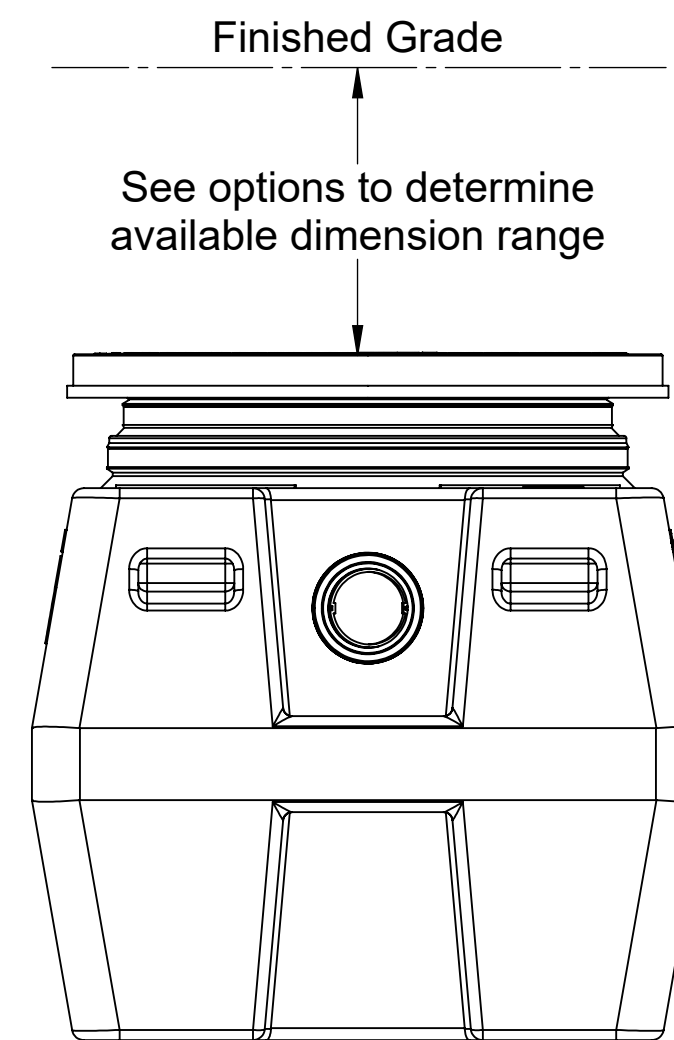

OUTLET END VIEW

MODEL NUMBER: CB-50-S	
DESCRIPTION: SETTLER SERIES POLYETHYLENE CATCH BASIN	
DWG BY: MJ	DATE: 04/29/2020 REV: 0 ECO:

SPECIFICATION SHEET

Striem
3100 Brinkerhoff
Kansas City, KS 66115
Tel: 913-222-1500
Fax: 913-291-0457
www.striemco.com



Made in the U.S.A

PROPRIETARY AND CONFIDENTIAL

THE INFORMATION CONTAINED IN THIS DRAWING IS THE SOLE PROPERTY OF STRIEM, LLC. ANY REPRODUCTION IN PART OR AS A WHOLE WITHOUT THE WRITTEN PERMISSION OF STRIEM, LLC. IS PROHIBITED.