

**SPECIFICATIONS**

1. 6" Plain End inlet/outlets.
2. Max flow rate: 150 GPM.
3. Liquids Capacity with high outlet: 104 gal.
4. Liquids Capacity with low outlet: 15 gal.
5. Solids Capacity: 10 gal.
6. Screen Perforations: 1/8" diameter.
7. Unit weight w/std. covers: 143 lbs.
8. Highway rated composite cover: 16,000 lbs. capacity.
9. Maximum operating temperature: 140°F continuous.

**NOTES**

1. Seamless medium density polyethylene 3/8" wall tank.
2. Cover placement allows full access to tank for proper maintenance.
3. For on the-floor or buried applications.

**INNOVATIONS**

1. **Removable basket interlocks with inlet:** prevents solids from escaping basket.
2. **UNI-FIT™:** basket inserts in one orientation.
3. **All-perforated basket:** basket perforations are more than 11 times inlet opening, creating easy flow in the presence of solids, and limiting the chance for a backup.
4. **Optional low outlet:** if used, it allows for a temporary water surge (acts as a reservoir), as well as keeps basket dry during maintenance.

**ENGINEER SPECIFICATION GUIDE**

Striem Aardvark™ solids interceptor model AA-XL-6 shall be lifetime guaranteed and made in the USA. Tank material shall be polyethylene. Interceptor shall have removable, corrosion-resistant filter basket. Interceptor shall be equipped with high or low outlet option, with a sewer gas trap to be located on either outlet. Interceptor shall be furnished for above- or below-grade installation. Cover shall be water and gas tight with a minimum 16,000 lbs load capacity. Interceptor shall be certified to IAPMO IGC 167-2011ae2.

**OPTIONS**

- HO** - High Outlet Option\*
- LO** - Low Outlet Option\*
- HDK-2** - High Water Anchor Kit
- CC24** - Integral Membrane Clamping Collar Kit
- C24-HP** - H2O Rated Pickable cast iron cover

\*With 6" options, only the high or low outlet will be installed at factory.

**TeleGlide RISER OPTIONS**

- SR24** - >5"-24"
- LR24** - >24"-39"
- SR24 (2)** - >39"-43"
- LR24 + SR24** - >43"-58"
- LR24 (2)** - >58"-72"

Signature of Approval: \_\_\_\_\_  
 Company: \_\_\_\_\_  
 Date of Approval: \_\_\_\_\_  
 Specifying Engineer: \_\_\_\_\_  
 Engineering Firm: \_\_\_\_\_

US Patent No.  
 US10786761B2

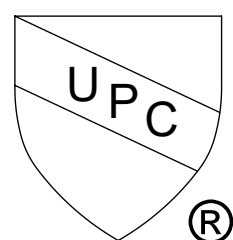

PROPRIETARY AND CONFIDENTIAL

THE INFORMATION CONTAINED IN THIS DRAWING IS THE SOLE PROPERTY OF STRIEM, LLC. ANY REPRODUCTION IN PART OR AS A WHOLE WITHOUT THE WRITTEN PERMISSION OF STRIEM, LLC. IS PROHIBITED.

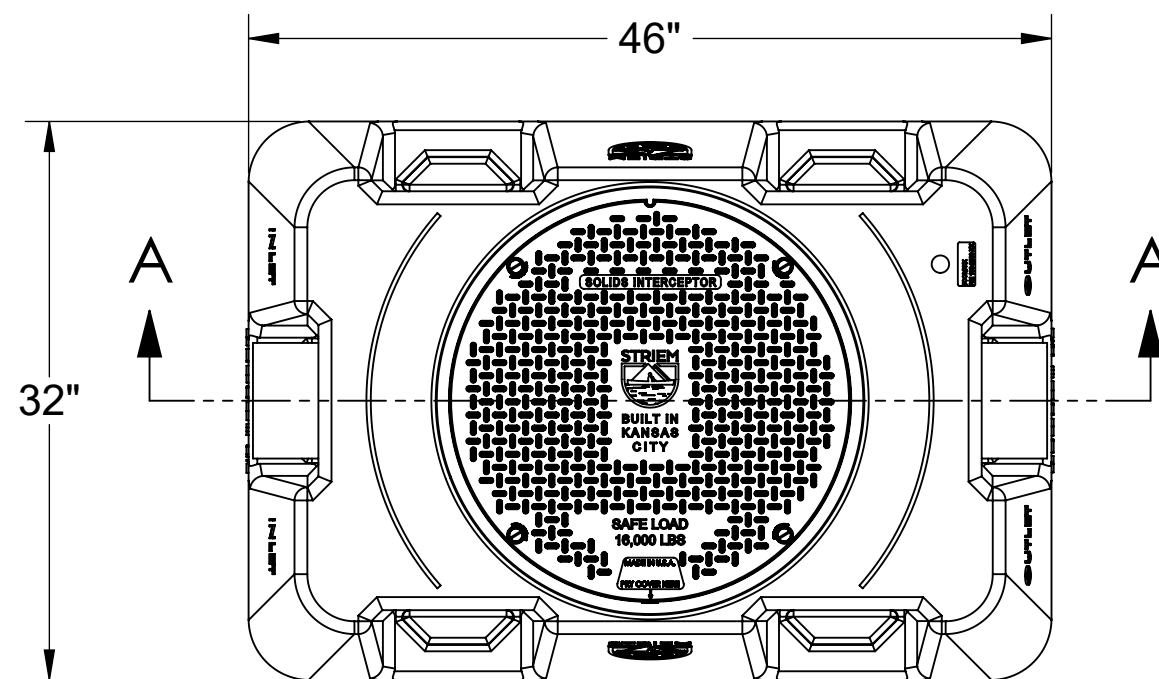

**TOP VIEW**

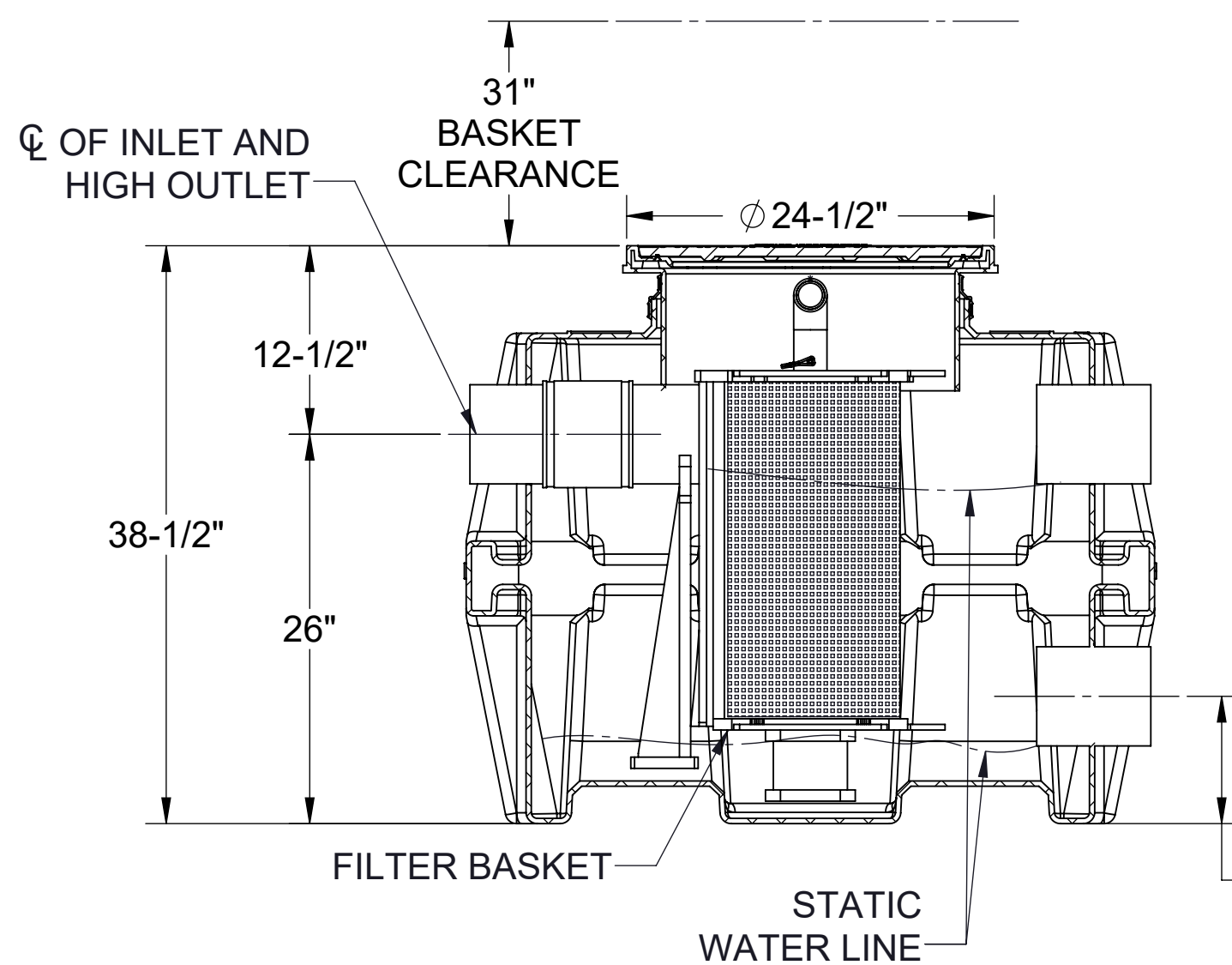

**SECTION "A-A"**

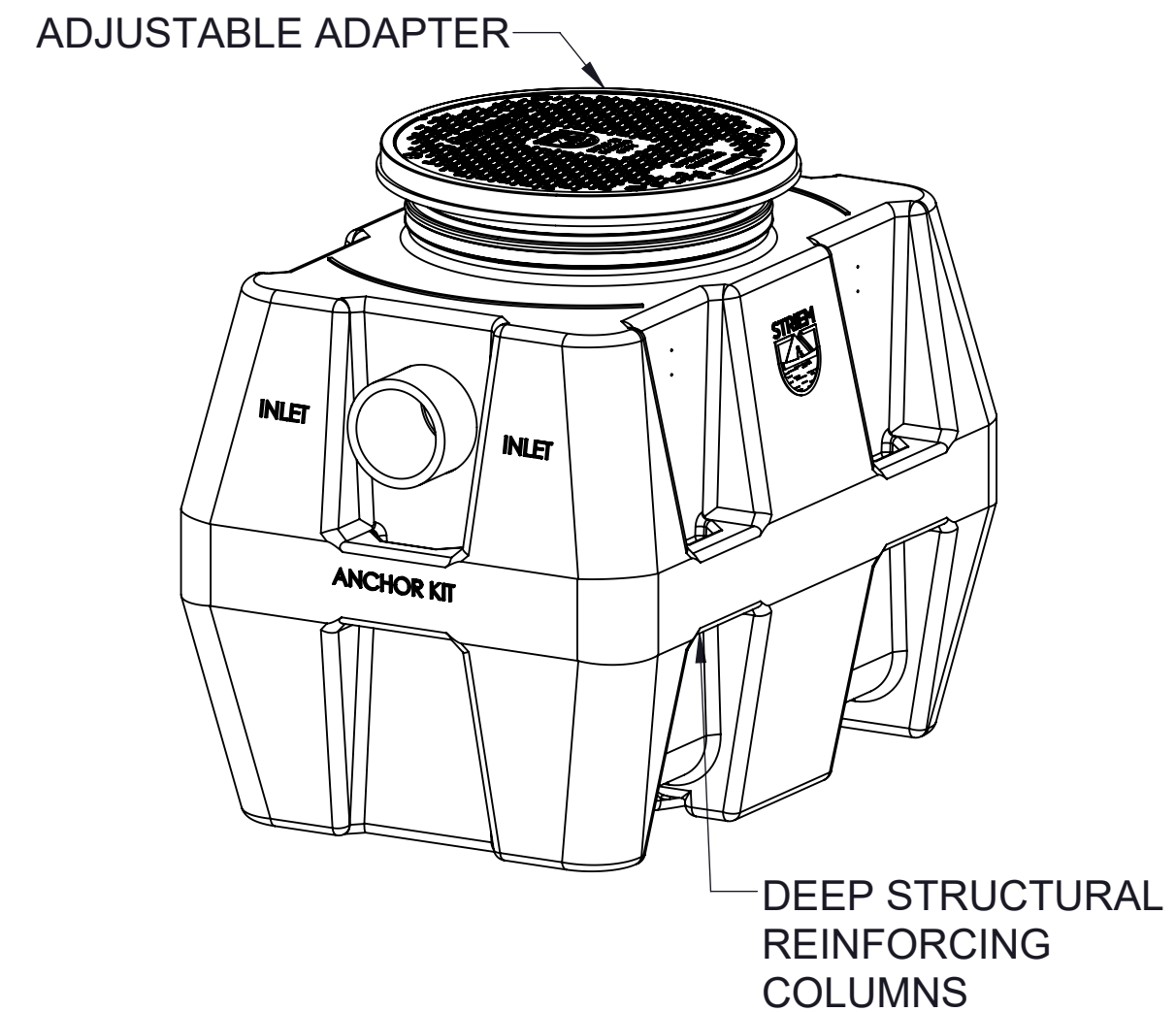

**ISOMETRIC VIEW**

FINISHED GRADE  
 SEE OPTIONS TO DETERMINE AVAILABLE DIMENSION RANGE

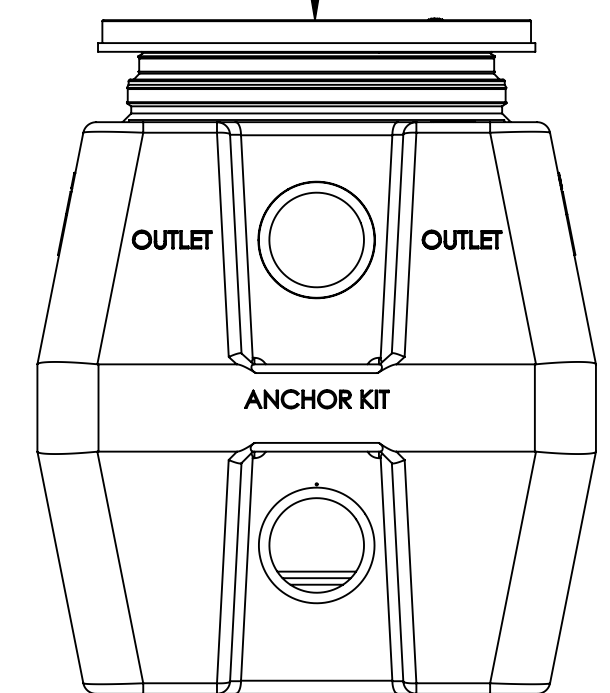

**OUTLET END VIEW**

<b>MODEL NUMBER:</b> AA-XL-6	
<b>DESCRIPTION:</b> AARDVARK™ EXTRA LARGE BASKET-STYLE SOLIDS INTERCEPTOR	
<b>DWG BY:</b> MJ	<b>DATE:</b> 03/22/2021
<b>REV:</b> 0	<b>ECO:</b>

**SPECIFICATION SHEET**

**Striem**  
 3100 Brinkerhoff  
 Kansas City, KS 66115  
 Tel: 913-222-1500  
 orders@striemco.com  
 www.striemco.com

**Made in the U.S.A**