

SPECIFICATIONS

1. Liquid holding capacity: 110 Gallons
2. Unit weight w/std. cover: 130 Pounds
3. Highway rated bolted composite cover.
4. Maximum operating temperature 140°F continuous.

NOTES

1. For gravity drainage applications only. Do not use for pressure applications.
2. 3/8" thick seamless medium density polyethylene walls.
3. Unit supplied with built-in adapter(s) for up to 6" of adjustability. Additional riser(s) available for deeper burial depth.
4. Cover placement allows full access to tank for proper maintenance.
5. Engineered inlet diffuser is removable to inspect/clean piping.
6. For on the-floor or buried applications.

ENGINEER SPECIFICATION GUIDE

Striem Lab Basin™ neutralization tank model LB-125 shall be lifetime guaranteed and Made in USA of seamless, rotationally-molded polyethylene with minimum 3/8" uniform wall thickness. Tank shall be furnished with inlets, outlets, (2) vent connections, cover, riser system, monitoring equipment and other modifications per jobsite-specific conditions and per engineer's specification.

THIRD PARTY STRUCTURAL ANALYSIS

The LB-125 has been structurally analyzed in accordance with the requirements of IBC 2012 and ASCE/SEI 7 for direct burial. The maximum burial depth and backfill material are specified in our installation instructions. The structural design has been reviewed and sealed by a professional engineer registered in the state of California. A sealed structural analysis report is available upon request.

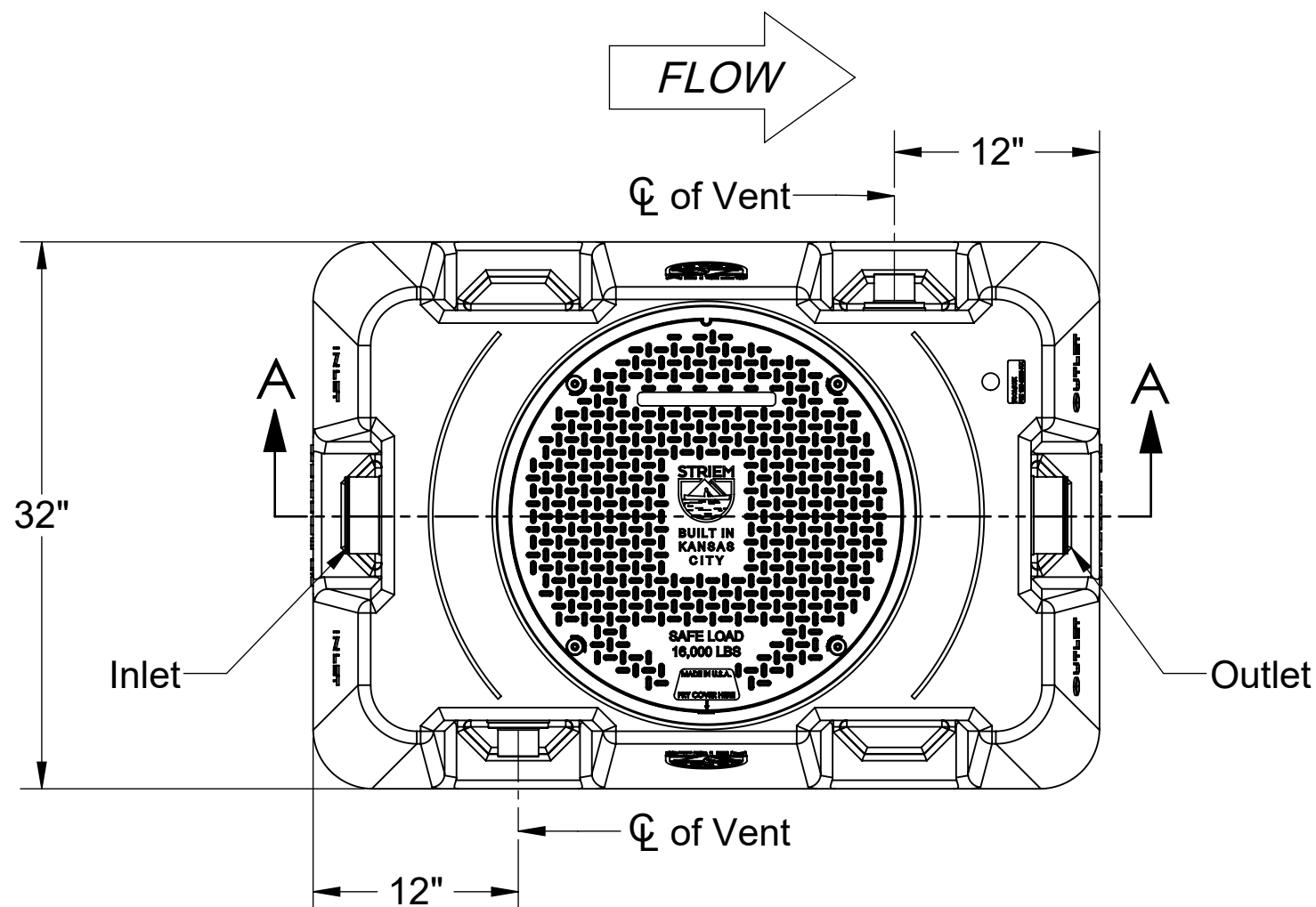

TOP VIEW

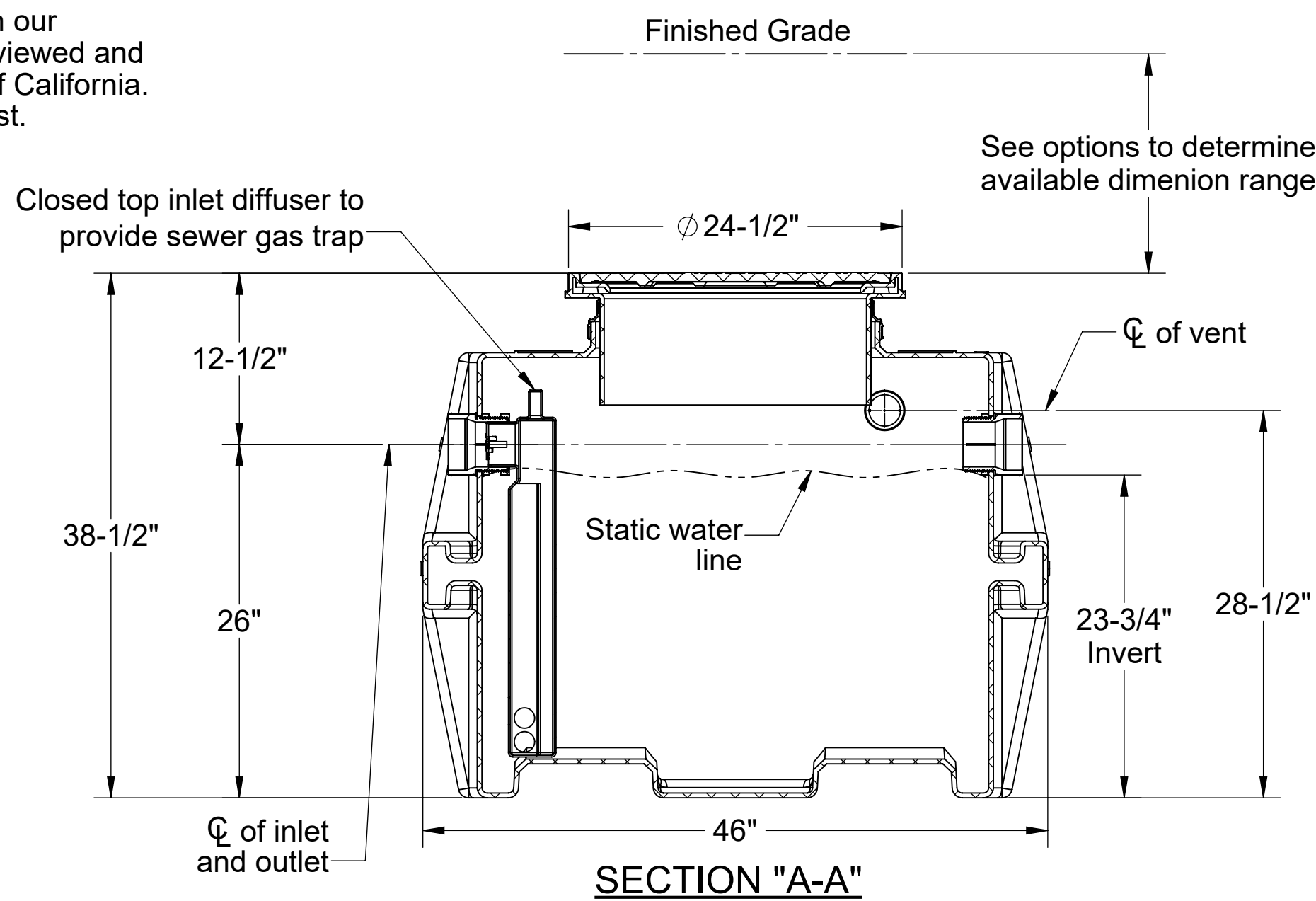
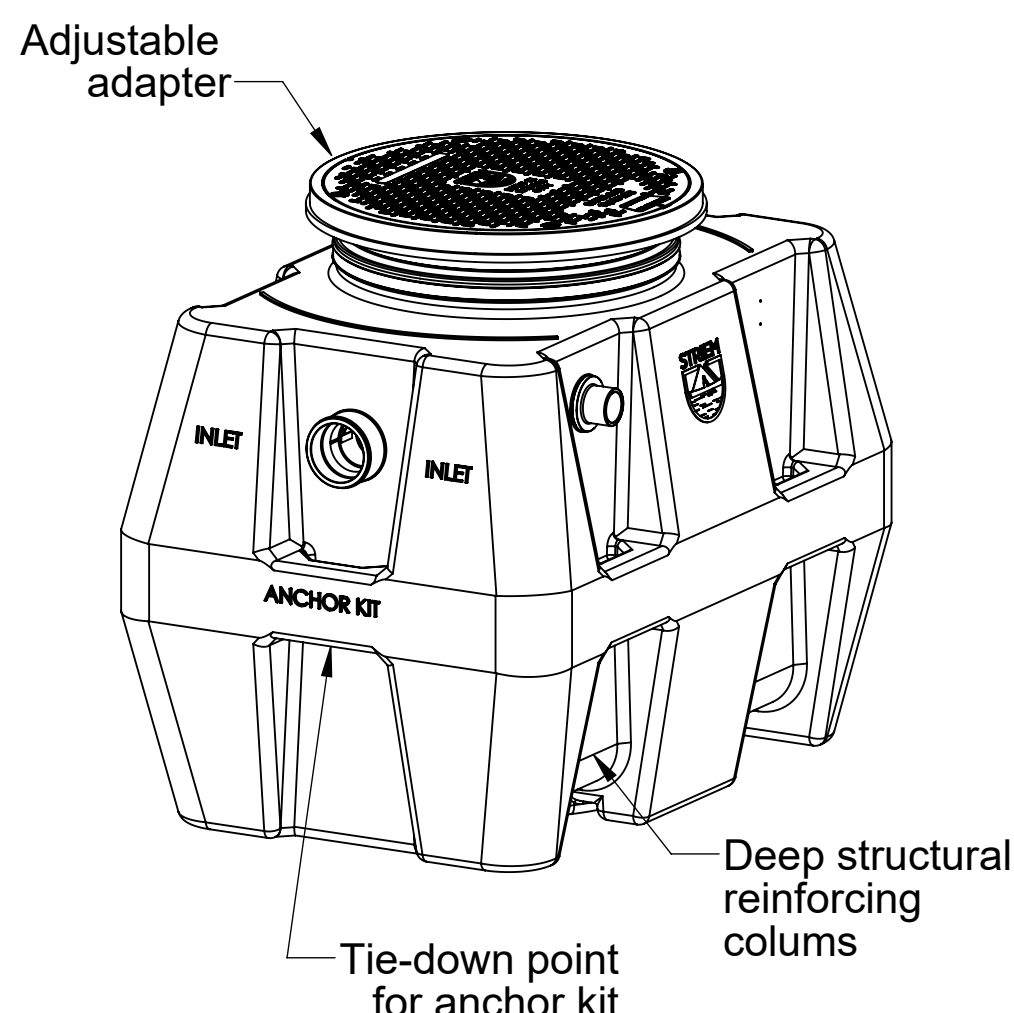

SECTION "A-A"

Directions: Complete steps 1-4 and submit signed with purchase order.

1. Choose Connection Types.

- | | |
|--|---|
| Inlet / Outlet | Size |
| <input type="checkbox"/> Plain End | <input type="checkbox"/> 3" |
| <input type="checkbox"/> Female Thread | <input type="checkbox"/> 4" |
| <input type="checkbox"/> Flanged | <input type="checkbox"/> 6" (Female Thread Not Available) |

- | | |
|-------------|-----------------------------|
| Vent | Size |
| Plain End | <input type="checkbox"/> 2" |
| | <input type="checkbox"/> 3" |

2. Diptube Location.

- Diptube at: Inlet Outlet Both (Ohio Code)
(Provided on inlet if not specified)

3. TeleGlide Riser Options.

- SR24 - >6"-24"
- LR24 - >24"-39"
- SR24 (2) - >39"-43"
- SR24 + LR24 - >43"-58"
- LR24 (2) - >58"-72"

4. Additional Options.

- CC-1 - Command Center pH Monitoring Package
 - SPK-A - Above Grade Sensor Placement Kit*
 - SPK-B - Below Grade Sensor Placement Kit*
- AK-1 - High Water Table Anchoring Kit
- 90%+ Calcium Carbonate Limestone (1,550 lbs.)

*Required with CC-1

Signature of Approval: _____
 Company: _____
 Date of Approval: _____
 Specifying Engineer: _____
 Engineering Firm: _____

PROPRIETARY AND CONFIDENTIAL

THE INFORMATION CONTAINED IN THIS DRAWING IS THE SOLE PROPERTY OF STRIEM, LLC. ANY REPRODUCTION IN PART OR AS A WHOLE WITHOUT THE WRITTEN PERMISSION OF STRIEM, LLC. IS PROHIBITED.

| | |
|--|----------------------|
| MODEL NUMBER: LB-125 | |
| DESCRIPTION: LAB BASIN SERIES POLYETHYLENE CHEMICAL WASTE TANK | |
| DWG BY: RS | DATE: 10/6/20 |
| REV: 02 | ECO: |

SPECIFICATION SHEET

Striem
 3100 Brinkerhoff
 Kansas City, KS 66115
 Tel: 913-222-1500
 Fax: 913-291-0457
 www.striemco.com

Made in the U.S.A

