

SPECIFICATIONS (LB-1500)

1. Liquid holding capacity: 1500 Gallons
2. Unit weight w/std. cover: 1,700 Pounds
3. 16,000 lb. load rated, bolted, gas/water tight composite covers.
4. Maximum operating temperature 140°F continuous.

NOTES

1. 1" thick high density polyethylene walls.
2. Unit supplied with built-in adapter(s) for up to 6" of adjustability. Additional riser(s) available for deeper burial depth.
3. Unit for below grade installation.
4. Lifting lug set included for easy install.

ENGINEER SPECIFICATION GUIDE

Striem Lab Basin™ neutralization tank model LB-1500 shall be lifetime guaranteed and Made in USA of High Density Polyethylene with minimum 1" uniform wall thickness. Tank shall be furnished with inlets, outlets, vents, cover, bracing, riser system, monitoring equipment and other modifications per jobsite-specific conditions and per engineer's specification.

THIRD PARTY STRUCTURAL ANALYSIS

The LB-1500 has been structurally analyzed in accordance with the requirements of IBC 2012 and ASCE/SEI 7 for direct burial. The maximum burial depth and backfill material are specified in our installation instructions. The structural design has been reviewed and sealed by a professional engineer registered in the state of California. A sealed structural analysis report is available upon request.

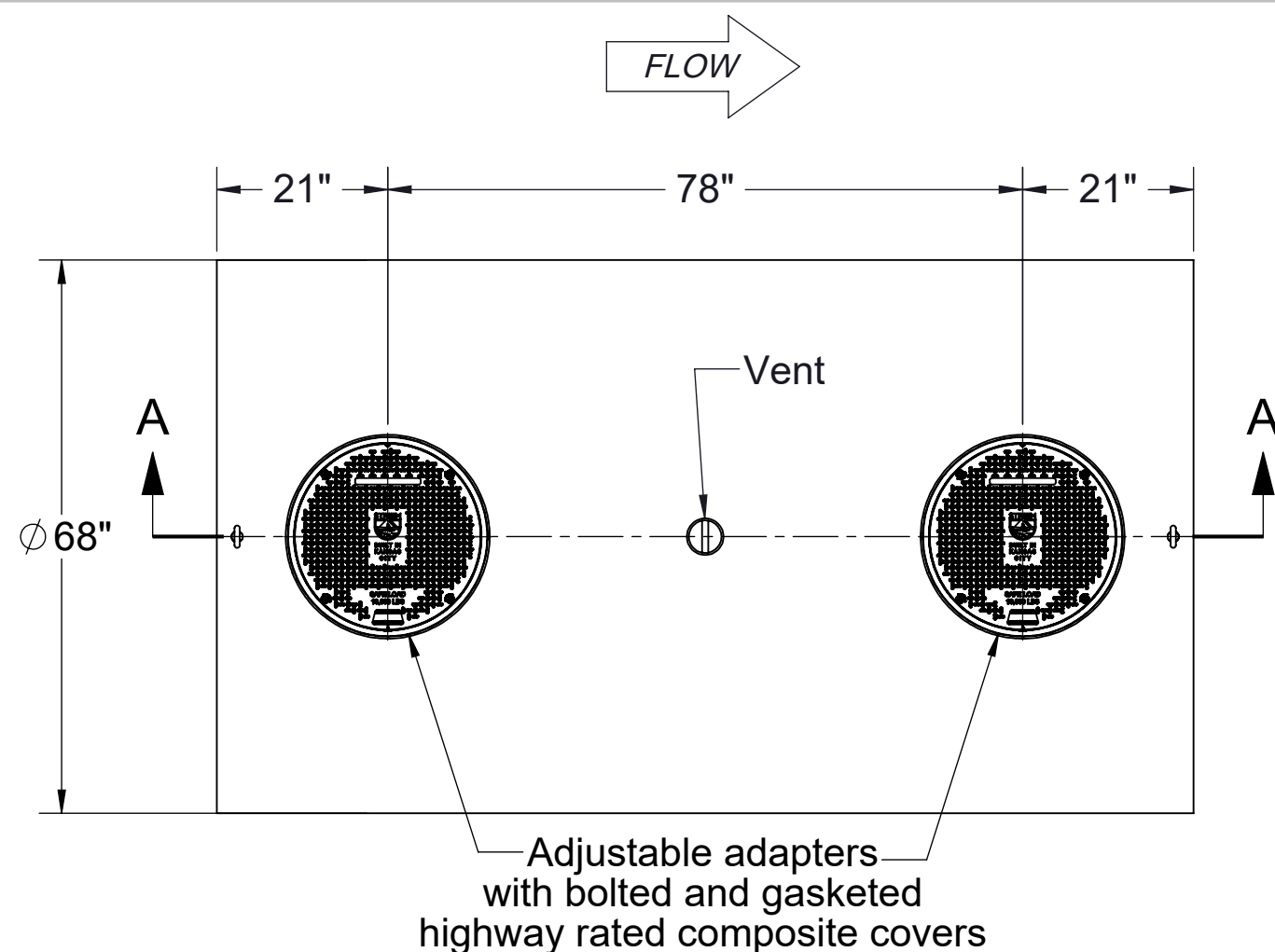
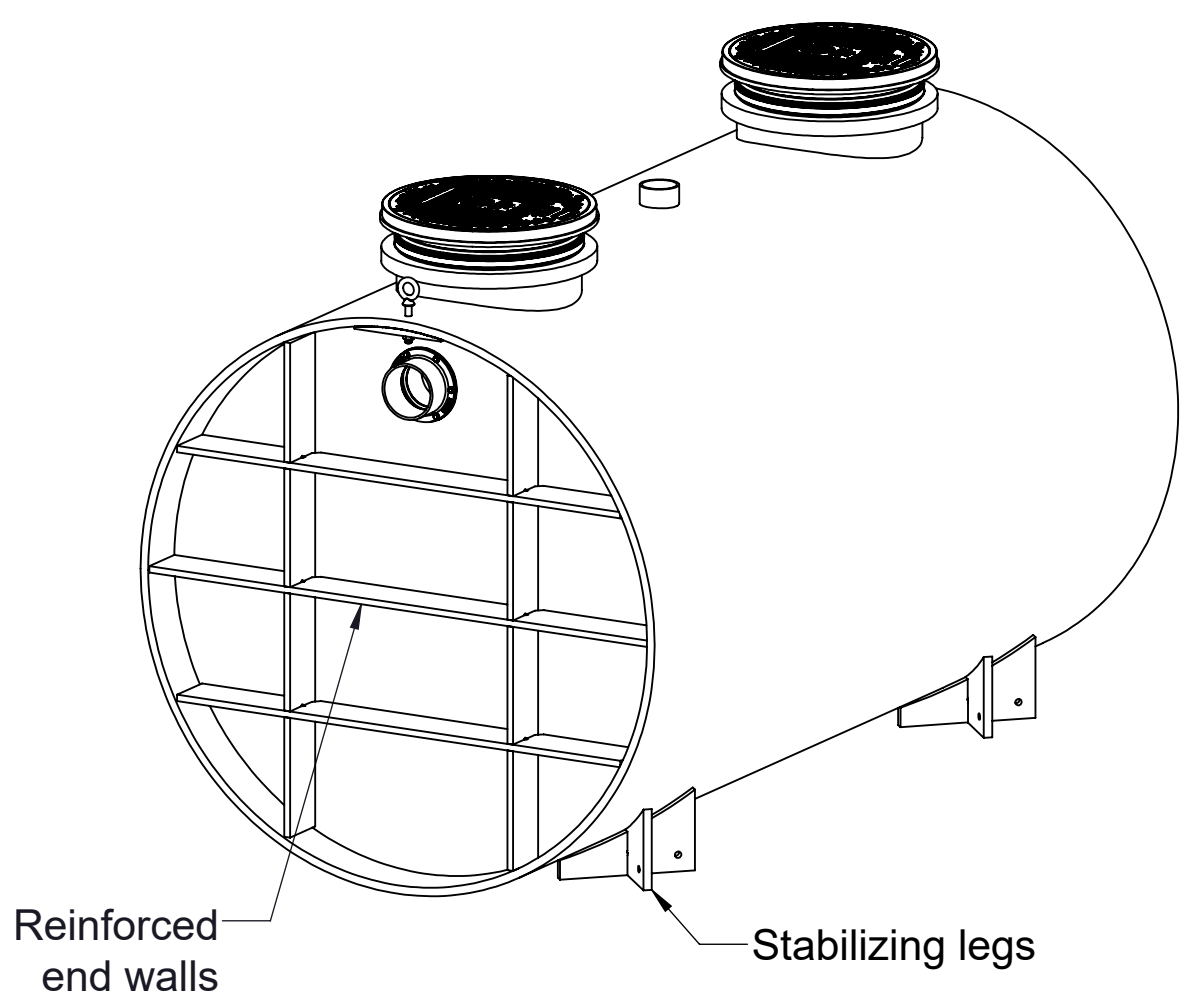

TOP VIEW

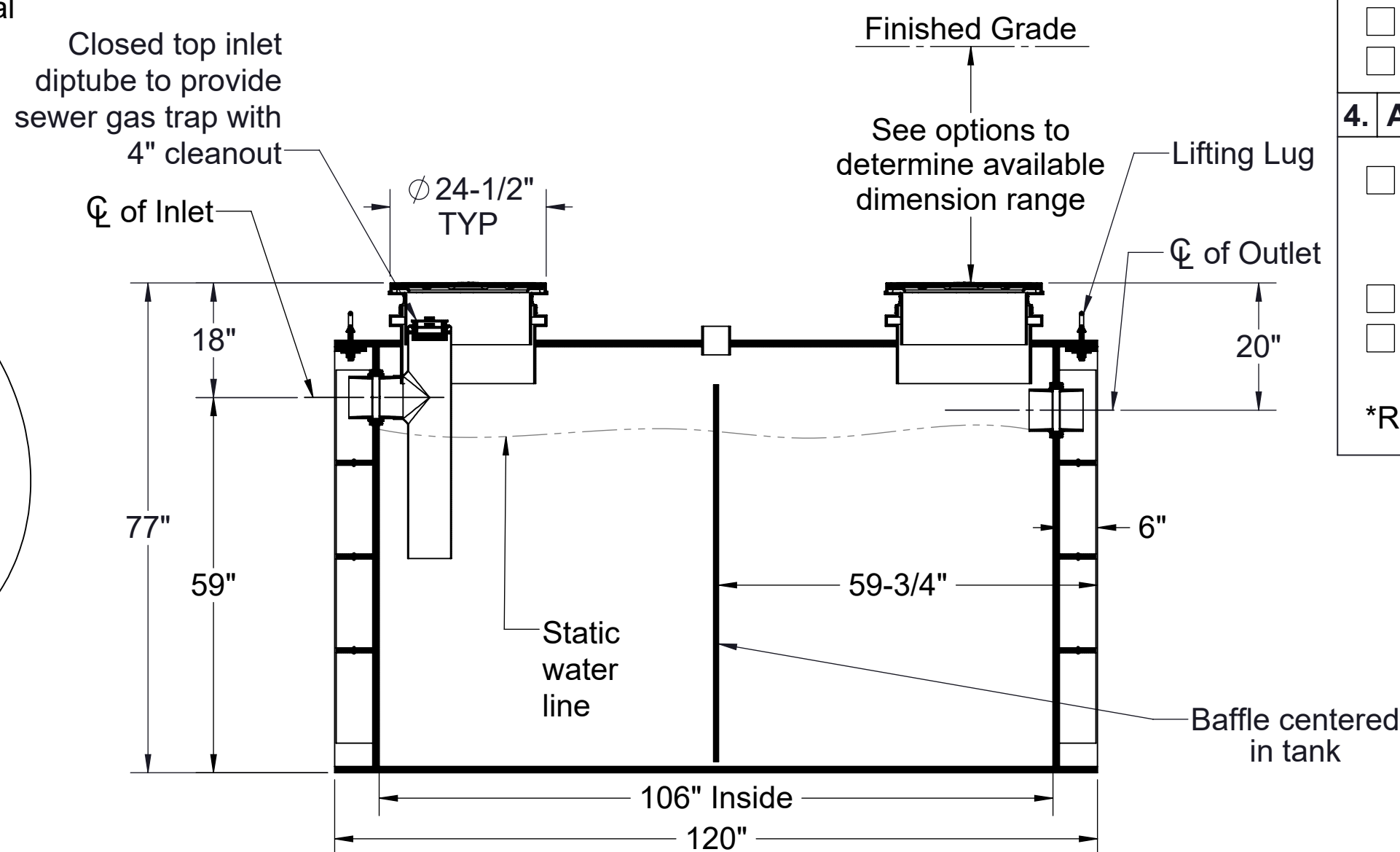

SECTION A-A

Directions: Complete steps 1-4 and submit signed with purchase order.

1. Choose Connection Types.

- | | |
|--|---|
| Inlet / Outlet | Size |
| <input type="checkbox"/> Plain End | <input type="checkbox"/> 4" |
| <input type="checkbox"/> Female Thread | <input type="checkbox"/> 6" (Female Thread Not Available) |
| <input type="checkbox"/> Flanged | <input type="checkbox"/> 8" (Only Plain End Available) |
| Vent | Size |
| <input type="checkbox"/> Plain End | <input type="checkbox"/> 2" |
| <input type="checkbox"/> Female Thread | <input type="checkbox"/> 3" |
| <input type="checkbox"/> Flanged | <input type="checkbox"/> 4" |

2. Diptube Location.

- Diptube at:** Inlet Outlet Both (Ohio Code)
(Provided on inlet if not specified)

3. TeleGlide Riser Options.

- SR24 (2) - >6"-24"
- LR24 (2) - >24"-39"
- SR24 (4) - >39"-43"
- SR24 (2) + LR24 (2) - >43"-58"
- LR24 (4) - >58"-72"

4. Additional Options.

- CC-1 - Command Center pH Monitoring Package
 - SPK-A - Above Grade Sensor Placement Kit*
 - SPK-B - Below Grade Sensor Placement Kit*
- HDK-1 - High Water Table Hold Down Kit
- 90%+ Calcium Carbonate Limestone (19,500 lbs.)

*Required with CC-1

Signature of Approval: _____
 Company: _____
 Date of Approval: _____
 Specifying Engineer: _____
 Engineering Firm: _____

PO IS NON-CANCELABLE
 ORDER IS NON-RETURNABLE

MODEL NUMBER: LB-1500	
DESCRIPTION: POLYETHYLENE NEUTRALIZATION TANK 1500 GALLON CAPACITY	
DWG BY: MJ	DATE: 04/23/2020
REV: 0	ECO:

SPECIFICATION SHEET

Striem
 3100 Brinkerhoff
 Kansas City, KS 66115
 Tel: 913-222-1500
 Fax: 913-291-0457
 www.striemco.com



Made in the U.S.A

PROPRIETARY AND CONFIDENTIAL
 THE INFORMATION CONTAINED IN THIS DRAWING IS THE SOLE PROPERTY OF STRIEM, LLC.
 ANY REPRODUCTION IN PART OR AS A WHOLE WITHOUT THE WRITTEN PERMISSION OF STRIEM, LLC. IS PROHIBITED.