

SPECIFICATIONS

1. 3" Plain End inlet/outlets.
2. Max flow rate: 50 GPM.
3. Liquids Capacity with high outlet: 38 gal.
4. Liquids Capacity with low outlet: 12 gal.
5. Solids Capacity: 6 gal.
6. Screen Perforations: 1/8" diameter.
7. Unit weight w/std. covers: 83 lbs.
8. Composite cover: 2,000 lbs. capacity.
9. Maximum operating temperature 140°F continuous.

NOTES

1. Seamless medium density polyethylene 3/8" wall tank.
2. Cover placement allows full access to tank for proper maintenance.
3. For on the-floor or buried applications.

INNOVATIONS

1. **Removable basket interlocks with inlet:** prevents solids from escaping basket.
2. **UNI-FIT™:** basket inserts in one orientation.
3. **All-perforated basket:** basket perforations are more than 24 times inlet opening, creating easy flow in the presence of solids, and limiting the chance for a backup.
4. **Optional low outlet:** if used, it allows for a temporary water surge (acts as a reservoir), as well as keeps basket dry during maintenance.
5. **Movable trap:** sewer gas trap can be field-installed on high or low outlet.

ENGINEER SPECIFICATION GUIDE

Striem Aardvark™ solids interceptor model AA-M shall be lifetime guaranteed and made in the USA. Tank material shall be polyethylene. Interceptor shall have removable, corrosion-resistant filter basket. Interceptor shall be equipped with high and low outlet options, with a movable sewer gas trap to be located on either outlet. Interceptor shall be furnished for above- or below-grade installation. Cover shall be water and gas tight with a minimum 2,000 lbs load capacity. Interceptor shall be certified to IAPMO IGC 167-2011ae2.

OPTIONS

- 3M** - 3" Male Thread Connections
- 4P** - 4" Plain End SCH.40 Connections*
- 4M** - 4" Male Thread Connections*
- CC24** - Integral Membrane Clamping Collar Kit

* Optional sewer gas trap not compatible with low outlet if 4" connections are selected.

TeleGlide RISER OPTIONS

Included: 0" - 2"

- SR24:** 5" - 24"
- LR24:** 24" - 39"

*If in the range of 2"-5", contact Striem for a custom solution.

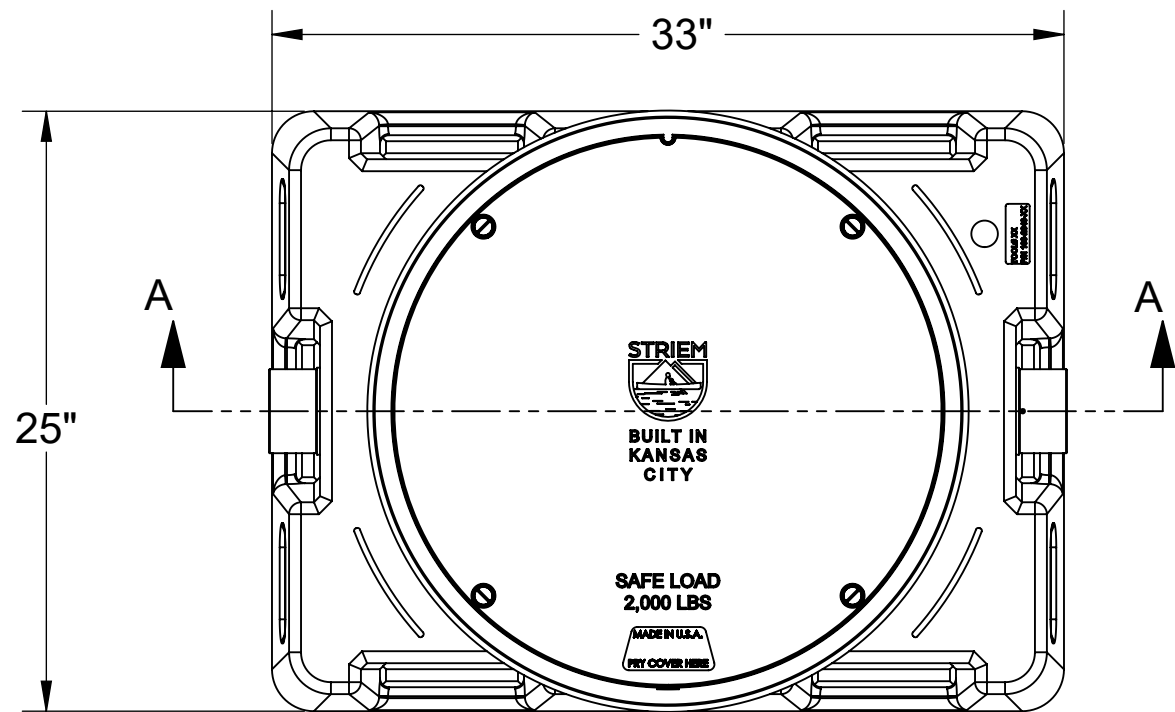

TOP VIEW

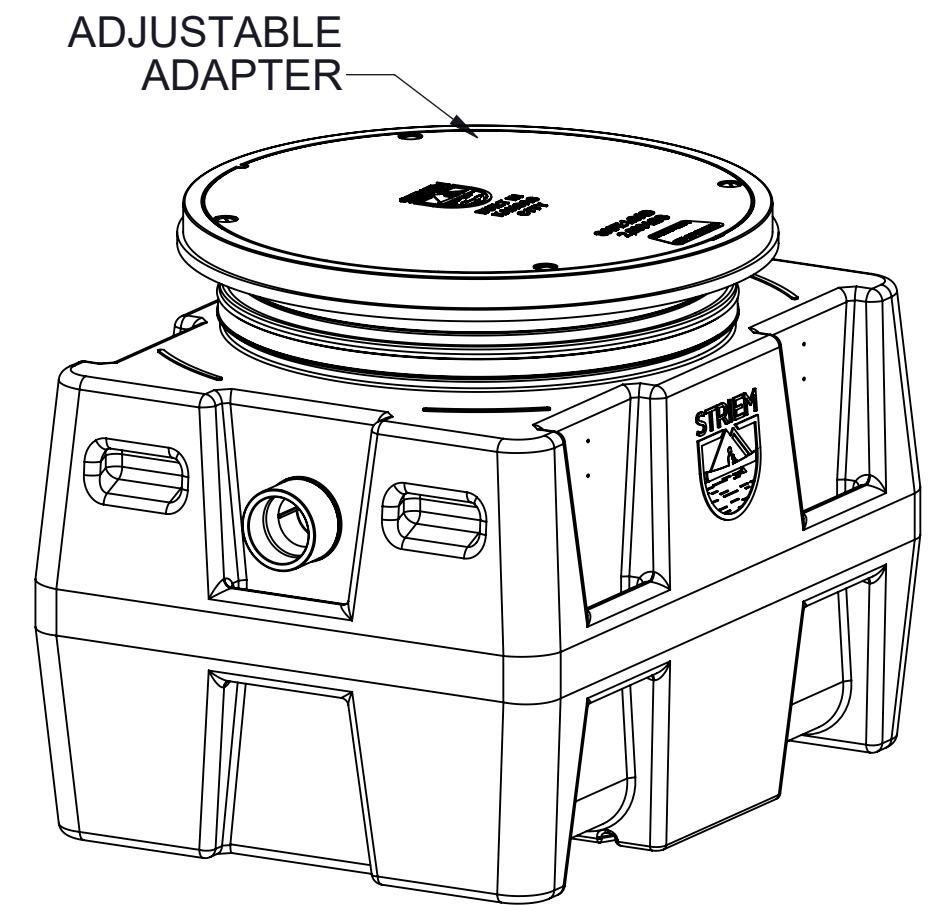

ISOMETRIC VIEW

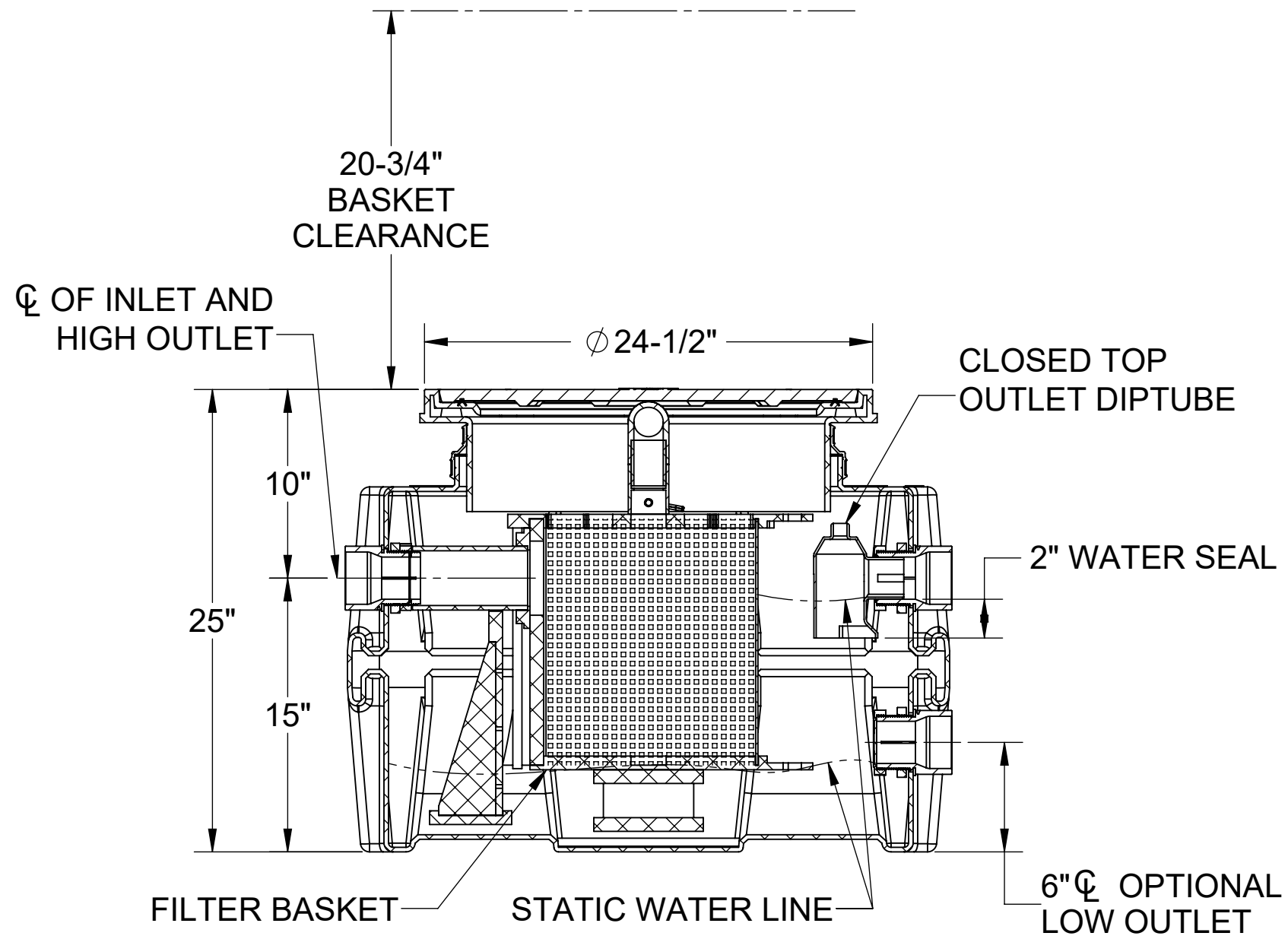

SECTION "A-A"

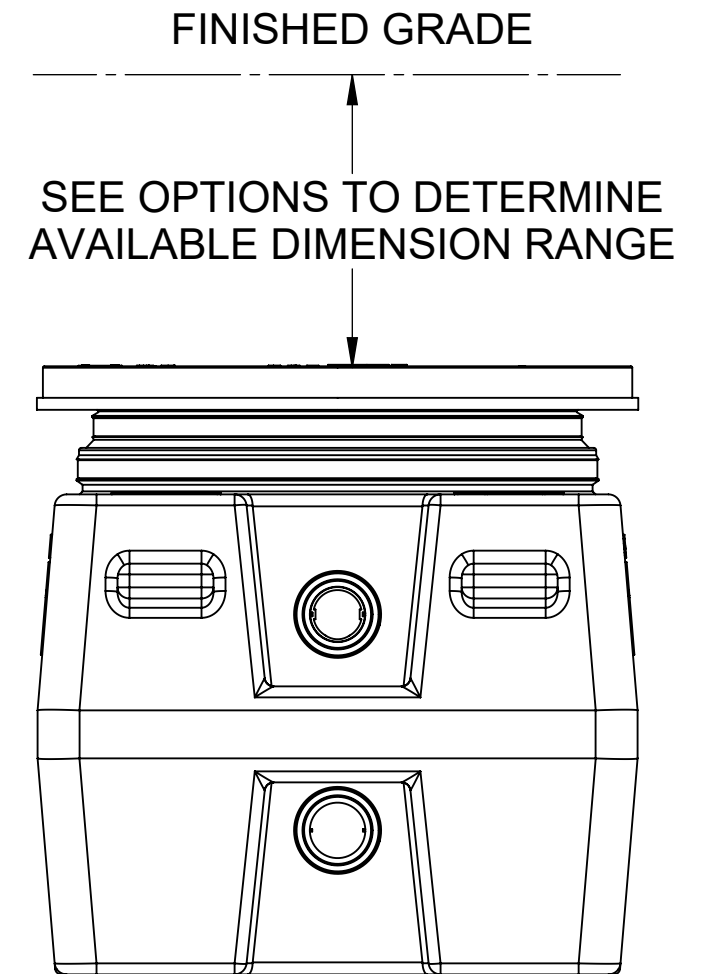

OUTLET END VIEW

Signature of Approval: _____
 Company: _____
 Date of Approval: _____
 Specifying Engineer: _____
 Engineering Firm: _____

US Patent No.
US10786761B2

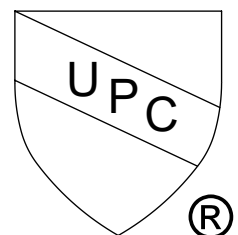

PROPRIETARY AND CONFIDENTIAL

THE INFORMATION CONTAINED IN THIS DRAWING IS THE SOLE PROPERTY OF STRIEM, LLC. ANY REPRODUCTION IN PART OR AS A WHOLE WITHOUT THE WRITTEN PERMISSION OF STRIEM, LLC. IS PROHIBITED.

MODEL NUMBER: AA-M	
DESCRIPTION: AARDVARK™ MEDIUM BASKET-STYLE SOLIDS INTERCEPTOR	
DWG BY: MJ	DATE: 04/13/2022
REV: 0	ECO:

SPECIFICATION SHEET

Striem
 3100 Brinkerhoff
 Kansas City, KS 66115
 Tel: 913-222-1500
 orders@striemco.com
 www.striemco.com

Made in the U.S.A