

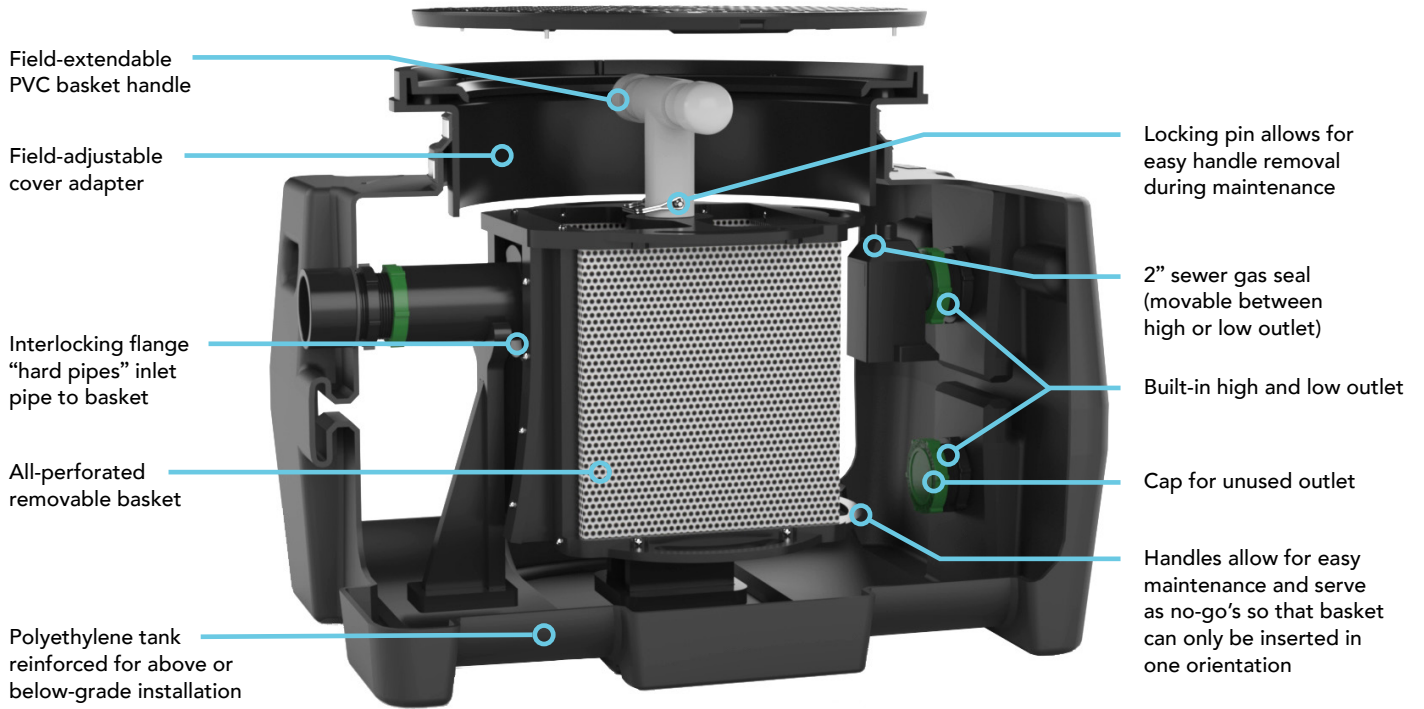

AARDVARK™ SERIES

BASKET-STYLE SOLIDS INTERCEPTORS



(AA-M shown)

CHECK OUT OUR
**ONLINE LINT
INTERCEPTOR
SIZING TOOL.**



List by IAPMO to
IGC 167-2011ae2

Pat No. 10,786,761

APPLICATIONS



LAUNDRY
FACILITIES



COMMERCIAL
KITCHENS



DOG WASH &
PET KENNELS



ART ROOM
SINKS



BARBER SHOPS &
HAIR SALONS



FOOD
PROCESSING



913-222-1500 HELP@STRIEMCO.COM
STRIEMCO.COM





AARDVARK™ SERIES

BASKET-STYLE SOLIDS INTERCEPTORS



AA-S SMALL

CONNECTIONS: 2" PLAIN END
LIQUID CAPACITY: 16 GAL.
(HIGH OUTLET), 4 GAL. (LOW OUTLET)
SOLIDS CAPACITY: 2 GAL.
WEIGHT: 42 LBS.

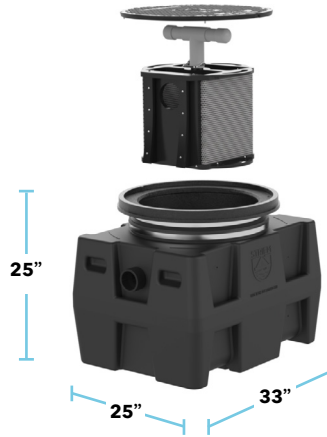

AA-M MEDIUM

CONNECTIONS: 3" PLAIN END
LIQUID CAPACITY: 38 GAL.
(HIGH OUTLET), 12 GAL. (LOW OUTLET)
SOLIDS CAPACITY: 6 GAL.
WEIGHT: 83 LBS.



AA-L LARGE

CONNECTIONS: 4" PLAIN END
LIQUID CAPACITY: 57 GAL.
(HIGH OUTLET), 14 GAL. (LOW OUTLET)
SOLIDS CAPACITY: 8 GAL.
WEIGHT: 105 LBS.



AA-XL EXTRA LARGE

CONNECTIONS: 4" PLAIN END,
6" OPTIONAL
LIQUID CAPACITY: 110 GAL.
(HIGH OUTLET), 30 GAL. (LOW OUTLET)
SOLIDS CAPACITY: 10 GAL.
WEIGHT: 143 LBS.

OPTIONS

- Field-adjustable extensions
- High water anchor kits (AA-L and AA-XL only)
- Clamping collars

SPEC FORMATS



AVAILABLE ONLINE FOR ALL PRODUCTS



913-222-1500 HELP@STRIEMCO.COM
STRIEMCO.COM

