

**SPECIFICATIONS**

1. 6" Plain End inlet shown, 3" Plain End vents standard.
2. Liquid holding capacity: 1000 gallons (133 cu. ft.).
3. Unit weight: 1184 lbs.
4. Maximum operating temperature 140°F continuous.

**NOTES**

1. For gravity drainage applications only.
2. Do not use for pressure applications.
3. Cover placement allows full access to tank for proper maintenance.
4. Lifting lug set for easy install.

**ENGINEER SPECIFICATION GUIDE**

Striem decontamination tank model BB-1000 shall be lifetime guaranteed and made in the USA. Tank shall be constructed of polyethylene with 7/8" nominal wall thickness. Tank shall be manufactured for below-grade installation. Field-adjustable riser system is available as an option to bring manhole covers to grade. Tank liquid holding capacity shall be 1000 gallons. Covers shall provide water/gas-tight seal and have a maximum 16,000 lbs. load capacity.

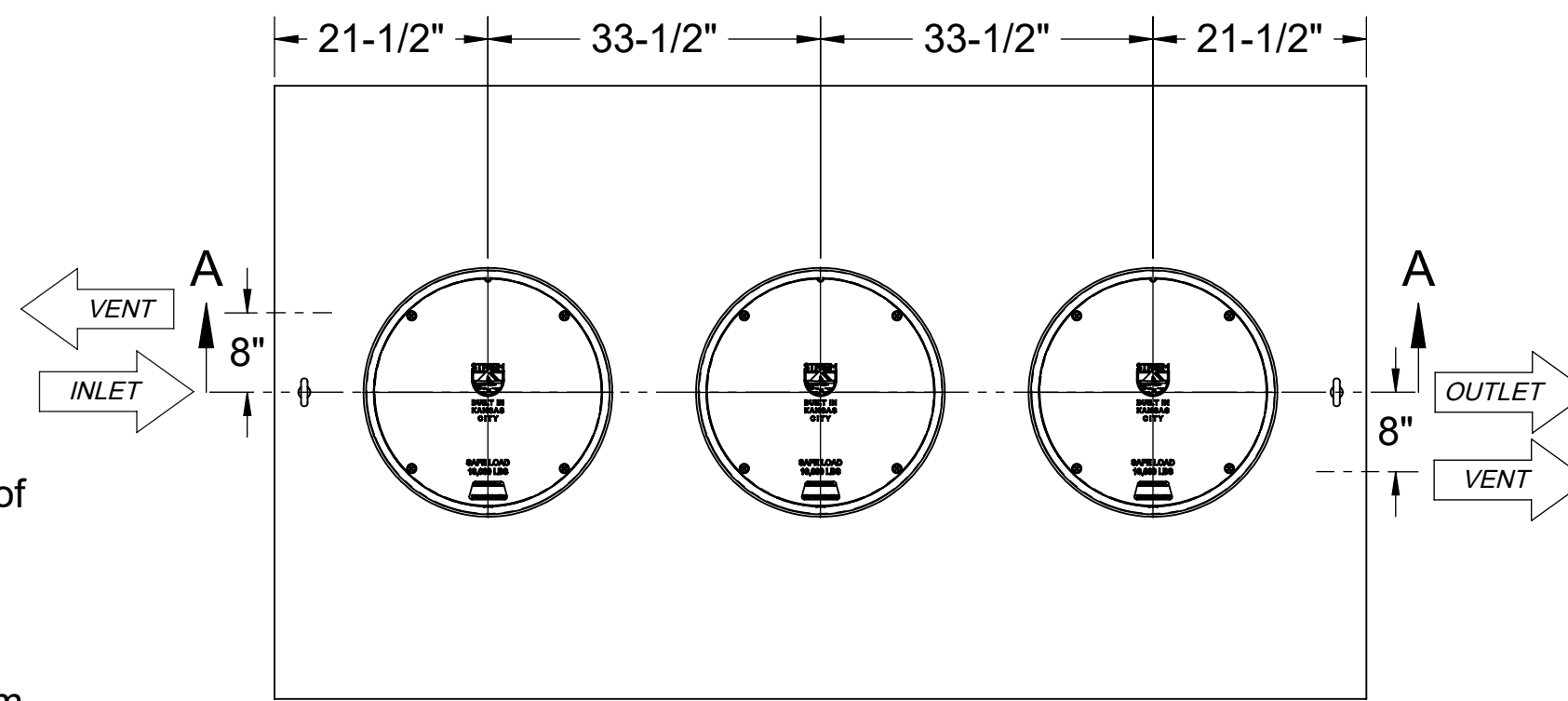

**TOP VIEW**

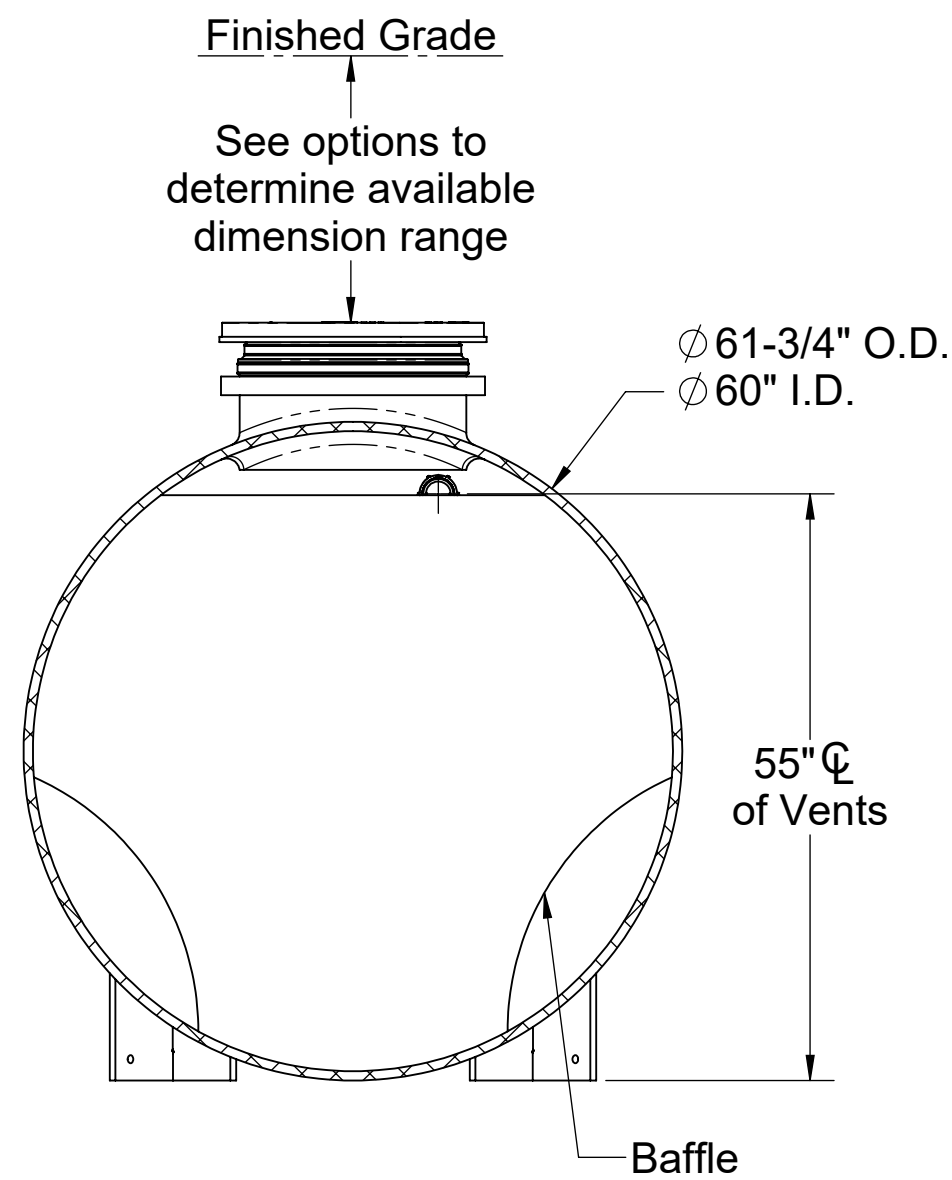

**SECTION B-B**

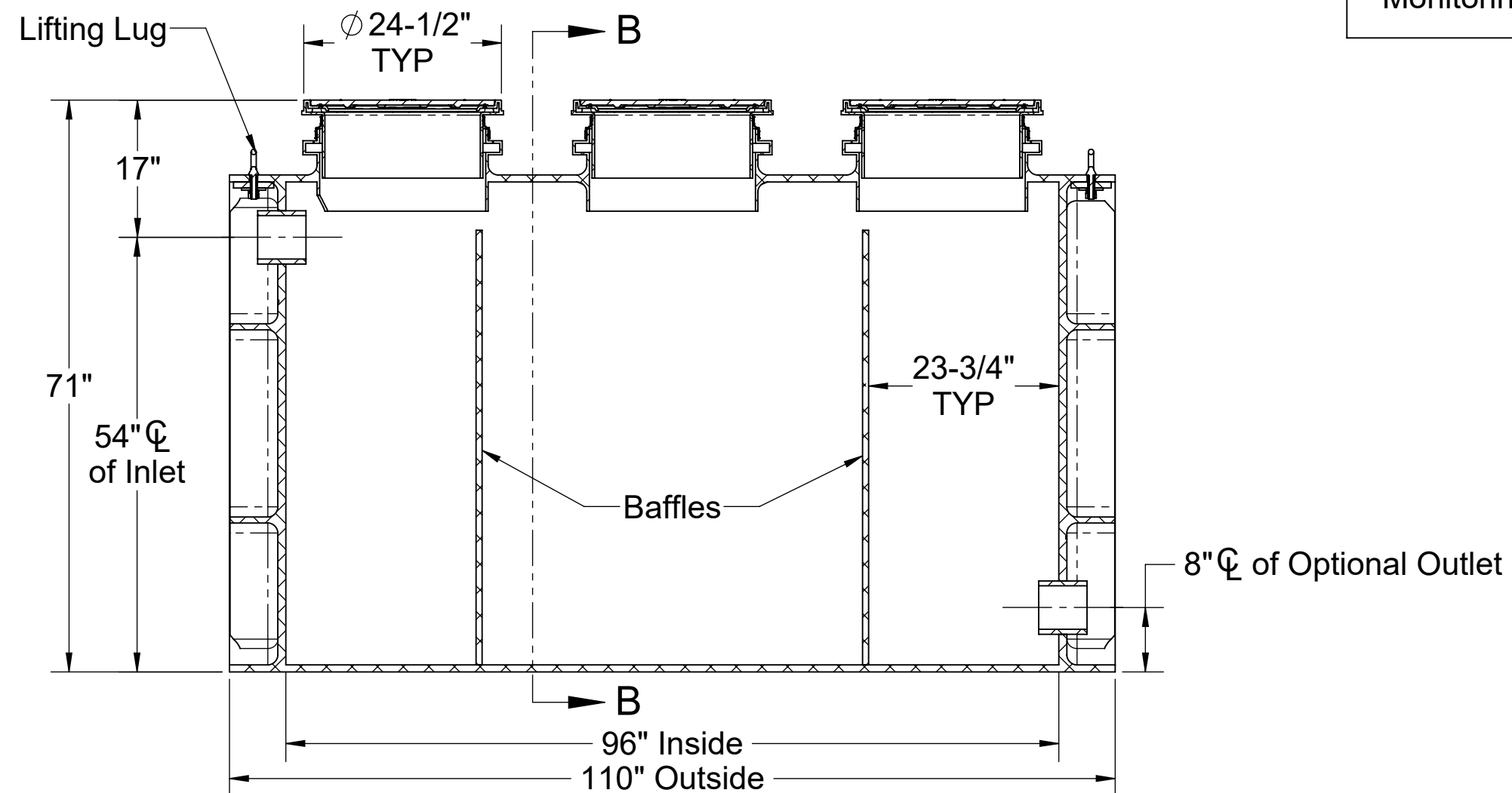

**SECTION A-A**

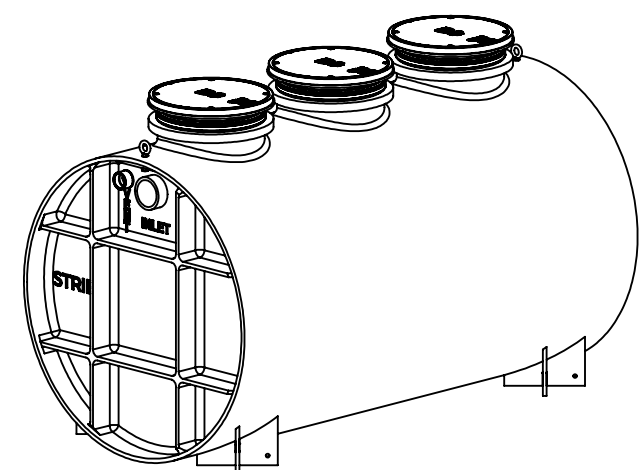

PO IS NON-CANCELABLE  
ORDER IS NON-RETURNABLE

PROPRIETARY AND CONFIDENTIAL  
THE INFORMATION CONTAINED IN THIS DRAWING IS THE SOLE PROPERTY OF STRIEM, LLC.  
ANY REPRODUCTION IN PART OR AS A WHOLE WITHOUT THE WRITTEN PERMISSION OF STRIEM, LLC. IS PROHIBITED.

**OPTIONS**

**Connection Options (Plain End Only)**

Inlet	Optional Outlet	SELECTION REQUIRED
<input type="checkbox"/> 3"	<input type="checkbox"/> 3"	
<input type="checkbox"/> 4"	<input type="checkbox"/> 4"	
<input type="checkbox"/> 6"	<input type="checkbox"/> 6"	

**Riser Options**

**From Factory: 0" - 5"**

- Up to 24": **SR24** (3)
- Up to 39": **LR24** (3)
- Up to 43": **SR24** (6)
- Up to 58": **SR24** (3) + **LR24** (3)
- Up to 72": **LR24** (6)
- Up to 90": **SR24** (3) + **LR24** (6)
- Up to 106": **LR24** (9)

- OR -

- CPRK** (3): 11" - 106" (See specification for more detail.)

**Additional Options**

- HDK-5**: High Water Table Hold Down Kit
- AVA-3**: Single-Level Monitoring Package \*
- AVA-4**: Multi-Level Monitoring Package \*

\*Monitoring packages will raise covers by 3".

**MODEL NUMBER:** BB-1000

**DESCRIPTION:**  
BIO BASIN™  
POLYETHYLENE DECONTAMINATION TANK  
1000 GALLON CAPACITY

**DWG BY:** ENG    **DATE:** 8/22/2023    **REV:** 1

**SPECIFICATION SHEET**

Striem  
Kansas City, KS  
Tel: 913-222-1500  
orders@striemco.com  
www.striemco.com

Made in the U.S.A

