

**SPECIFICATIONS**

1. Liquid holding capacity: 500 gallons (66.7 cu. ft.).
2. Unit weight with composite cover: 750 lbs.
3. Maximum operating temperature 140°F continuous.
4. Highway rated cover: 16,000 lb. load rating.

**NOTES**

1. For gravity drainage applications only. Do not use for pressure applications.
2. 7/8" thick seamless High Density Polyethylene.
3. Unit supplied with built-in adapter for up to 5" of adjustability. Additional riser(s) available for deeper burial depth.
4. Cover placement allows full access to tank for proper maintenance.
5. For buried applications.
6. Lifting lug set for easy install.

**ENGINEER SPECIFICATION GUIDE**

Striem Bio Basin model BB-500 shall be lifetime guaranteed and made in USA of seamless, molded High Density Polyethylene with minimum 7/8" uniform wall thickness. Tank shall be furnished for below grade installation with field adjustable riser system. Cover shall provide water/gas-tight seal and have a maximum 16,000 lbs load rating.

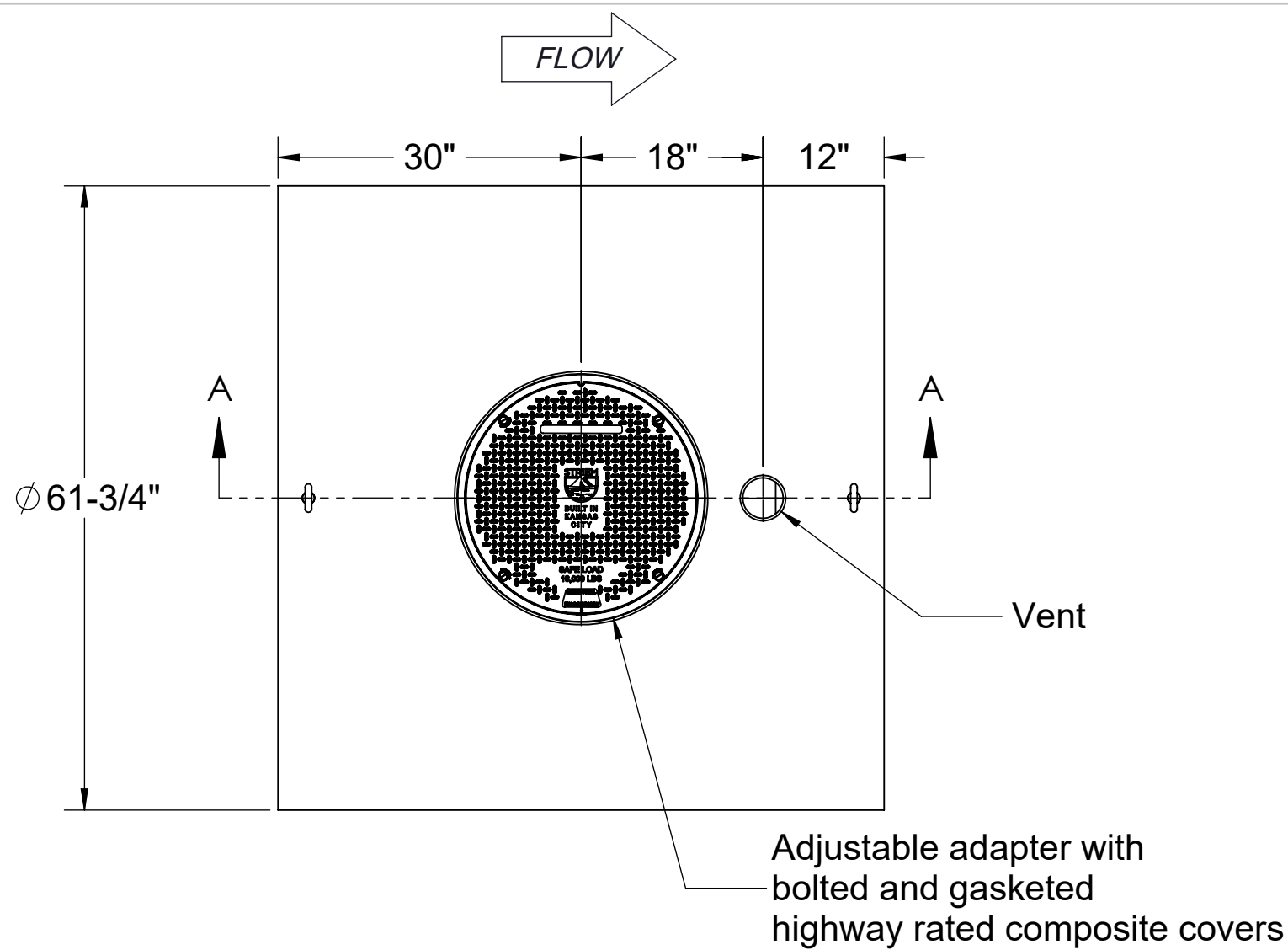
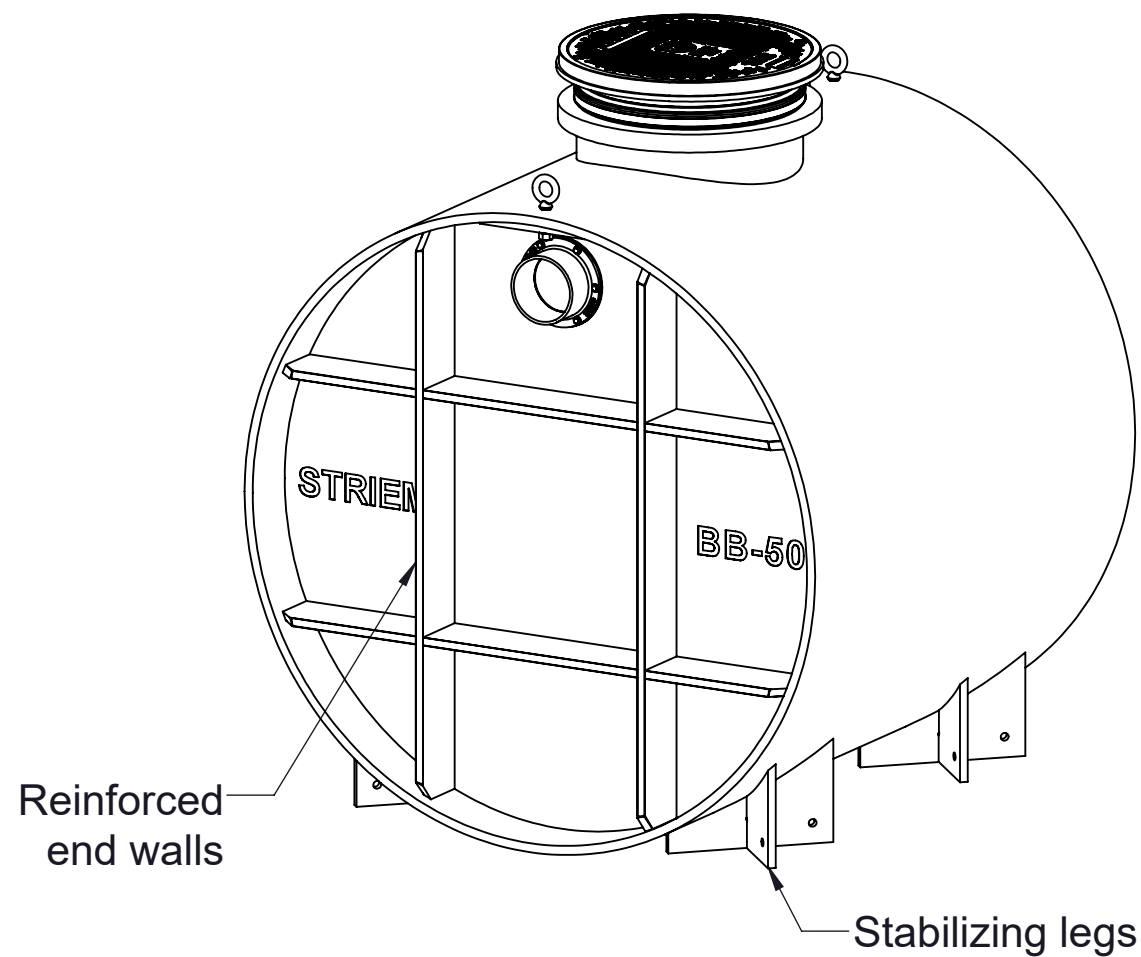

**TOP VIEW**

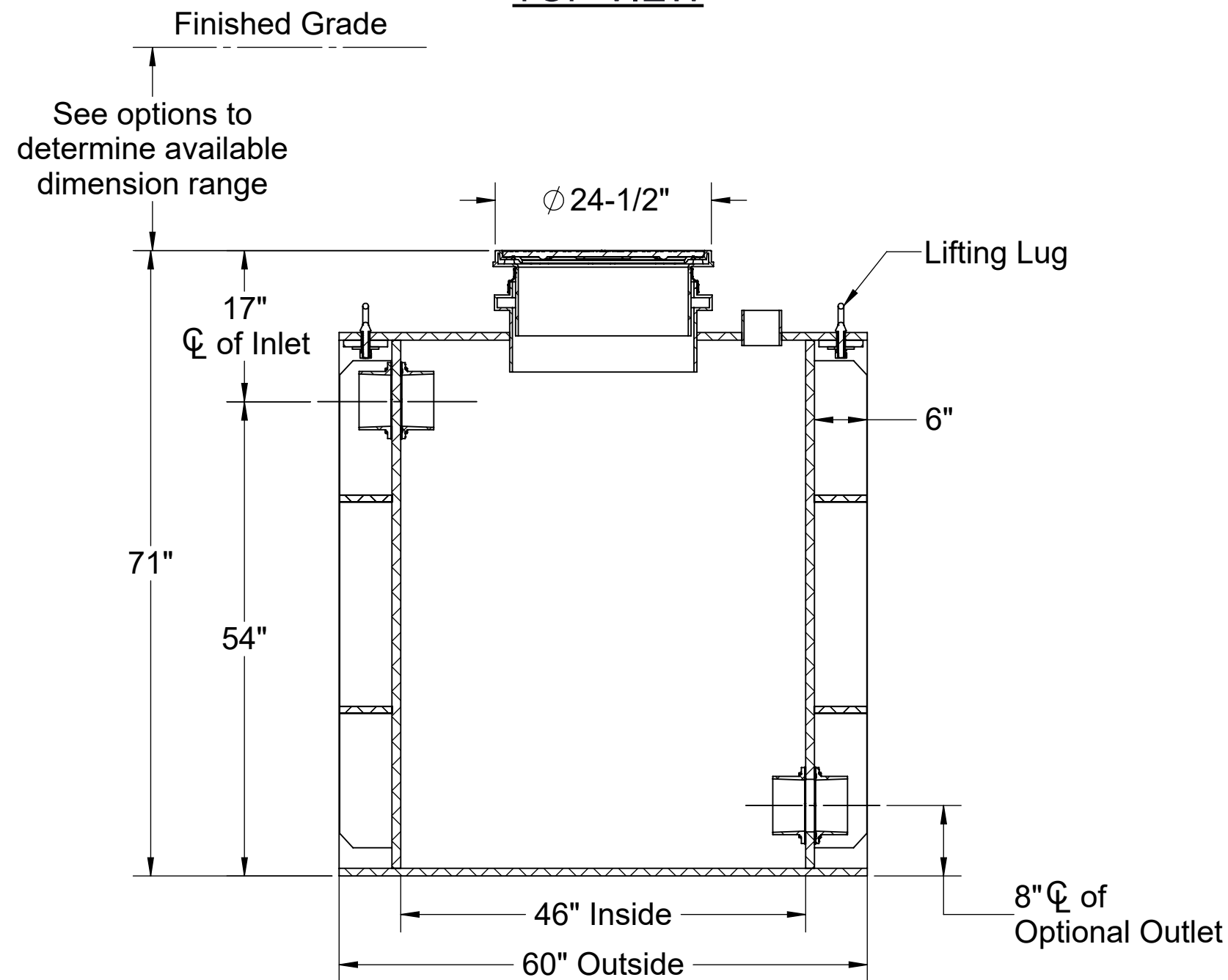

**SECTION A-A**

**Directions: Complete steps 1-3 and submit signed with purchase order.**

**1. Choose Connection Types.**

- |  |  |
|--|--|
| <b>Inlet</b>                           | <b>Size</b>  |
| <input type="checkbox"/> Plain End     | <input type="checkbox"/> 2"                        |
| <input type="checkbox"/> Female Thread | <input type="checkbox"/> 3"                        |
| <input type="checkbox"/> Flanged       | <input type="checkbox"/> 4"                        |
|  | <input type="checkbox"/> 6" (female not available) |
| <b>Optional Outlet</b>                 | <b>Size</b>  |
| <input type="checkbox"/> Plain End     | <input type="checkbox"/> 2"                        |
| <input type="checkbox"/> Female Thread | <input type="checkbox"/> 3"                        |
| <input type="checkbox"/> Flanged       | <input type="checkbox"/> 4"                        |
|  | <input type="checkbox"/> 6" (female not available) |
| <b>Vent</b>                            | <b>Size</b>  |
| <input type="checkbox"/> Plain End     | <input type="checkbox"/> 2"                        |
| <input type="checkbox"/> Female Thread | <input type="checkbox"/> 3"                        |
| <input type="checkbox"/> Flanged       | <input type="checkbox"/> 4"                        |

**2. Riser Options.**

- Included : 0" - 5"**
- SR24** : >5" - 24"
  - LR24** : >24" - 39"
  - SR24 (2)** : >39" - 43"
  - SR24 + LR24** : >43" - 58"
  - LR24 (2)** : >58" - 72"
  - SR24 + LR24 (2)** : >72" - 90"
  - LR24 (3)** : >90" - 106"
- OR -**
- CPRK** : >11" - 106"
    - Corrugated Pipe Riser Kit.
    - Used in substitute of SR/LR riser options.
    - 18" diameter corrugated pipe by others.
    - See CPRK specification for more detail.

**3. Choose Additional Options.**

- HDK-CWT-500** - High Water Table Hold Down Kit
- AVA-3** - Single Level Monitoring Package \*
- AVA-4** - Multi-Level Monitoring Package \*
- Outlet with manual valve (see drawing on sheet 2)
- Outlet with electronically actuated valve controlled by monitoring package (see drawing on sheet 3)

\*Monitoring packages will raise covers by 3".

**SHEET 1**

Signature of Approval: \_\_\_\_\_  
 Company: \_\_\_\_\_  
 Date of Approval: \_\_\_\_\_  
 Specifying Engineer: \_\_\_\_\_  
 Engineering Firm: \_\_\_\_\_

PO IS NON-CANCELABLE  
 ORDER IS NON-RETURNABLE

<b>MODEL NUMBER:</b>	BB-500
<b>DESCRIPTION:</b>	POLYETHYLENE DECONTAMINATION TANK 500 GALLON CAPACITY
<b>DWG BY:</b>	WLF
<b>DATE:</b>	4/23/21
<b>REV:</b>	0
<b>ECO:</b>	

**SPECIFICATION SHEET**

**Striem**  
 3100 Brinkerhoff  
 Kansas City, KS 66115  
 Tel: 913-222-1500  
 orders@striemco.com  
 www.striemco.com



Made in the U.S.A

THE INFORMATION CONTAINED IN THIS DRAWING IS THE SOLE PROPERTY OF STRIEM, LLC. ANY REPRODUCTION IN PART OR AS A WHOLE WITHOUT THE WRITTEN PERMISSION OF STRIEM, LLC. IS PROHIBITED.

**SPECIFICATIONS**

1. Liquid holding capacity: 500 gallons (66.7 cu. ft.).
2. Unit weight with composite cover: 750 lbs.
3. Maximum operating temperature 140°F continuous.
4. Highway rated cover: 16,000 lb. load rating.

**NOTES**

1. For gravity drainage applications only. Do not use for pressure applications.
2. 7/8" thick seamless High Density Polyethylene.
3. Unit supplied with built-in adapter for up to 5" of adjustability. Additional riser(s) available for deeper burial depth.
4. Cover placement allows full access to tank for proper maintenance.
5. For buried applications.
6. Lifting lug set for easy install.

**ENGINEER SPECIFICATION GUIDE**

Striem Bio Basin model BB-500 shall be lifetime guaranteed and made in USA of seamless, molded High Density Polyethylene with minimum 7/8" uniform wall thickness. Tank shall be furnished for below grade installation with field adjustable riser system. Cover shall provide water/gas-tight seal and have a maximum 16,000 lbs load rating.

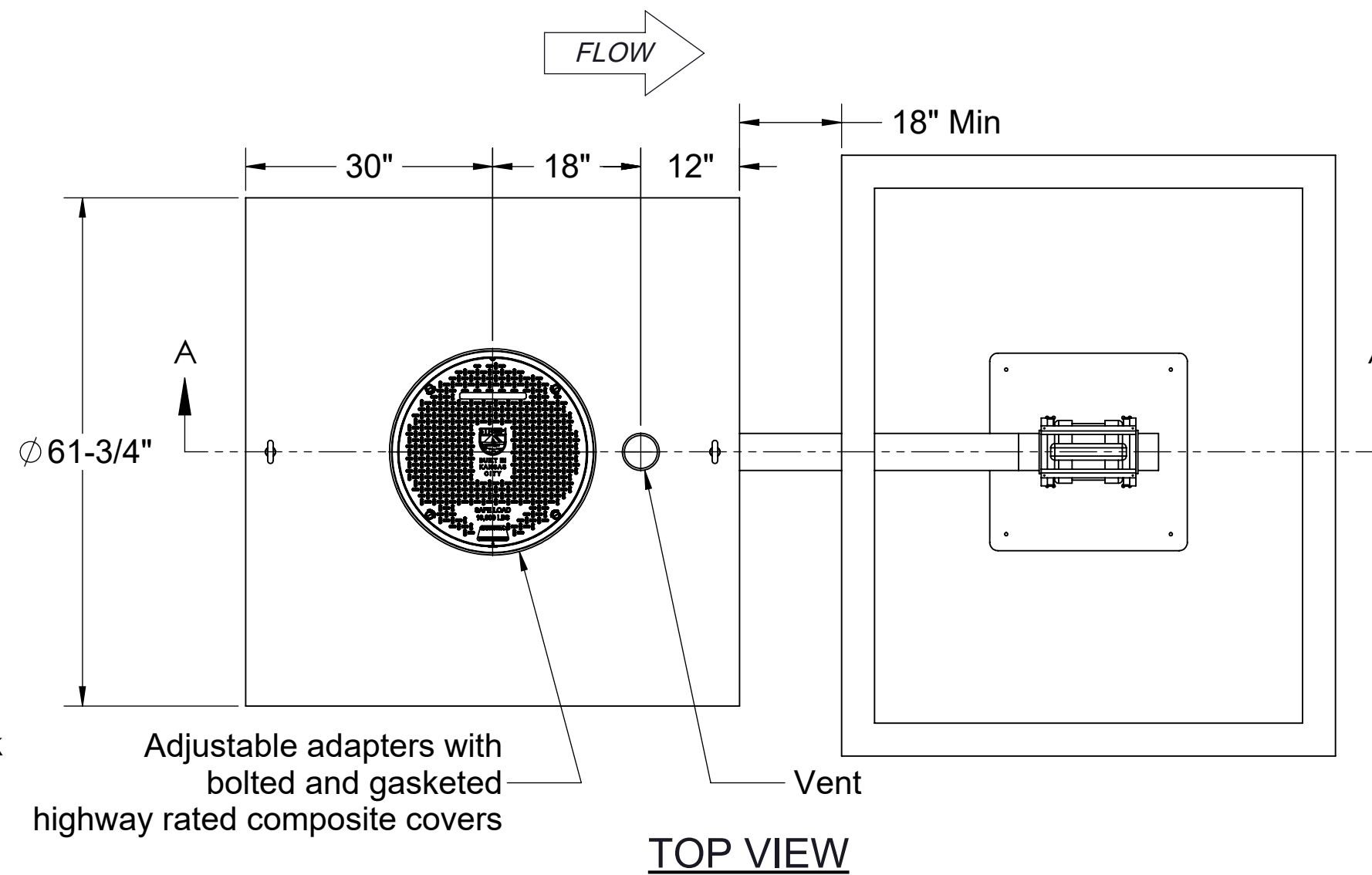

**TOP VIEW**

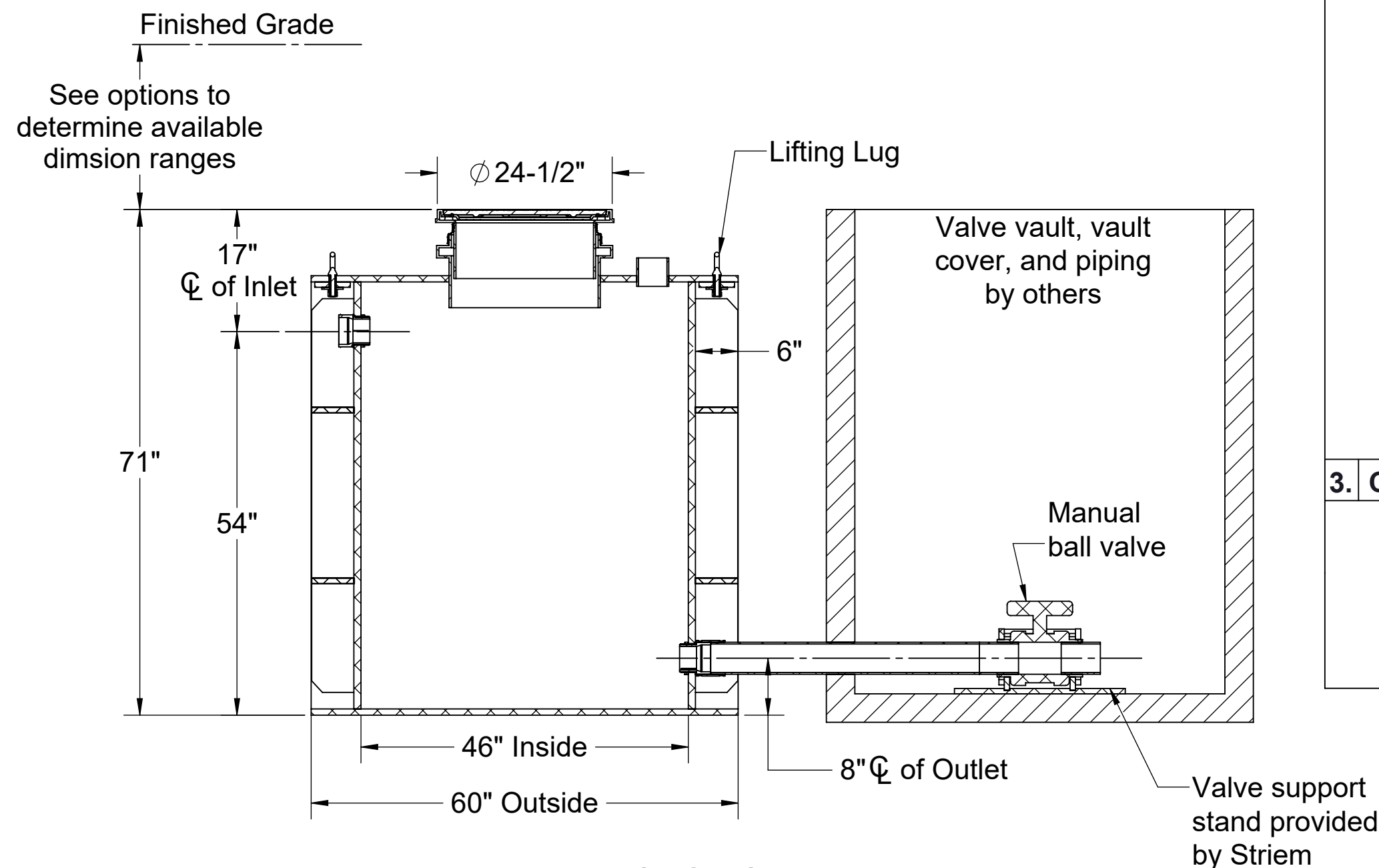
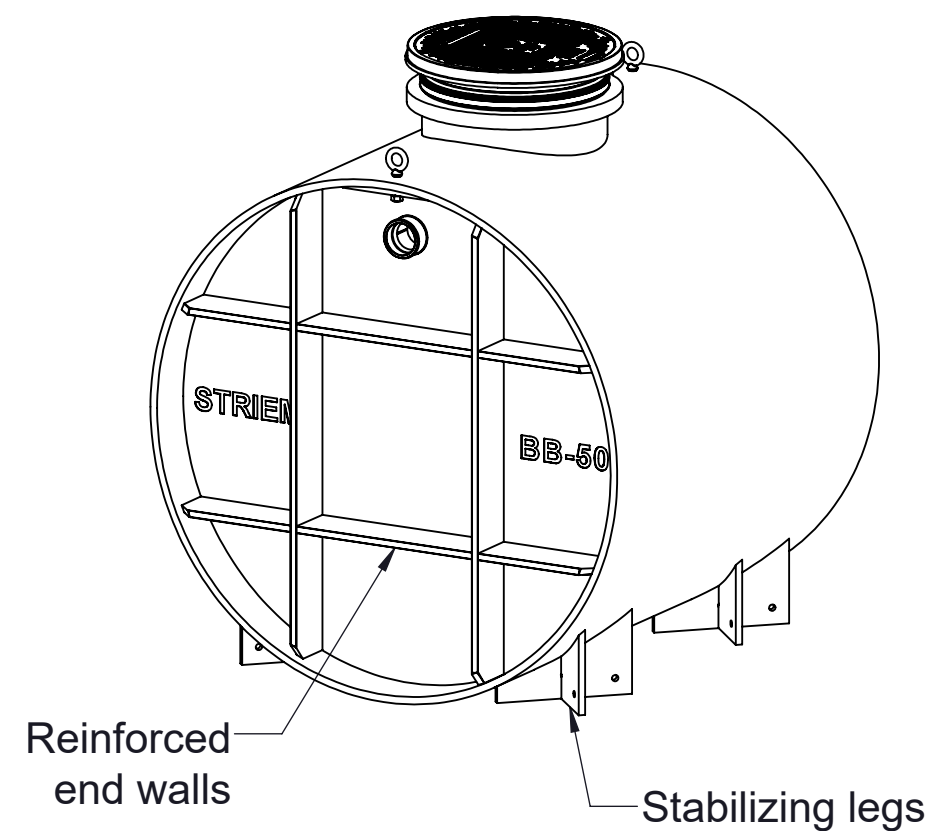

**SECTION A-A**

**Directions: Complete steps 1-3 and submit signed with purchase order.**

**1. Choose Connection Types.**

- |  |  |
|--|--|
| <b>Inlet</b>                           | <b>Size</b>  |
| <input type="checkbox"/> Plain End     | <input type="checkbox"/> 2"                        |
| <input type="checkbox"/> Female Thread | <input type="checkbox"/> 3"                        |
| <input type="checkbox"/> Flanged       | <input type="checkbox"/> 4"                        |
|  | <input type="checkbox"/> 6" (female not available) |
| <b>Outlet</b>                          | <b>Size</b>  |
| <input type="checkbox"/> Plain End     | <input type="checkbox"/> 2"                        |
| <input type="checkbox"/> Female Thread | <input type="checkbox"/> 3"                        |
| <input type="checkbox"/> Flanged       | <input type="checkbox"/> 4"                        |
|  | <input type="checkbox"/> 6" (female not available) |
| <b>Vent</b>                            | <b>Size</b>  |
| <input type="checkbox"/> Plain End     | <input type="checkbox"/> 2"                        |
| <input type="checkbox"/> Female Thread | <input type="checkbox"/> 3"                        |
| <input type="checkbox"/> Flanged       | <input type="checkbox"/> 4"                        |

**2. Riser Options.**

- Included : 0" - 5"**
- SR24** : >5" - 24"
  - LR24** : >24" - 39"
  - SR24 (2)** : >39" - 43"
  - SR24 + LR24** : >43" - 58"
  - LR24 (2)** : >58" - 72"
  - SR24 + LR24 (2)** : >72" - 90"
  - LR24 (3)** : >90" - 106"
- OR -**
- CPRK** : >11" - 106"
    - Corrugated Pipe Riser Kit.
    - Used in substitute of SR/LR riser options.
    - 18" diameter corrugated pipe by others.
    - See CPRK specification for more detail.

**3. Choose Additional Options.**

- HDK-CWT-500** - High Water Table Hold Down Kit
- AVA-3** - Single Level Monitoring Package \*
- AVA-4** - Multi-Level Monitoring Package \*

\*Monitoring packages will raise covers by 3".

Signature of Approval: \_\_\_\_\_  
 Company: \_\_\_\_\_  
 Date of Approval: \_\_\_\_\_  
 Specifying Engineer: \_\_\_\_\_  
 Engineering Firm: \_\_\_\_\_

PO IS NON-CANCELABLE  
 ORDER IS NON-RETURNABLE

<b>MODEL NUMBER:</b>	BB-500
<b>DESCRIPTION:</b>	POLYETHYLENE DECONTAMINATION TANK WITH MANUAL BALL VALVE 500 GALLON CAPACITY
<b>DWG BY:</b>	WLF
<b>DATE:</b>	4/23/21
<b>REV:</b>	0
<b>ECO:</b>	

**SPECIFICATION SHEET**

**Striem**  
 3100 Brinkerhoff  
 Kansas City, KS 66115  
 Tel: 913-222-1500  
 orders@striemco.com  
 www.striemco.com



Made in the U.S.A

PROPRIETARY AND CONFIDENTIAL

THE INFORMATION CONTAINED IN THIS DRAWING IS THE SOLE PROPERTY OF STRIEM, LLC. ANY REPRODUCTION IN PART OR AS A WHOLE WITHOUT THE WRITTEN PERMISSION OF STRIEM, LLC. IS PROHIBITED.

**SPECIFICATIONS**

1. Liquid holding capacity: 500 gallons (66.7 cu. ft.).
2. Unit weight with composite cover: 750 lbs.
3. Maximum operating temperature 140°F continuous.
4. Highway rated cover: 16,000 lb. load rating.

**NOTES**

1. For gravity drainage applications only. Do not use for pressure applications.
2. 7/8" thick seamless High Density Polyethylene.
3. Unit supplied with built-in adapter for up to 5" of adjustability. Additional riser(s) available for deeper burial depth.
4. Cover placement allows full access to tank for proper maintenance.
5. For buried applications.
6. Lifting lug set for easy install.

**ENGINEER SPECIFICATION GUIDE**

Striem Bio Basin model BB-500 shall be lifetime guaranteed and made in USA of seamless, molded High Density Polyethylene with minimum 7/8" uniform wall thickness. Tank shall be furnished for below grade installation with field adjustable riser system. Cover shall provide water/gas-tight seal and have a maximum 16,000 lbs load rating.

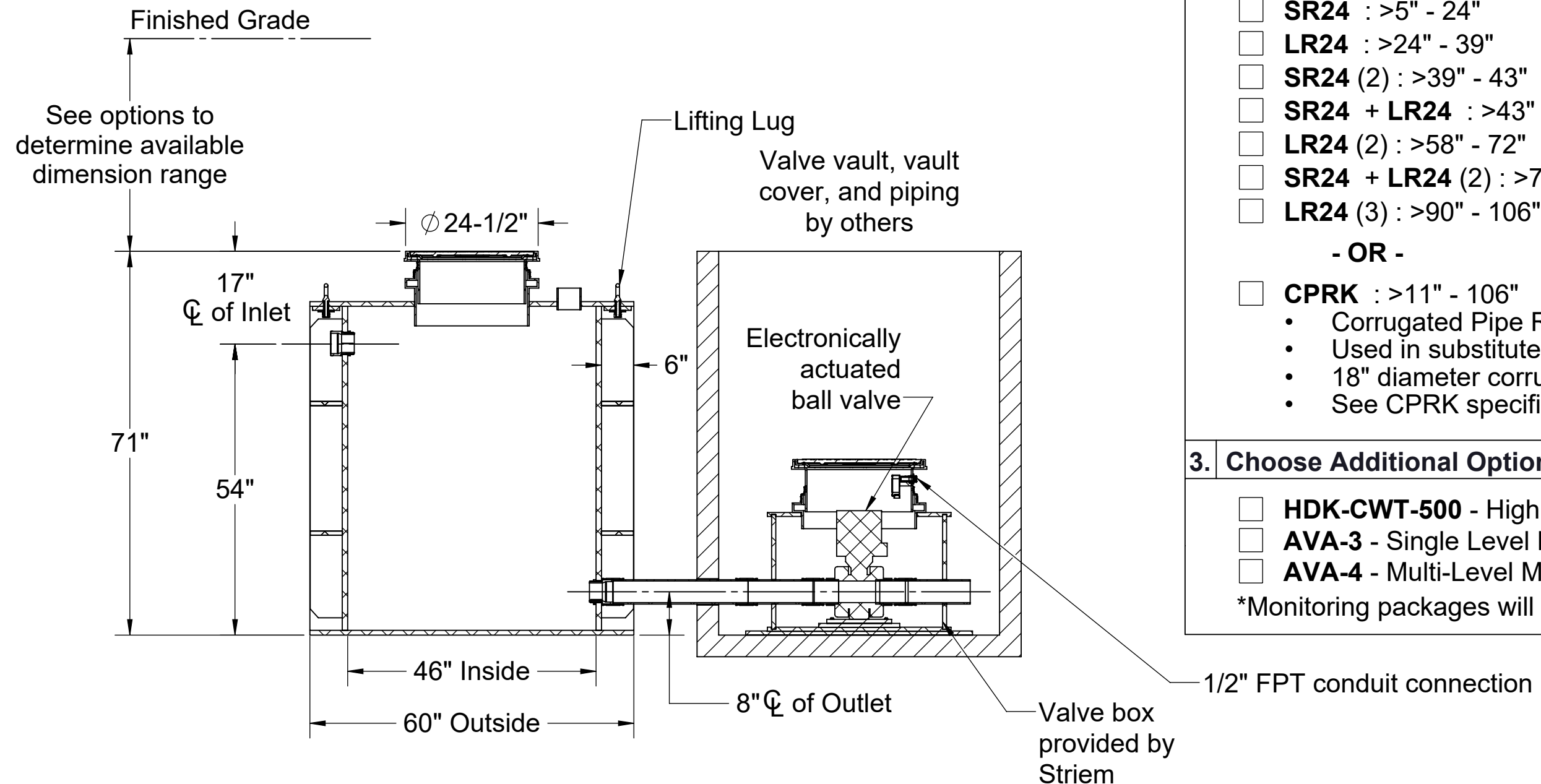
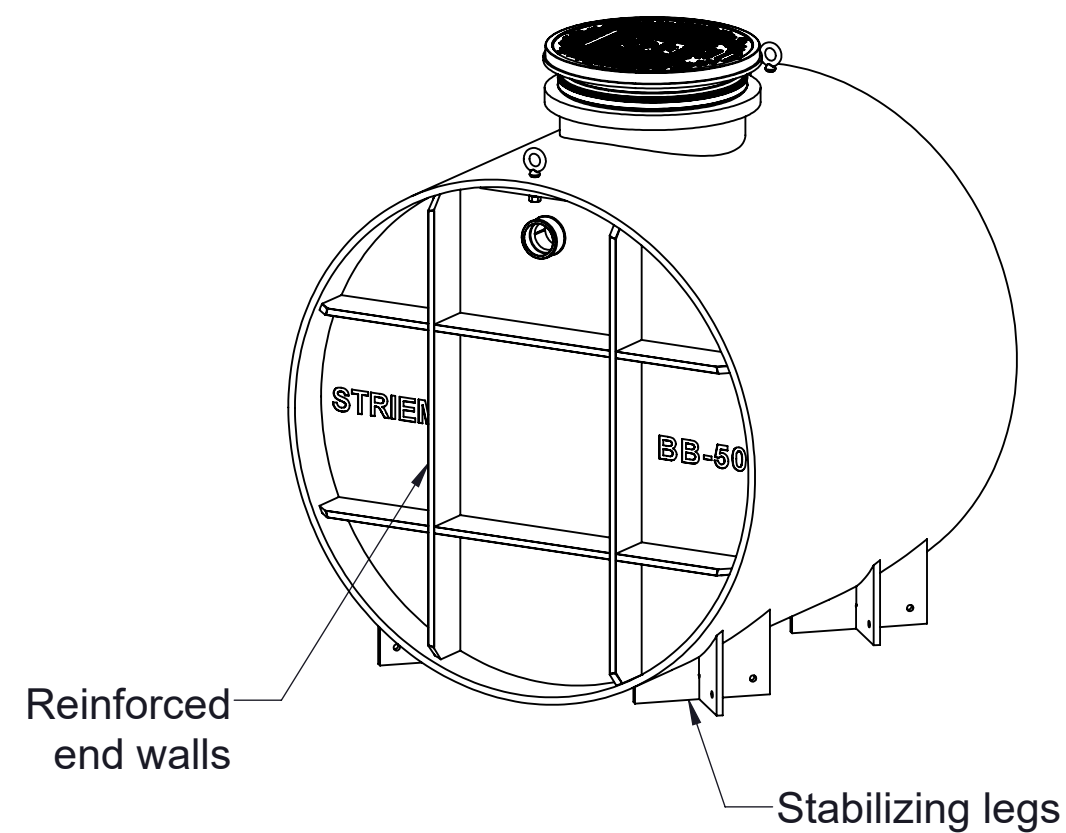
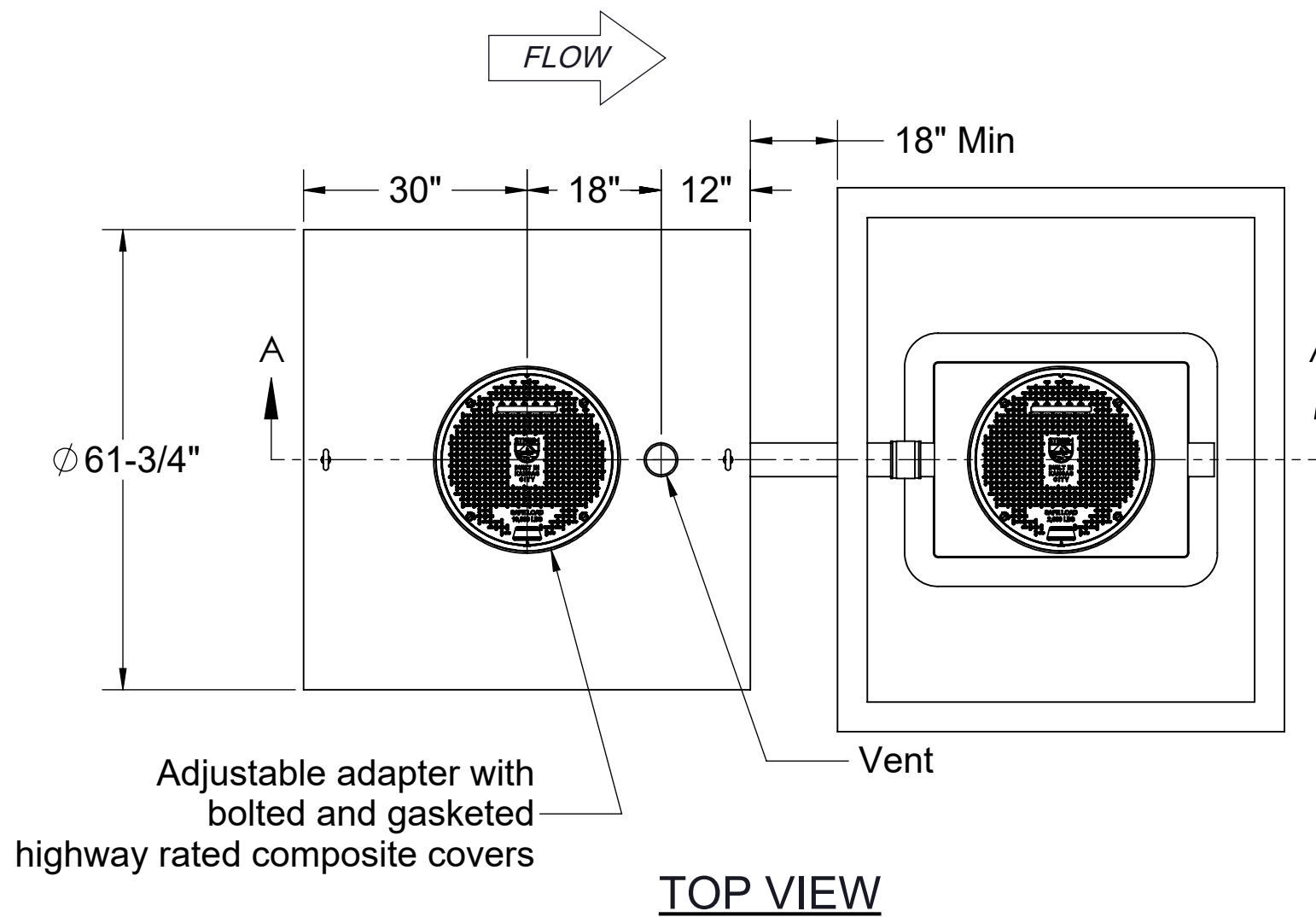

**SECTION A-A**

**Directions: Complete steps 1-3 and submit signed with purchase order.**

**1. Choose Connection Types.**

- |  |  |
|--|--|
| <b>Inlet</b>                           | <b>Size</b>  |
| <input type="checkbox"/> Plain End     | <input type="checkbox"/> 2"                        |
| <input type="checkbox"/> Female Thread | <input type="checkbox"/> 3"                        |
| <input type="checkbox"/> Flanged       | <input type="checkbox"/> 4"                        |
|  | <input type="checkbox"/> 6" (female not available) |
| <b>Outlet</b>                          | <b>Size</b>  |
| <input type="checkbox"/> Plain End     | <input type="checkbox"/> 2"                        |
| <input type="checkbox"/> Female Thread | <input type="checkbox"/> 3"                        |
| <input type="checkbox"/> Flanged       | <input type="checkbox"/> 4"                        |
|  | <input type="checkbox"/> 6" (female not available) |
| <b>Vent</b>                            | <b>Size</b>  |
| <input type="checkbox"/> Plain End     | <input type="checkbox"/> 2"                        |
| <input type="checkbox"/> Female Thread | <input type="checkbox"/> 3"                        |
| <input type="checkbox"/> Flanged       | <input type="checkbox"/> 4"                        |

**2. Riser Options.**

- Included : 0" - 5"**
- SR24** : >5" - 24"
  - LR24** : >24" - 39"
  - SR24 (2)** : >39" - 43"
  - SR24 + LR24** : >43" - 58"
  - LR24 (2)** : >58" - 72"
  - SR24 + LR24 (2)** : >72" - 90"
  - LR24 (3)** : >90" - 106"
- OR -**
- CPRK** : >11" - 106"
    - Corrugated Pipe Riser Kit.
    - Used in substitute of SR/LR riser options.
    - 18" diameter corrugated pipe by others.
    - See CPRK specification for more detail.

**3. Choose Additional Options.**

- HDK-CWT-500** - High Water Table Hold Down Kit
  - AVA-3** - Single Level Monitoring Package \*
  - AVA-4** - Multi-Level Monitoring Package \*
- \*Monitoring packages will raise covers by 3".

**SHEET 3**

Signature of Approval: \_\_\_\_\_  
 Company: \_\_\_\_\_  
 Date of Approval: \_\_\_\_\_  
 Specifying Engineer: \_\_\_\_\_  
 Engineering Firm: \_\_\_\_\_

PO IS NON-CANCELABLE  
 ORDER IS NON-RETURNABLE

<b>MODEL NUMBER:</b>	BB-500
<b>DESCRIPTION:</b>	POLYETHYLENE DECONTAMINATION TANK WITH ELECTRONICALLY ACTUATED BALL VALVE 500 GALLON CAPACITY
<b>DWG BY:</b>	WLF
<b>DATE:</b>	4/23/21
<b>REV:</b>	0
<b>ECO:</b>	

**SPECIFICATION SHEET**

**Striem**  
 3100 Brinkerhoff  
 Kansas City, KS 66115  
 Tel: 913-222-1500  
 orders@striemco.com  
 www.striemco.com



Made in the U.S.A

PROPRIETARY AND CONFIDENTIAL

THE INFORMATION CONTAINED IN THIS DRAWING IS THE SOLE PROPERTY OF STRIEM, LLC. ANY REPRODUCTION IN PART OR AS A WHOLE WITHOUT THE WRITTEN PERMISSION OF STRIEM, LLC. IS PROHIBITED.