

SPECIFICATIONS

1. 6" Plain End inlet shown, 3" Plain End vents standard.
2. Liquid holding capacity: 1500 gallons (201 cu. ft.).
3. Unit weight: 1496 lbs.
4. Maximum operating temperature 140°F continuous.

NOTES

1. For gravity drainage applications only.
2. Do not use for pressure applications.
3. Cover placement allows full access to tank for proper maintenance.
4. Lifting lug set for easy install.

ENGINEER SPECIFICATION GUIDE

Striem decontamination tank model BB-1500 shall be lifetime guaranteed and made in the USA. Tank shall be constructed of polyethylene with 7/8" nominal wall thickness. Tank shall be manufactured for below-grade installation. Field-adjustable riser system is available as an option to bring manhole covers to grade. Tank liquid holding capacity shall be 1500 gallons. Covers shall provide water/gas-tight seal and have a maximum 16,000 lbs. load capacity.

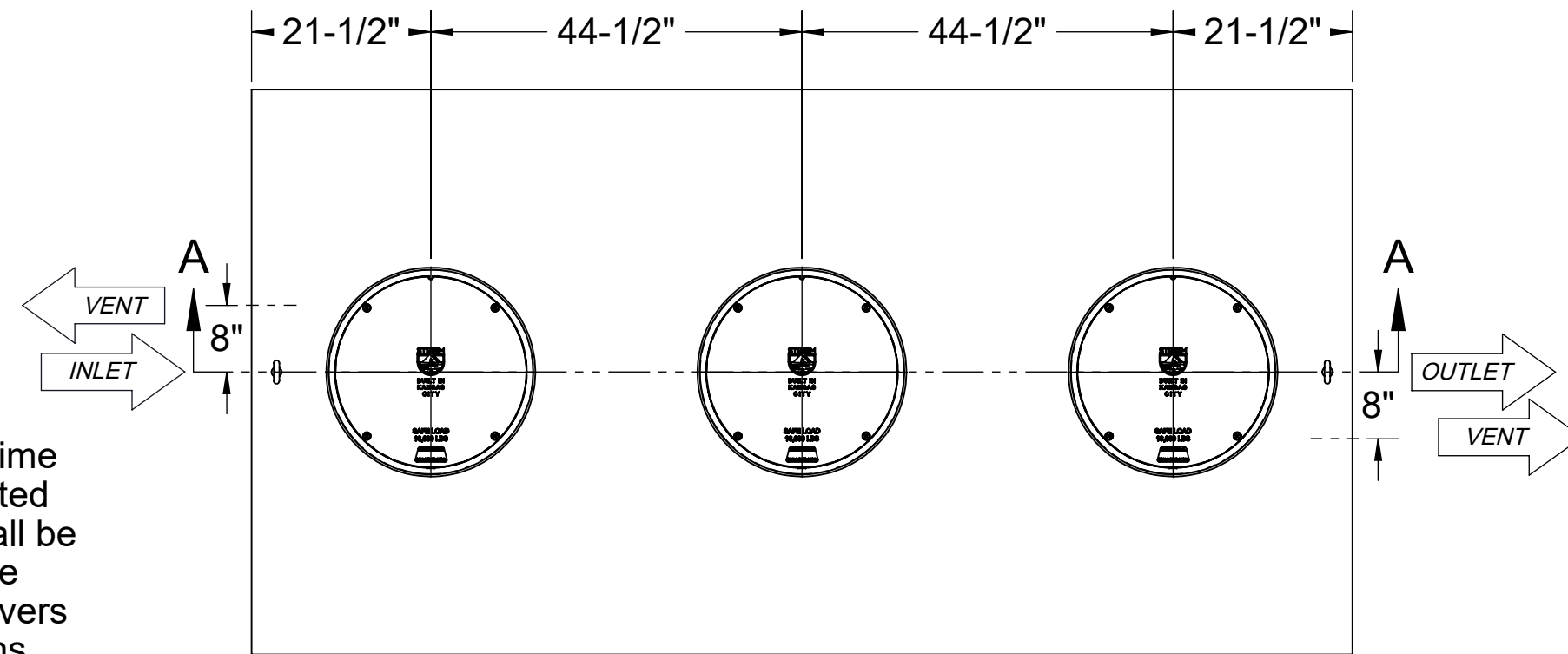

TOP VIEW

OPTIONS		
Connection Options (Plain End Only)		
Inlet	Optional Outlet	SELECTION REQUIRED
<input type="checkbox"/> 3"	<input type="checkbox"/> 3"	
<input type="checkbox"/> 4"	<input type="checkbox"/> 4"	
<input type="checkbox"/> 6"	<input type="checkbox"/> 6"	
Riser Options		
From Factory: 0" - 5"		
<input type="checkbox"/> Up to 24": SR24 (3)		
<input type="checkbox"/> Up to 39": LR24 (3)		
<input type="checkbox"/> Up to 43": SR24 (6)		
<input type="checkbox"/> Up to 58": SR24 (3) + LR24 (3)		
<input type="checkbox"/> Up to 72": LR24 (6)		
<input type="checkbox"/> Up to 90": SR24 (3) + LR24 (6)		
<input type="checkbox"/> Up to 106": LR24 (9)		
- OR -		
<input type="checkbox"/> CPRK (3): 11" - 106" (See specification for more detail.)		
Additional Options		
<input type="checkbox"/> HDK-6 : High Water Table Hold Down Kit		
<input type="checkbox"/> AVA-3 : Single-Level Monitoring Package *		
<input type="checkbox"/> AVA-4 : Multi-Level Monitoring Package *		
*Monitoring packages will raise covers by 3"		

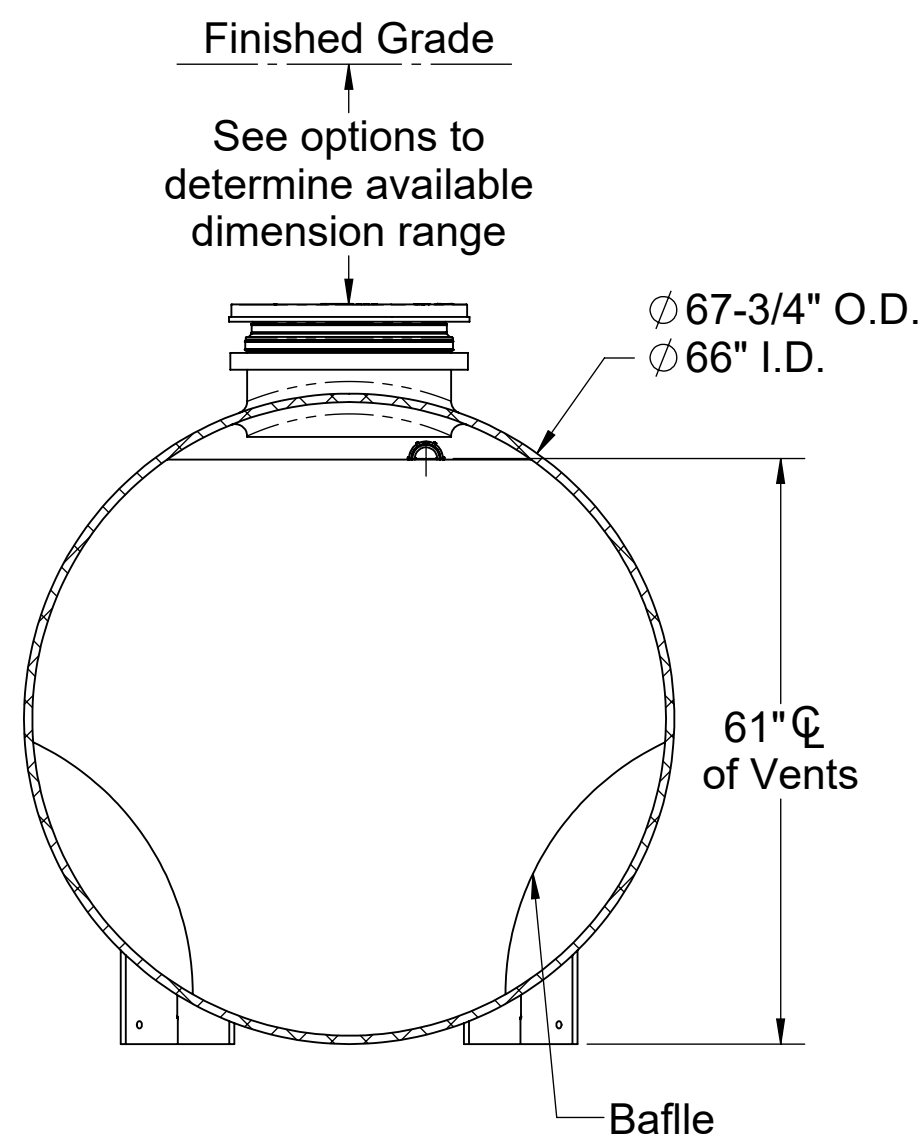

SECTION B-B

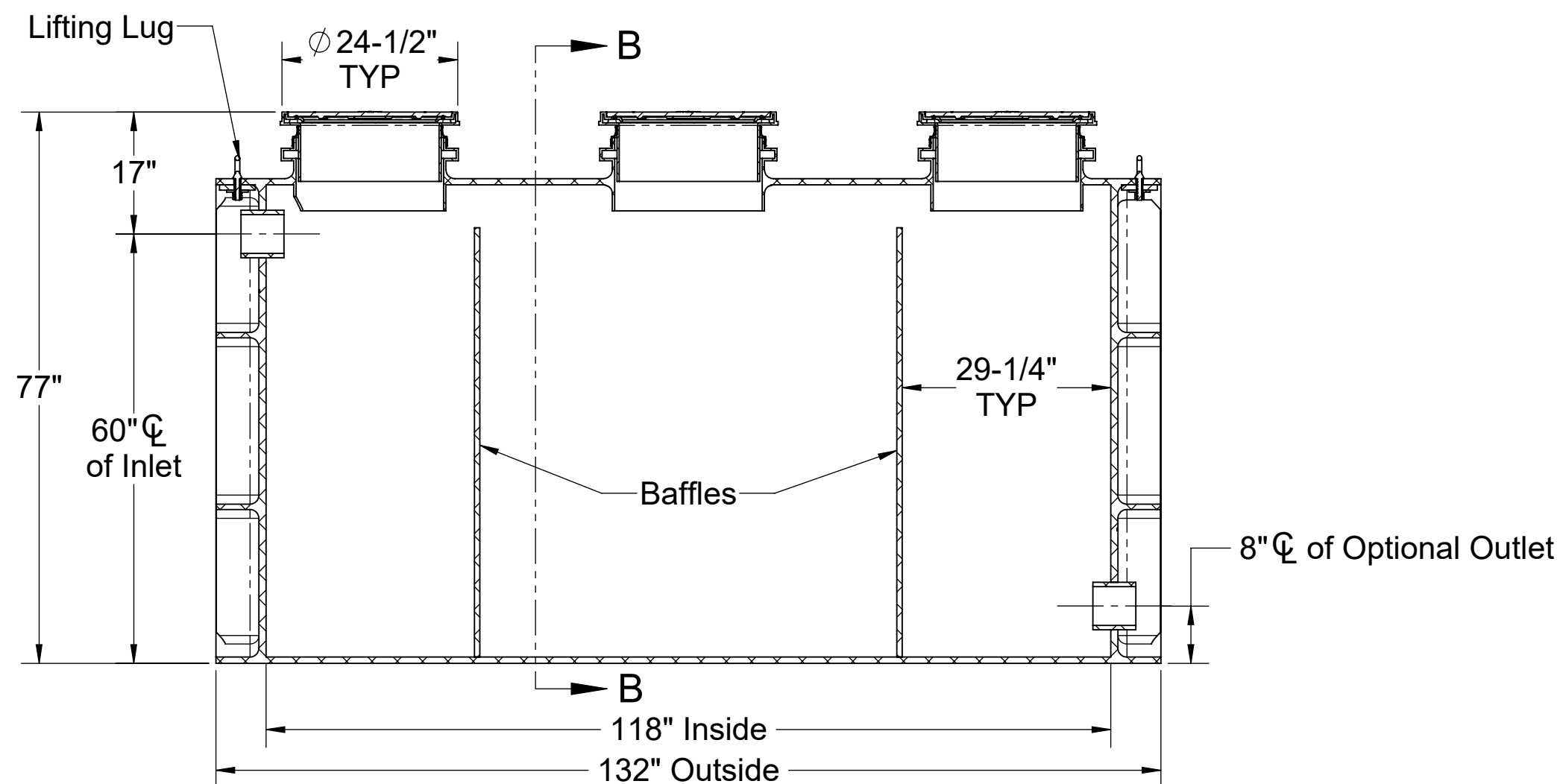

SECTION A-A

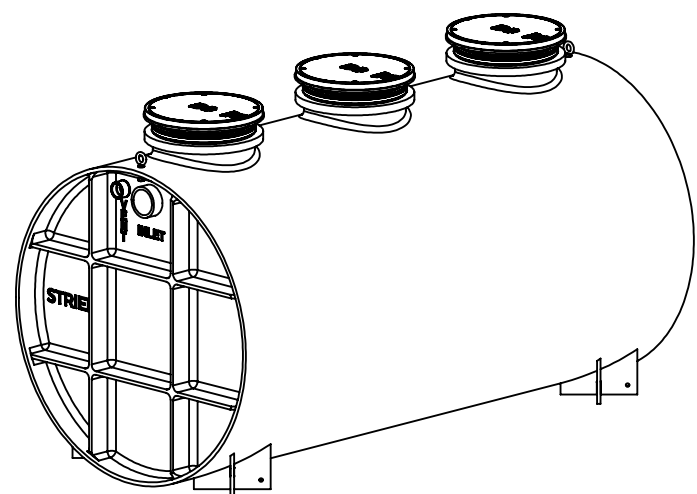

PO IS NON-CANCELABLE
ORDER IS NON-RETURNABLE

MODEL NUMBER:	BB-1500
DESCRIPTION:	BIO BASIN™ POLYETHYLENE DECONTAMINATION TANK 1500 GALLON CAPACITY
DWG BY: ENG	DATE: 8/22/2023
REV: 1	

SPECIFICATION SHEET

Striem
Kansas City, KS
Tel: 913-222-1500
orders@striemco.com
www.striemco.com

Made in the U.S.A

