

SPECIFICATIONS

1. 6" Plain End inlet shown, 2" Plain End pump outlet, 3" Plain End vents standard.
2. Liquid holding capacity: 1500 gallons (201 cu. ft.).
3. Unit weight: 1496 lbs.
4. Maximum operating temperature 140°F continuous.

NOTES

1. For gravity drainage applications only.
2. Do not use for pressure applications.
3. Cover placement allows full access to tank for proper maintenance.
4. Lifting lug set for easy install.

ENGINEER SPECIFICATION GUIDE

Striem decontamination tank model BB-1500-PP shall be lifetime guaranteed and made in the USA. Tank shall be constructed of polyethylene with 7/8" nominal wall thickness. Tank shall be manufactured for below-grade installation. Field-adjustable riser system is available as an option to bring manhole covers to grade. Tank liquid holding capacity shall be 1500 gallons. Covers shall provide water/gas-tight seal and have a maximum 16,000 lbs. load capacity.

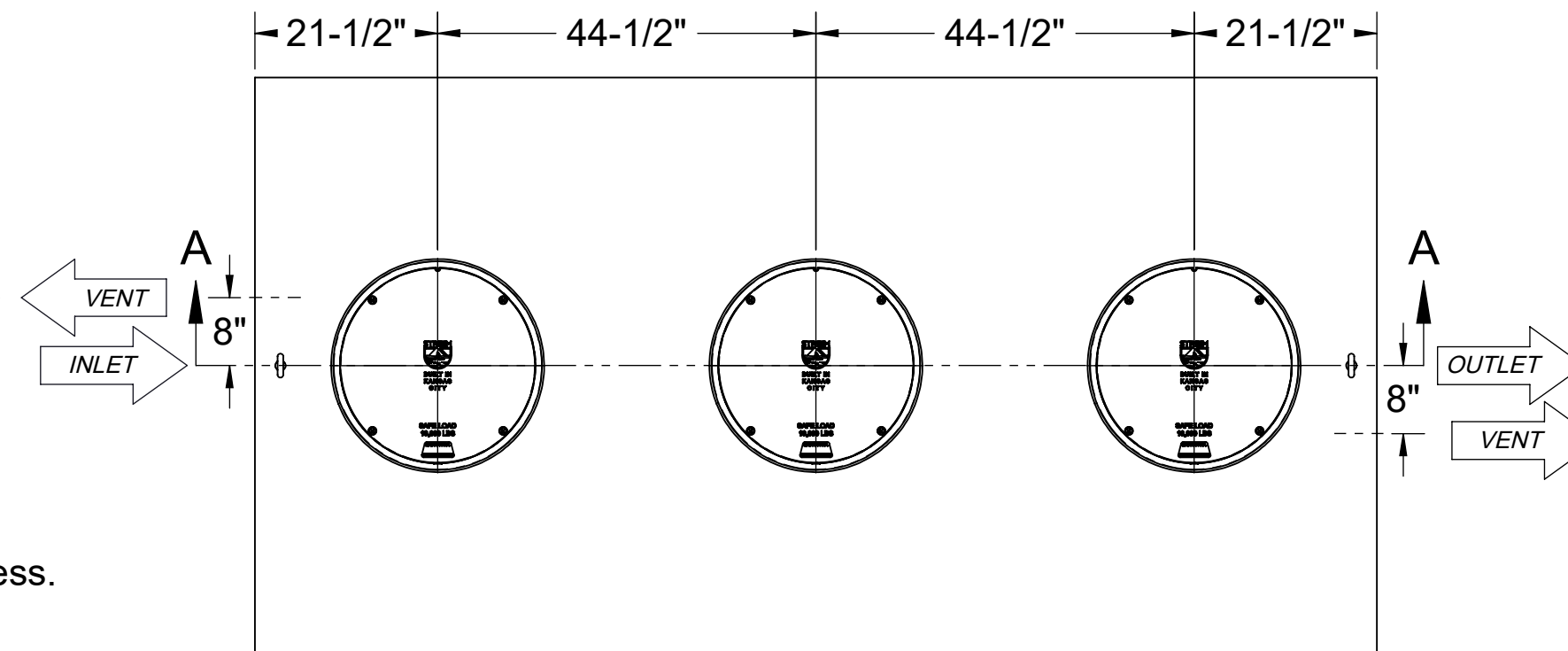

TOP VIEW

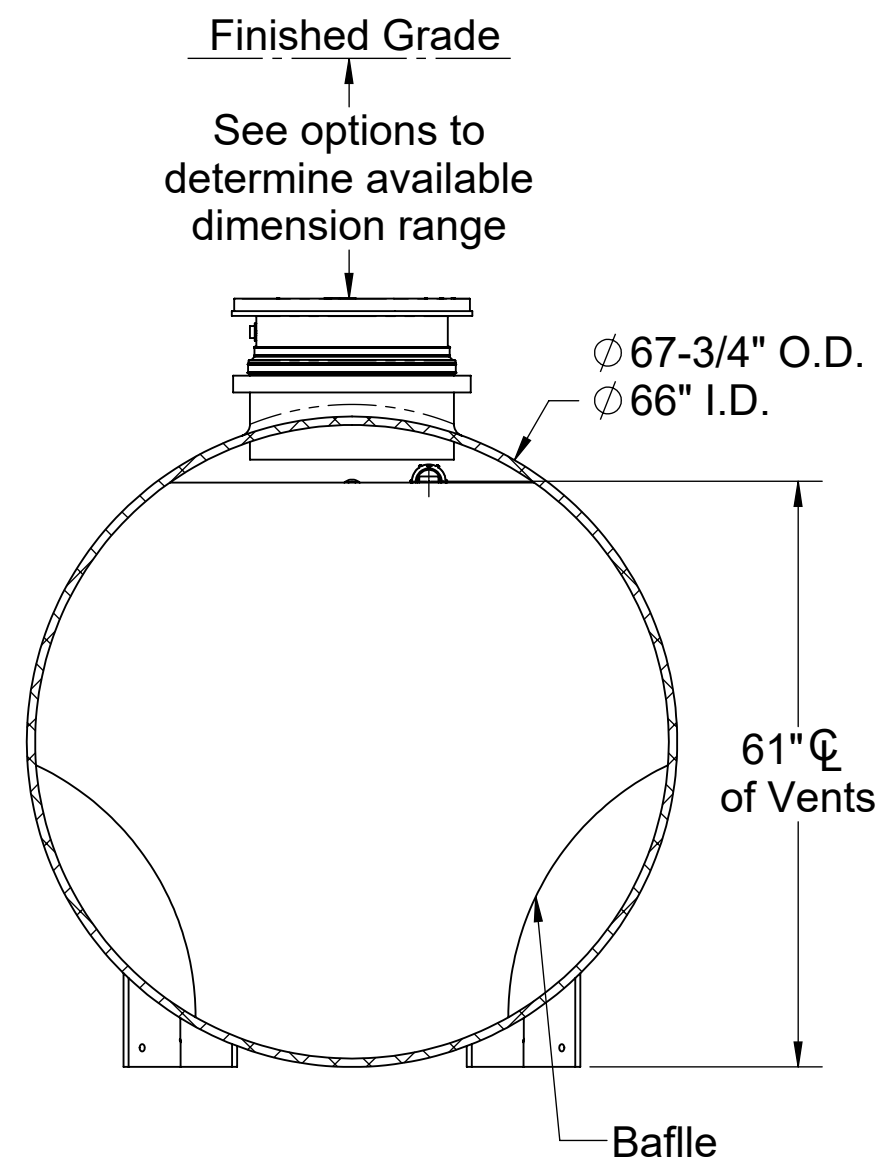

SECTION B-B

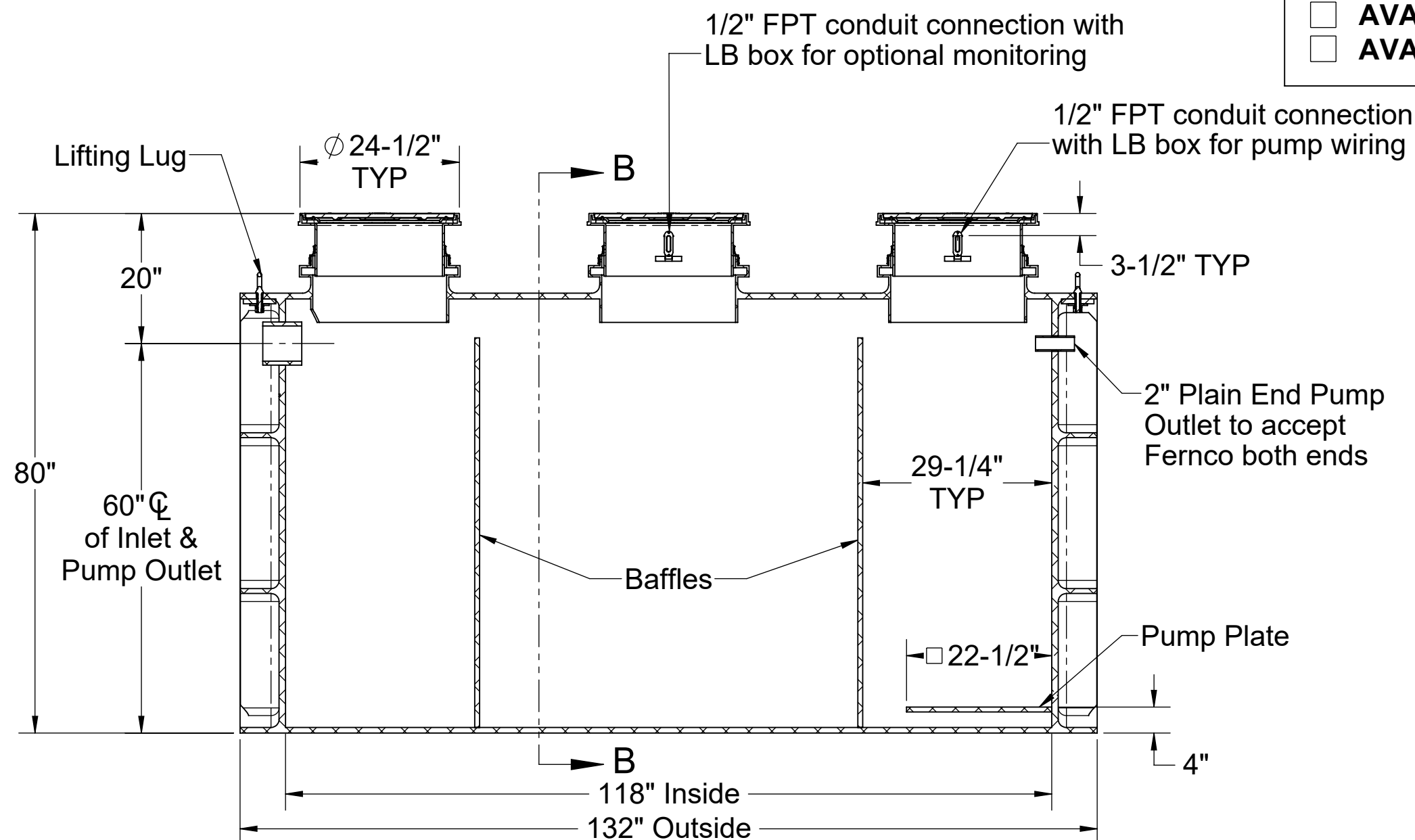

SECTION A-A

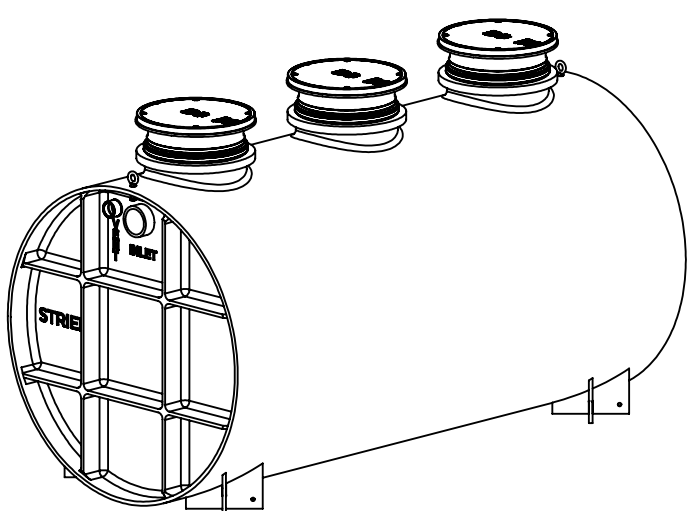

PO IS NON-CANCELABLE ORDER IS NON-RETURNABLE

PROPRIETARY AND CONFIDENTIAL THE INFORMATION CONTAINED IN THIS DRAWING IS THE SOLE PROPERTY OF STRIEM, LLC. ANY REPRODUCTION IN PART OR AS A WHOLE WITHOUT THE WRITTEN PERMISSION OF STRIEM, LLC. IS PROHIBITED.

OPTIONS

Connection Options (Plain End Only)

- Inlet**
- 3" SELECTION REQUIRED
 - 4"
 - 6"

Riser Options

From Factory: Up to 2"

- Up to 21": **SR24** (3)
- Up to 36": **LR24** (3)
- Up to 40": **SR24** (6)
- Up to 55": **SR24** (3) + **LR24** (3)
- Up to 69": **LR24** (6)
- Up to 87": **SR24** (3) + **LR24** (6)
- Up to 103": **LR24** (9)

- OR -

- CPRK** (3): 11" - 103" (See specification for more detail.)

Additional Options

- HDK-6**: High Water Table Hold Down Kit
- AVA-3**: Single-Level Monitoring Package
- AVA-4**: Multi-Level Monitoring Package

MODEL NUMBER: BB-1500-PP

DESCRIPTION:
 BIO BASIN™
 POLYETHYLENE DECONTAMINATION TANK
 WITH PUMP PLATE
 1500 GALLONS CAPACITY

DWG BY: ENG **DATE:** 7/26/2023 **REV:** 2

SPECIFICATION SHEET

Striem
 Kansas City, KS
 Tel: 913-222-1500
 orders@striemco.com
 www.striemco.com

Made in the U.S.A

