

**SPECIFICATIONS**

1. 3" Plain end vents standard.
2. Liquid holding capacity: 1500 gallons (201 cu. ft.).
3. Unit weight: 1536 lbs.
4. Maximum operating temperature 140°F continuous.
5. Highway rated covers: 16,000 lb. load rating.

**NOTES**

1. For gravity drainage applications only. Do not use for pressure applications.
2. Cover placement allows full access to tank for proper maintenance.
3. Lifting lug set for easy install.
4. For below grade installation only.

**ENGINEER SPECIFICATION GUIDE**

Striem Bio Basin model BB-1500 shall be lifetime guaranteed and made in USA of High Density Polyethylene with minimum 7/8" uniform wall thickness. Tank shall be furnished for below grade installation with field adjustable riser system. Cover shall provide water/gas-tight seal and have a maximum 16,000 lbs load rating.

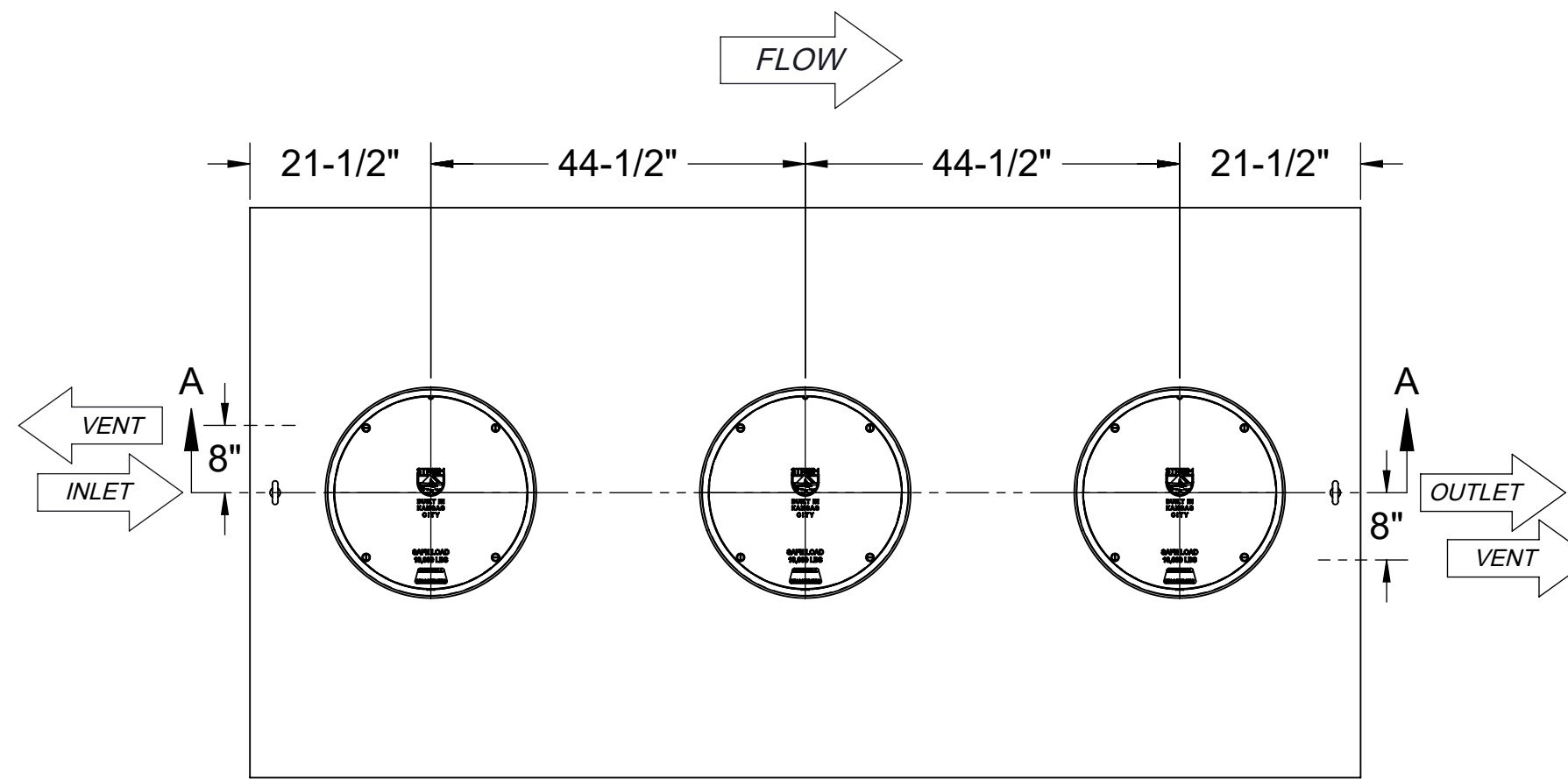

**TOP VIEW**

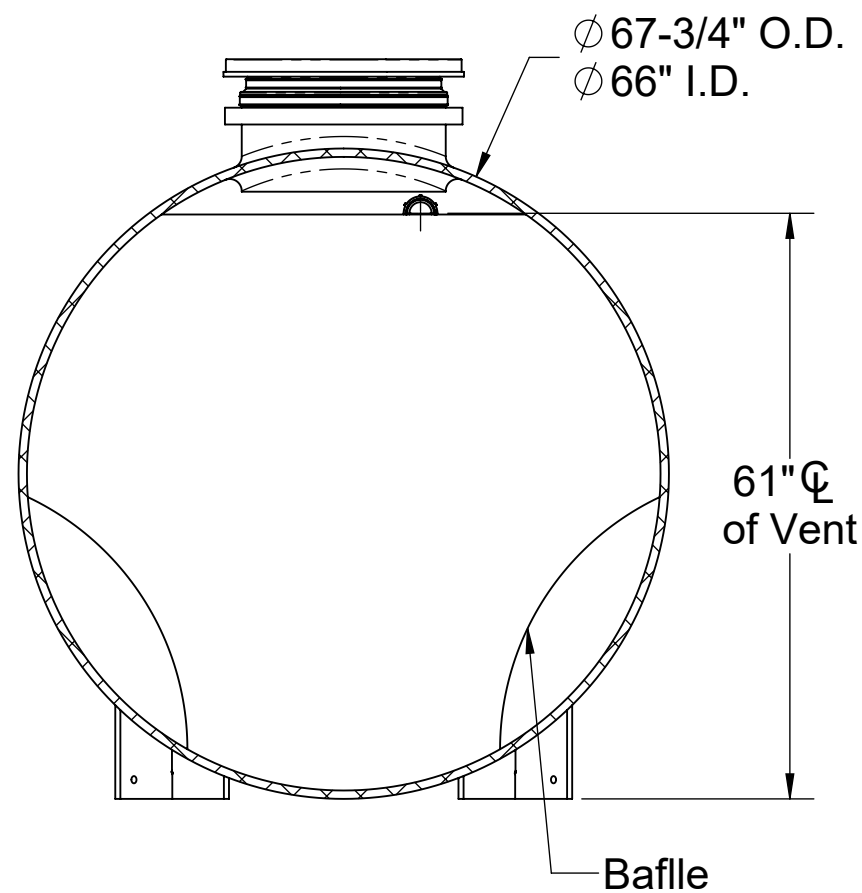

**SECTION B-B**

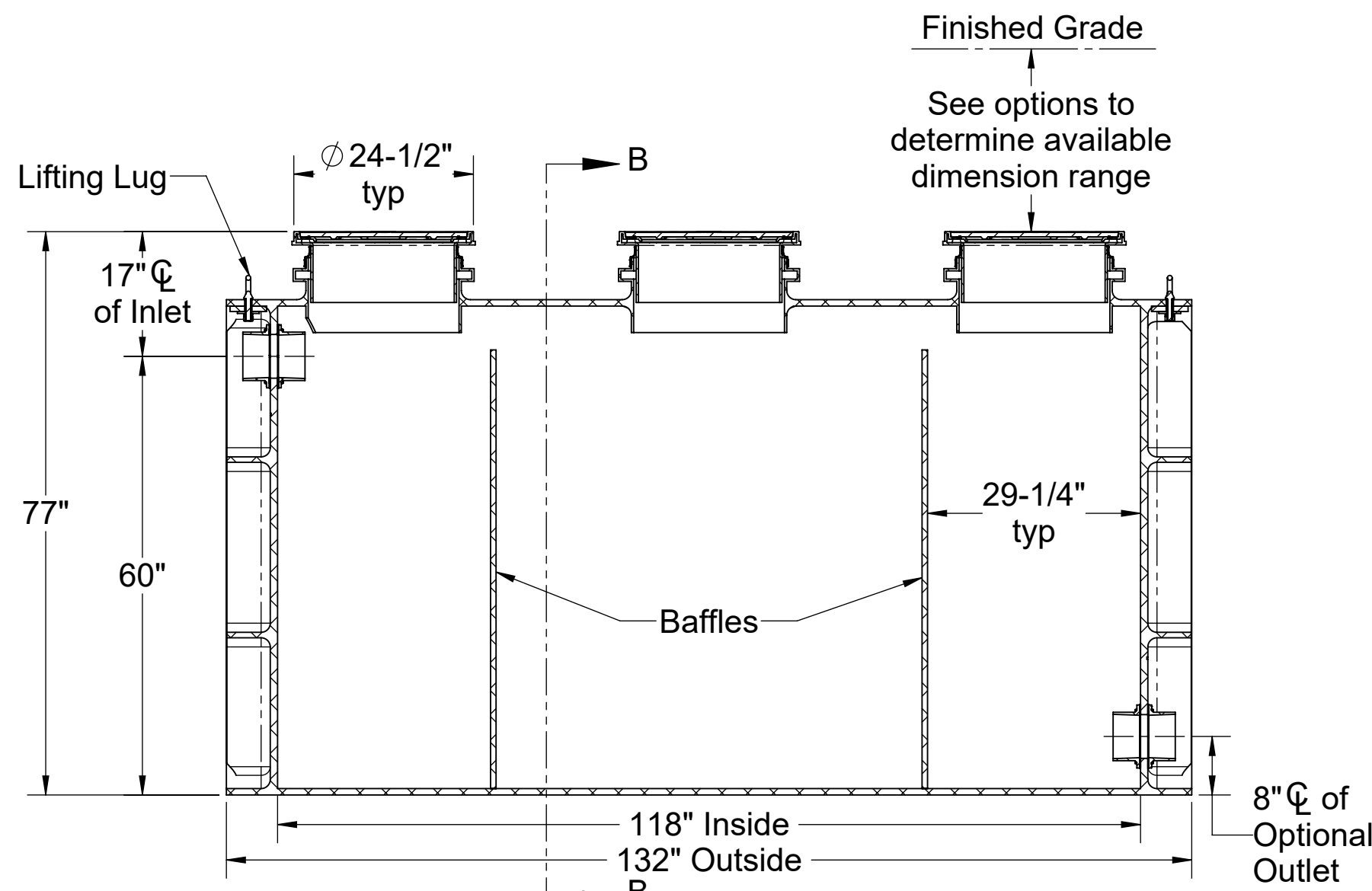

**SECTION A-A**

**Directions: Complete steps 1-3 and submit signed with purchase order.**

**1. Choose Connection Types.**

- |  |  |
|--|--|
| <b>Inlet</b>                           | <b>Size</b>                                  |
| <input type="checkbox"/> Plain End     | <input type="checkbox"/> 3"                  |
| <input type="checkbox"/> Female Thread | <input type="checkbox"/> 4"                  |
|  | <input type="checkbox"/> 6" (Plain End Only) |
| <b>Optional Outlet</b>                 | <b>Size</b>                                  |
| <input type="checkbox"/> Plain End     | <input type="checkbox"/> 3"                  |
| <input type="checkbox"/> Female Thread | <input type="checkbox"/> 4"                  |
|  | <input type="checkbox"/> 6" (Plain End Only) |

**2. Riser Options.**

- Included: 0" - 5"**
- SR24** (3): 5" - 24"
  - LR24** (3): 24" - 39"
  - SR24** (6): 39" - 43"
  - SR24** (3) + **LR24** (3): 43" - 58"
  - LR24** (6): 58" - 72"
  - SR24** (3) + **LR24** (6): 72" - 90"
  - LR24** (9): 90" - 106"
- OR -**
- CPRK** (3): 11" - 106"
    - Corrugated Pipe Riser Kit.
    - Used in substitute of SR/LR riser options.
    - 18" diameter corrugated pipe by others.
    - See CPRK specification for more detail.

**3. Choose Additional Options.**

- HDK-6**: High Water Table Hold Down Kit
- AVA-3**: Single Level Monitoring Package \*
- AVA-4**: Multi-Level Monitoring Package \*
- MBV**: Manual Ball Valve (specification available upon request)
- EAV**: Electronically Actuated Valve (specification available upon request)

\*Monitoring packages will raise covers by 3".

Signature of Approval: \_\_\_\_\_  
 Company: \_\_\_\_\_  
 Date of Approval: \_\_\_\_\_  
 Specifying Engineer: \_\_\_\_\_  
 Engineering Firm: \_\_\_\_\_

PO IS NON-CANCELABLE  
 ORDER IS NON-RETURNABLE

<b>MODEL NUMBER:</b> BB-1500	
<b>DESCRIPTION:</b> POLYETHYLENE DECONTAMINATION TANK 1500 GALLON CAPACITY	
<b>DWG BY:</b> MJ	<b>DATE:</b> 01/20/2022 <b>REV:</b> 0 <b>ECO:</b>

<b>SPECIFICATION SHEET</b>	
<b>Striem</b> 3100 Brinkerhoff Kansas City, KS 66115 Tel: 913-222-1500 orders@striemco.com www.striemco.com	
Made in the U.S.A	

THE INFORMATION CONTAINED IN THIS DRAWING IS THE SOLE PROPERTY OF STRIEM, LLC. ANY REPRODUCTION IN PART OR AS A WHOLE WITHOUT THE WRITTEN PERMISSION OF STRIEM, LLC. IS PROHIBITED.