

**SPECIFICATIONS**

1. 4" Plain End inlet, 2" Plain End vents standard.
2. Liquid holding capacity: 250 Gallons.
3. Unit weight: 225 lbs.
4. Maximum operating temperature 140°F continuous.

**NOTES**

1. For gravity drainage applications only.
2. Do not use for pressure applications.
3. Cover placement allows full access to tank for proper maintenance.

**ENGINEER SPECIFICATION GUIDE**

Striem decontamination tank model BB-275 shall be lifetime guaranteed and made in the USA. Tank shall be constructed of polyethylene. Tank shall be manufactured for above- or below-grade installation. Field-adjustable riser system is available as an option to bring manhole covers to grade. Tank liquid holding capacity shall be 250 gallons. Covers shall provide water/gas-tight seal and have a maximum 16,000 lbs. load capacity.

**THIRD PARTY STRUCTURAL ANALYSIS**

The BB-275 has been structurally analyzed in accordance with the requirements of IBC 2012 and ASCE/SEI 7 for direct burial. The maximum burial depth and backfill material are specified in our installation instructions. The structural design has been reviewed and sealed by a professional engineer registered in the state of California. A sealed structural analysis report is available upon request.

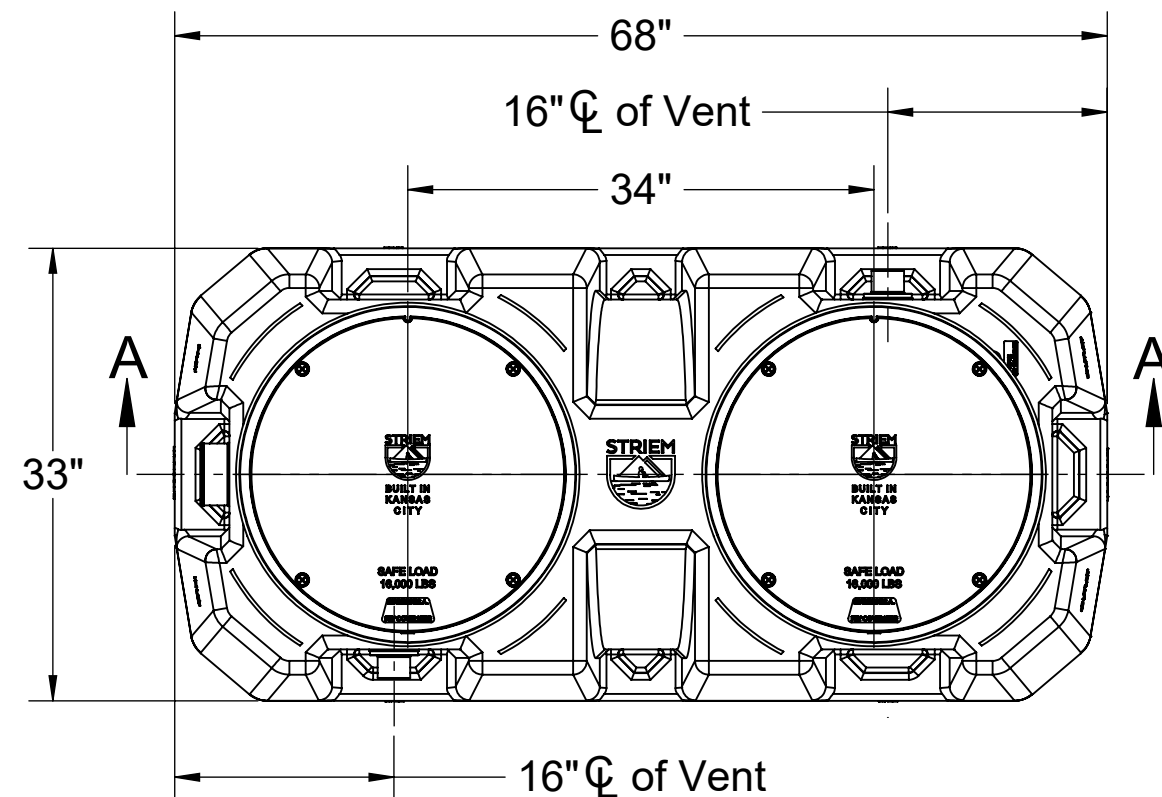

**TOP VIEW**

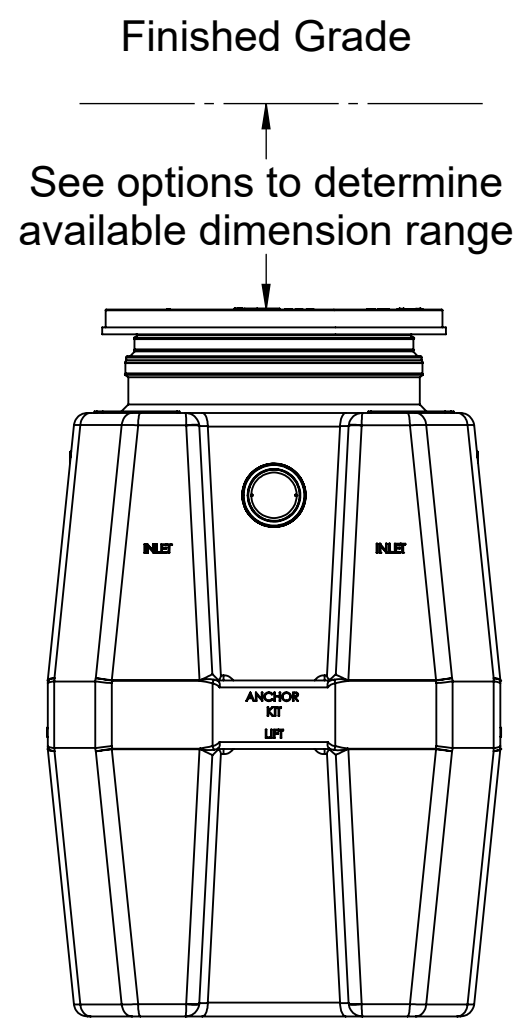

**END VIEW**

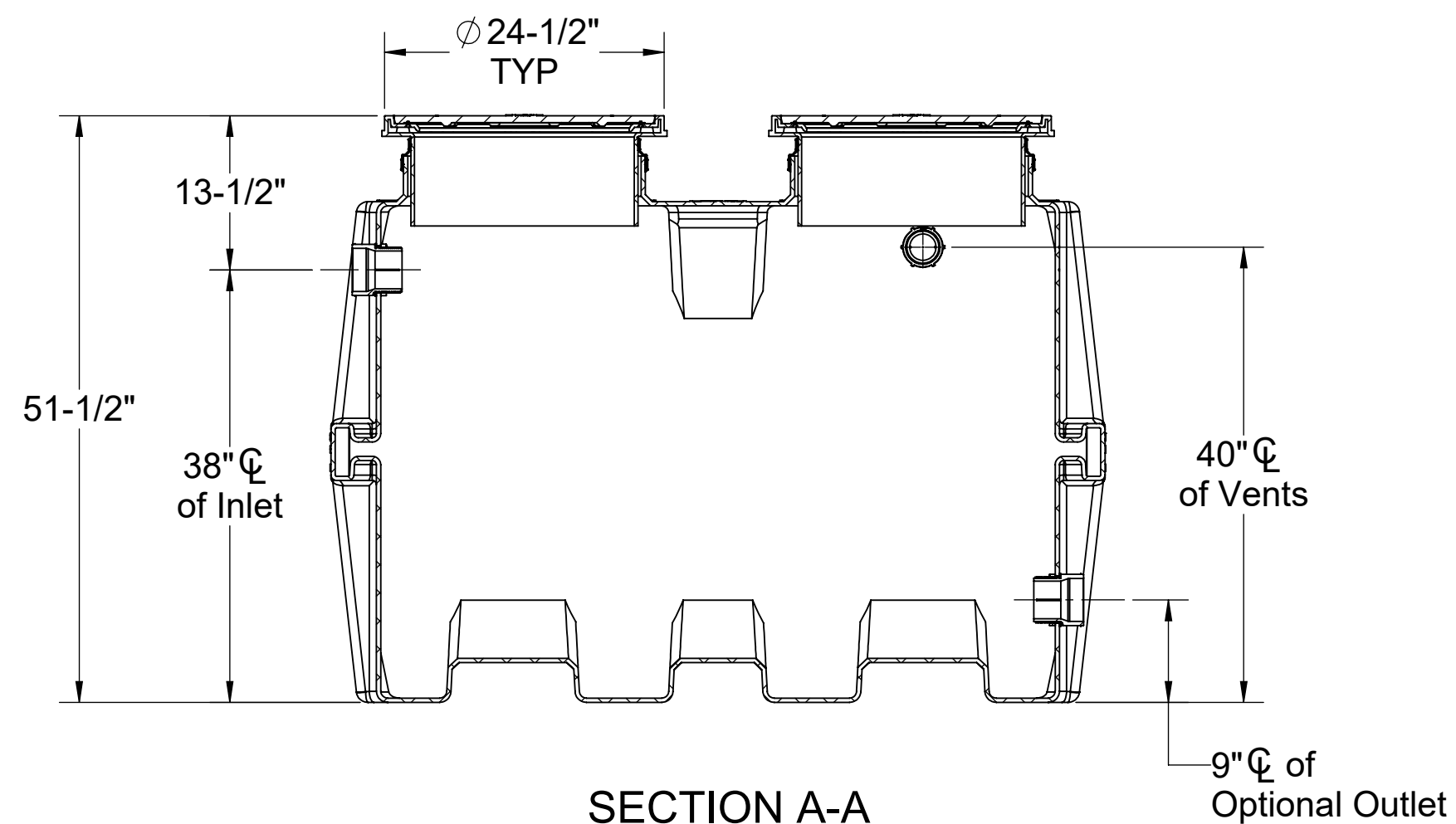

**SECTION A-A**

OPTIONS	
<b>Connection Options (Plain End Only)</b>	
<b>Inlet</b>	<b>Optional Outlet</b>
<input type="checkbox"/> 2"	<input type="checkbox"/> 2"
<input type="checkbox"/> 3"	<input type="checkbox"/> 3"
<input type="checkbox"/> 4"	<input type="checkbox"/> 4"
<input type="checkbox"/> 6"	<input type="checkbox"/> 6"
<b>SELECTION REQUIRED</b>	
<b>Riser Options</b>	
<b>From Factory: Up to 5"</b>	
<input type="checkbox"/> Up to 24": <b>SR24</b> (2)	
<input type="checkbox"/> Up to 39": <b>LR24</b> (2)	
<input type="checkbox"/> Up to 43": <b>SR24</b> (4)	
<input type="checkbox"/> Up to 58": <b>SR24</b> (2) + <b>LR24</b> (2)	
<input type="checkbox"/> Up to 72": <b>LR24</b> (4)	
<input type="checkbox"/> Up to 90": <b>SR24</b> (2) + <b>LR24</b> (4)	
<b>- OR -</b>	
<input type="checkbox"/> <b>CPRK</b> (2): 11" - 90" (See specification for more detail.)	
<b>Additional Options</b>	
<input type="checkbox"/> <b>HDK-2</b> : High Water Table Hold Down Kit	
<input type="checkbox"/> <b>AVA-3</b> : Single-Level Monitoring Package*	
<input type="checkbox"/> <b>AVA-4</b> : Multi-Level Monitoring Package*	
*Monitoring packages will raise covers by 3".	

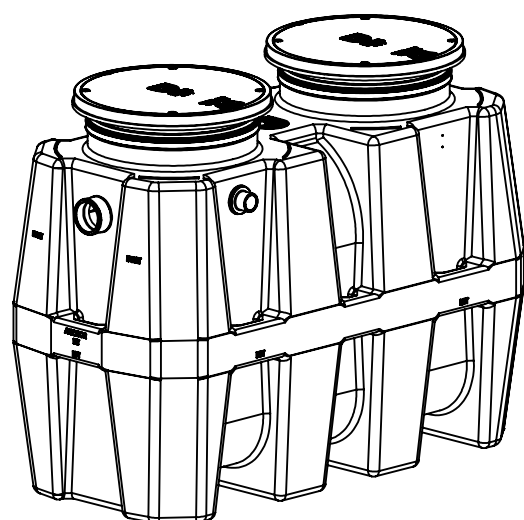

PO IS NON-CANCELABLE  
ORDER IS NON-RETURNABLE

**MODEL NUMBER:** BB-275

**DESCRIPTION:**  
BIO BASIN™  
POLYETHYLENE DECONTAMINATION TANK  
250 GALLON CAPACITY

**DWG BY:** ENG    **DATE:** 8/22/2023    **REV:** 1

**SPECIFICATION SHEET**

Striem  
Kansas City, KS  
Tel: 913-222-1500  
orders@striemco.com  
www.striemco.com

Made in the U.S.A

