

SPECIFICATIONS

1. 4" Plain End inlet shown, 2" Plain End pump outlet, 2" Plain End vents standard.
2. Liquid holding capacity: 250 Gallons
3. Unit weight: 225 Pounds
4. Maximum operating temperature 140°F continuous.

NOTES

1. For gravity drainage applications only.
2. Do not use for pressure applications.
3. Cover placement allows full access to tank for proper maintenance.

ENGINEER SPECIFICATION GUIDE

Striem decontamination tank model BB-275-PP shall be lifetime guaranteed and made in the USA. Tank shall be constructed of polyethylene. Tank shall be manufactured for above- or below-grade installation. Field-adjustable riser system is available as an option to bring manhole covers to grade. Tank liquid holding capacity shall be 250 gallons. Covers shall provide water/gas-tight seal and have a maximum 16,000 lbs. load capacity.

THIRD PARTY STRUCTURAL ANALYSIS

The BB-275-PP has been structurally analyzed in accordance with the requirements of IBC 2012 and ASCE/SEI 7 for direct burial. The maximum burial depth and backfill material are specified in our installation instructions. The structural design has been reviewed and sealed by a professional engineer registered in the state of California. A sealed structural analysis report is available upon request.

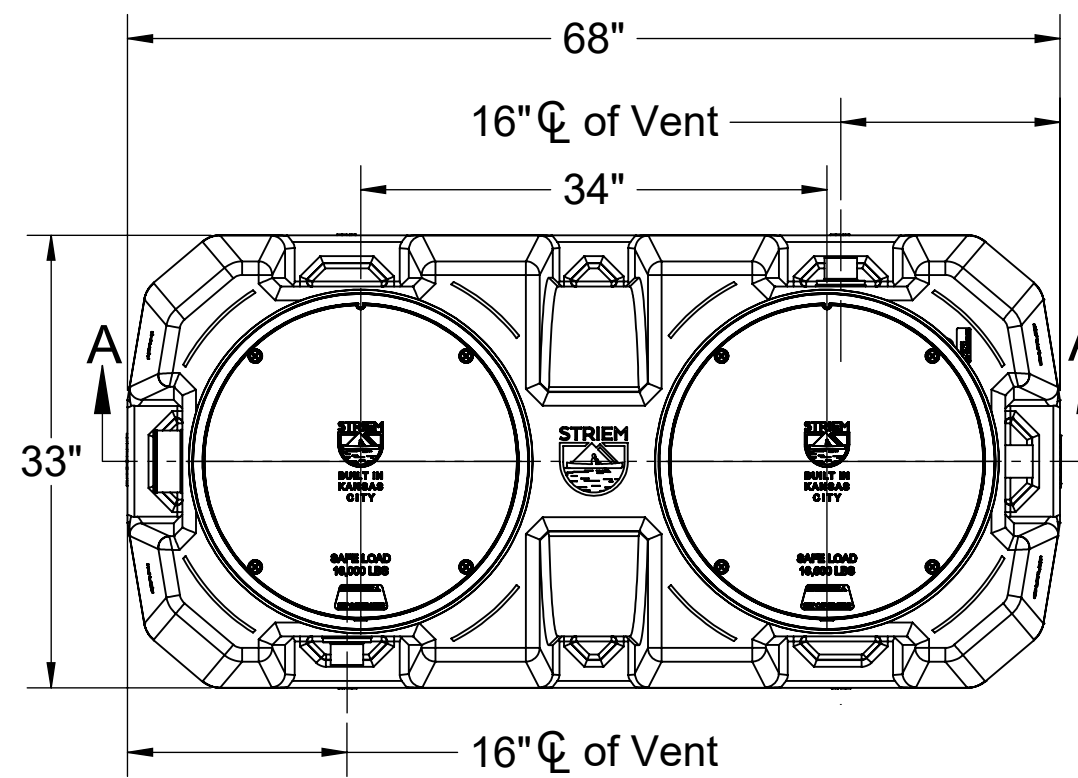

TOP VIEW

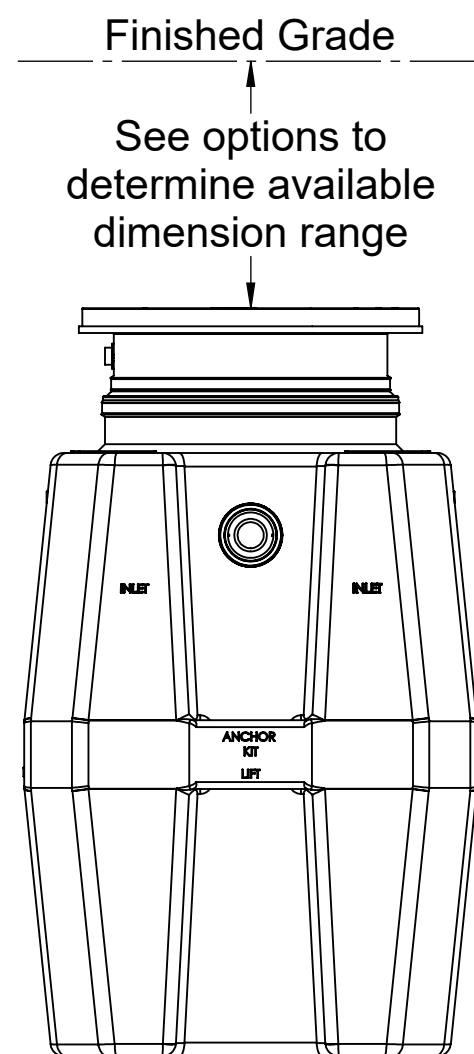

END VIEW

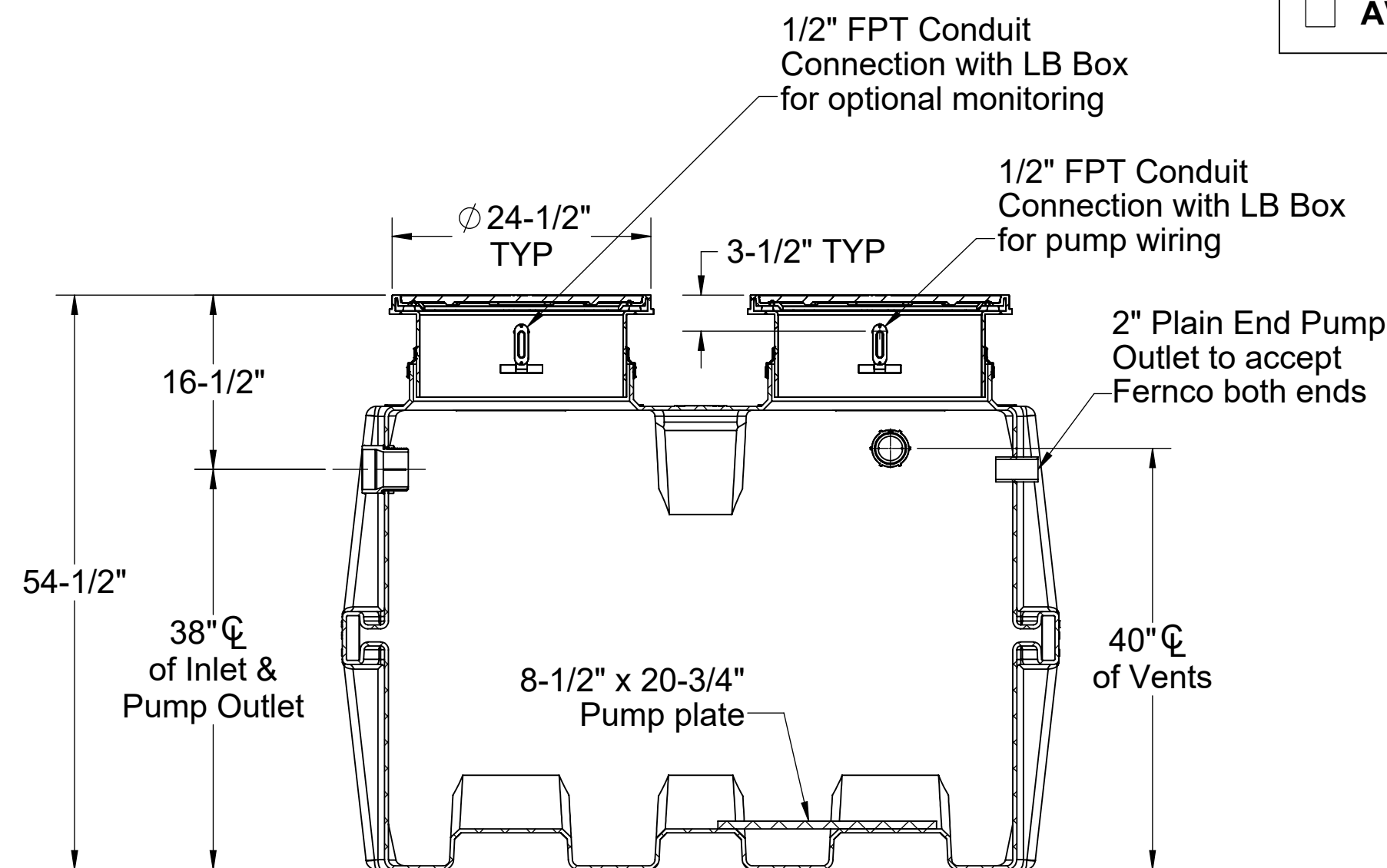

SECTION A-A

OPTIONS	
Connection Options (Plain End Only)	
Inlet	SELECTION REQUIRED
<input type="checkbox"/> 2"	
<input type="checkbox"/> 3"	
<input type="checkbox"/> 4"	
<input type="checkbox"/> 6"	
Riser Options	
From Factory: Up to 2"	
<input type="checkbox"/> Up to 21": SR24 (2)	
<input type="checkbox"/> Up to 36": LR24 (2)	
<input type="checkbox"/> Up to 40": SR24 (4)	
<input type="checkbox"/> Up to 55": SR24 (2) + LR24 (2)	
<input type="checkbox"/> Up to 69": LR24 (4)	
<input type="checkbox"/> Up to 87": SR24 (2) + LR24 (4)	
- OR -	
<input type="checkbox"/> CPRK (2): 11" - 87" (See specification for more detail.)	
Additional Options	
<input type="checkbox"/> HDK-2 : High Water Table Hold Down Kit	
<input type="checkbox"/> AVA-3 : Single-Level Monitoring Package	
<input type="checkbox"/> AVA-4 : Multi-Level Monitoring Package	

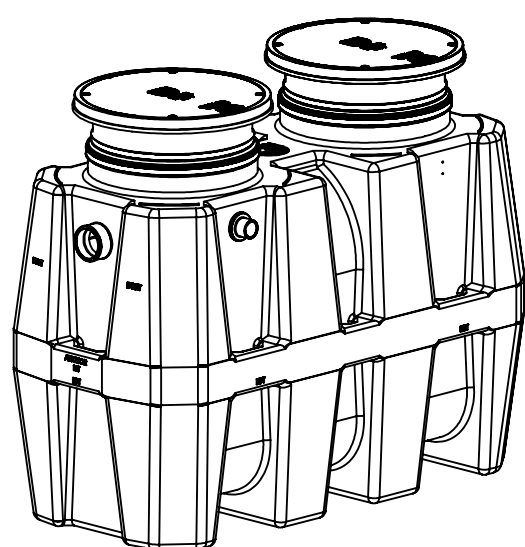

PO IS NON-CANCELABLE
ORDER IS NON-RETURNABLE

PROPRIETARY AND CONFIDENTIAL
THE INFORMATION CONTAINED IN THIS DRAWING IS THE SOLE PROPERTY OF STRIEM, LLC.
ANY REPRODUCTION IN PART OR AS A WHOLE WITHOUT THE WRITTEN PERMISSION OF STRIEM, LLC. IS PROHIBITED.

MODEL NUMBER: BB-275-PP	SPECIFICATION SHEET	
DESCRIPTION: BIO BASIN™ POLYETHYLENE DECONTAMINATION TANK WITH PUMP PLATE 250 GALLON CAPACITY	Striem Kansas City, KS Tel: 913-222-1500 orders@striemco.com www.striemco.com	
DWG BY: ENG DATE: 7/25/2023 REV: 1	Made in the U.S.A	