

SPECIFICATIONS

1. 4" Plain End inlet/outlet, 3" Plain End vents, C24-H cover standard.
2. Liquid capacity: 110 gallons (14.7 cu.ft.).
3. Solids capacity: 11 gallons.
4. Flammable liquid capacity: 93 gallons.
5. Unit weight w/ standard cover: 120 lbs.; w/ cast iron cover: 180 lbs.
6. Maximum operating temperature 140°F continuous.

NOTES

1. For gravity drainage applications only.
2. Do not use for pressure applications.
3. Cover placement allows full access to tank for proper maintenance.
4. Narrow footprint allows clearance through doorways and down stairs.
5. Outlet diptube is removable to inspect/clean piping.

ENGINEER SPECIFICATION GUIDE

Striem flammable liquid interceptor model FLI-125 shall be lifetime guaranteed and made in the USA. Interceptor shall be constructed of polyethylene. Interceptor shall be manufactured for above- or below-grade installation. Field-adjustable riser system is available as an option to bring manhole cover to grade. Interceptor liquid holding capacity shall be 110 gallons and flammable liquid capacity shall be 93 gallons. Solids capacity shall be 11 gallons. Cover shall provide water/gas-tight seal and have a maximum 16,000 lbs. load capacity.

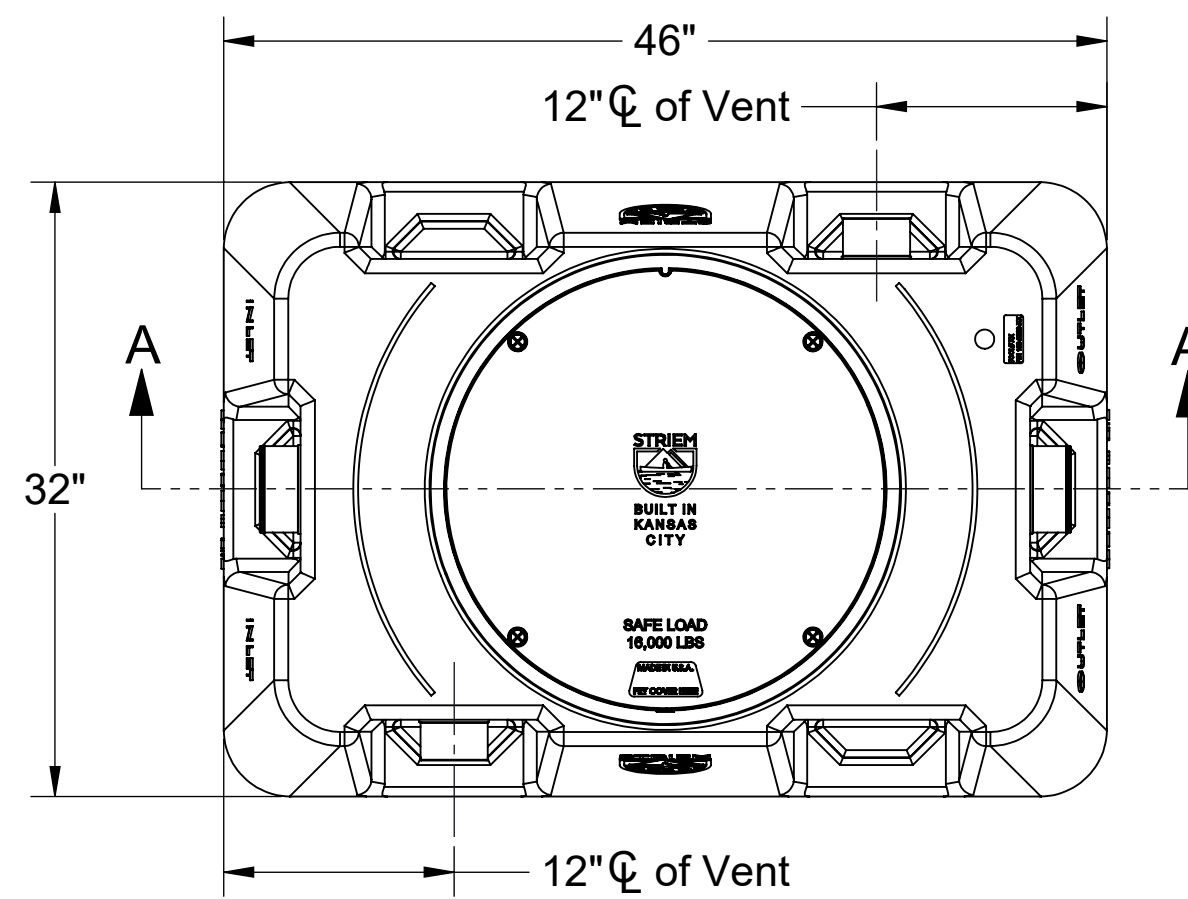

TOP VIEW

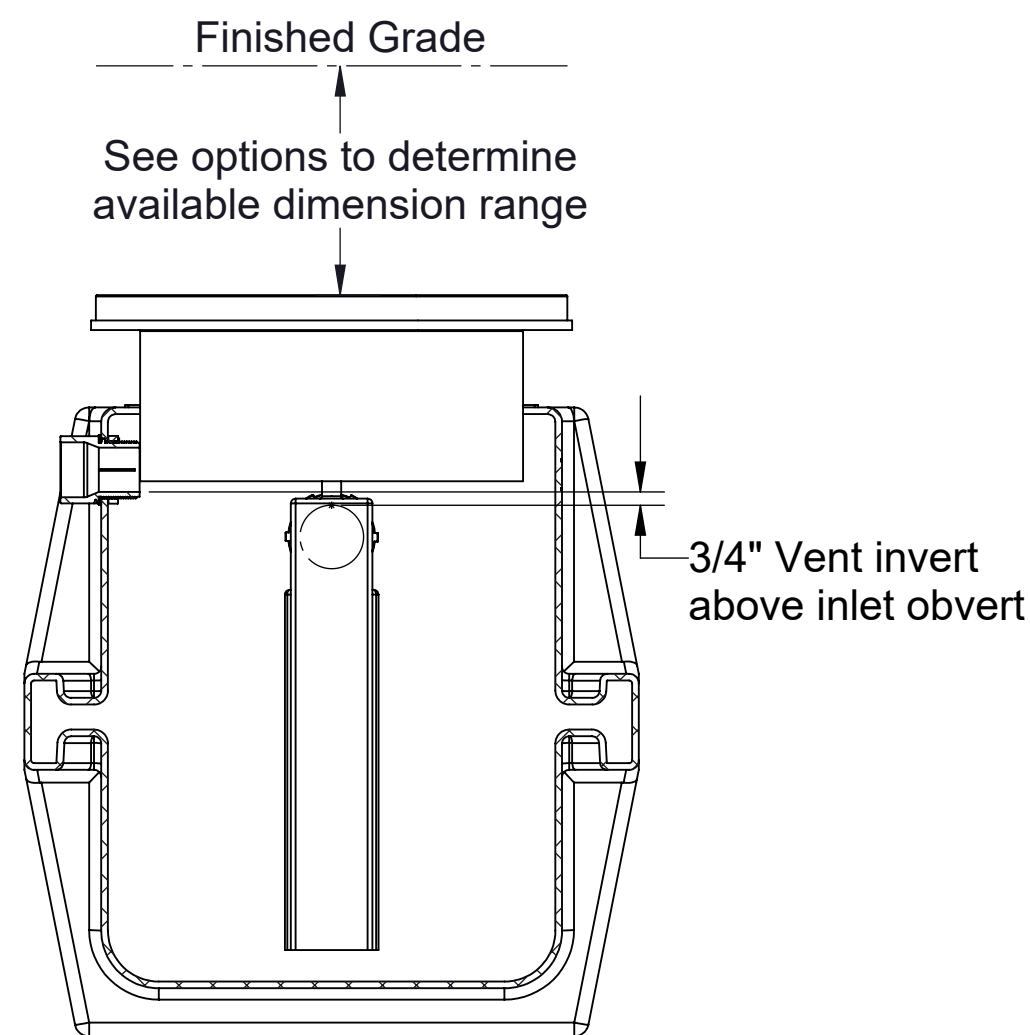

SECTION B-B

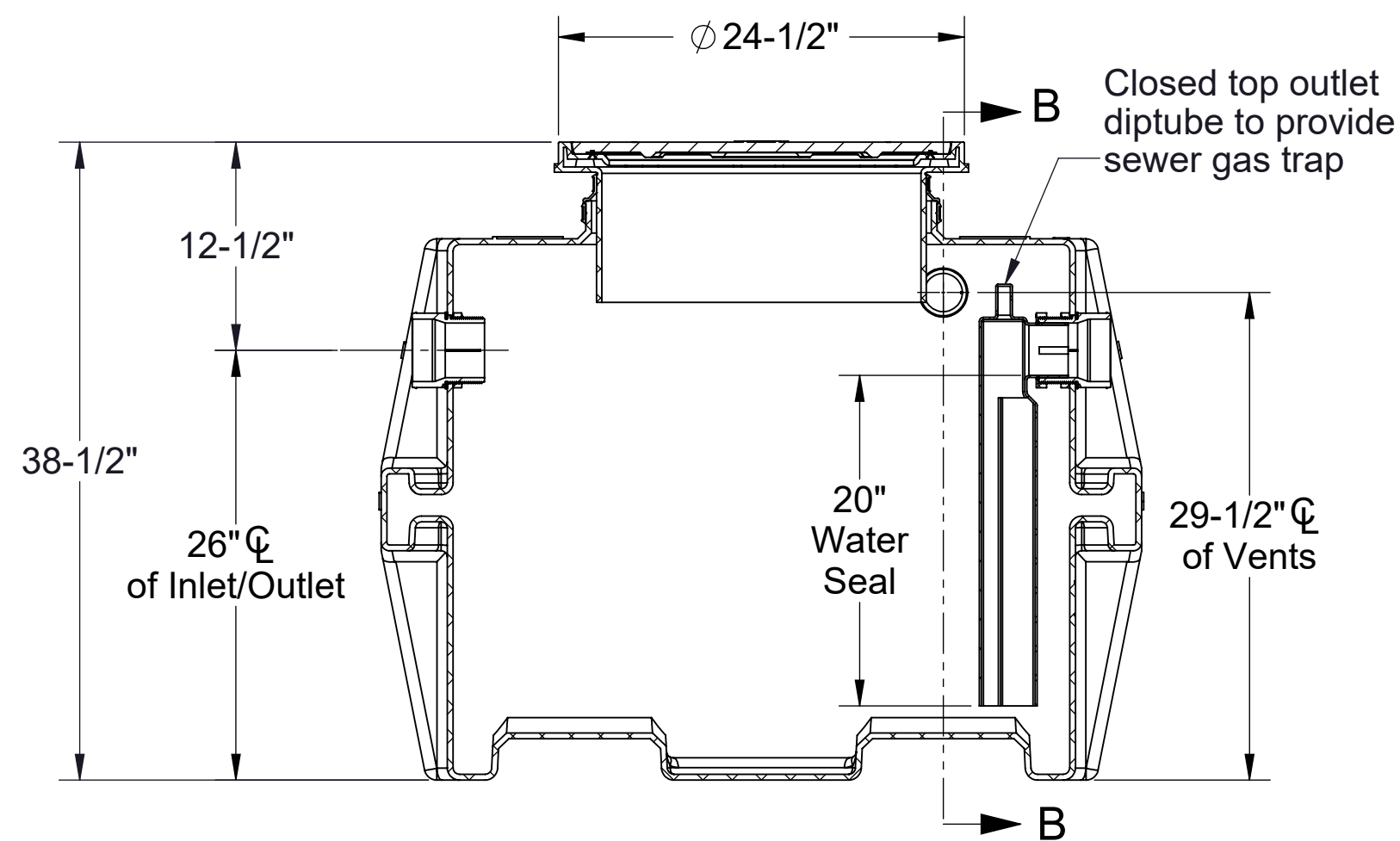

SECTION A-A

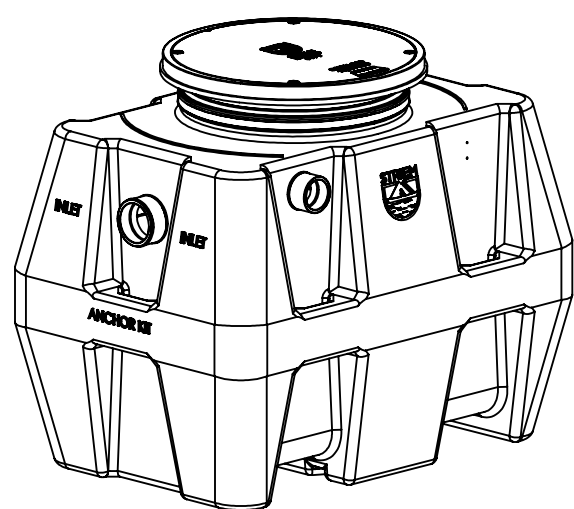

PROPRIETARY AND CONFIDENTIAL
 THE INFORMATION CONTAINED IN THIS DRAWING IS THE SOLE PROPERTY OF STRIEM, LLC.
 ANY REPRODUCTION IN PART OR AS A WHOLE WITHOUT THE WRITTEN PERMISSION OF STRIEM, LLC. IS PROHIBITED.

OPTIONS

Riser Options

From Factory: Up to 5"

- Up to 24": **SR24**
- Up to 39": **LR24**
- Up to 43": **SR24 (2)**
- Up to 58": **SR24 + LR24**
- Up to 72": **LR24 (2)**

- OR -

- CPRK:** 11" - 72" (See specification for more detail.)

Additional Options

- C24-HP:** H2O Rated Pickable Cast Iron Cover
- HDK-2:** High Water Table Hold Down Kit
- SS:** Slick Stick™ Oil Monitoring Solution*

*Monitoring system will raise cover by 3"

MODEL NUMBER: FLI-125

DESCRIPTION:
 110 GALLON POLYETHYLENE
 FLAMMABLE LIQUID INTERCEPTOR,
 UNRATED

DWG BY: ENG **DATE:** 6/4/2024 **REV:** 1

SPECIFICATION SHEET

Striem
 Kansas City, KS
 Tel: 913-222-1500
 orders@striemco.com
 www.striemco.com

Made in the U.S.A

