

**SPECIFICATIONS**

1. 4" Plain End inlet/outlet, 3" Plain End vents, C24-H covers standard.
2. Liquid capacity: 262 gallons (35 cu.ft.).
3. Solids capacity: 95 gallons.
4. Flammable liquid capacity: 144 gallons.
5. Unit weight w/ standard covers: 225 lbs.; w/ cast iron covers: 345 lbs.
6. Maximum operating temperature 140°F continuous.

**NOTES**

1. For gravity drainage applications only.
2. Do not use for pressure applications.
3. Cover placement allows full access to tank for proper maintenance.
4. Narrow footprint allows clearance through doorways and down stairs.
5. Diptubes are removable to inspect/clean piping.

**ENGINEER SPECIFICATION GUIDE**

Striem flammable liquid interceptor model FLI-275 shall be lifetime guaranteed and made in the USA. Interceptor shall be constructed of polyethylene. Interceptor shall be manufactured for above- or below-grade installation. Field-adjustable riser system is available as an option to bring manhole covers to grade. Interceptor liquid holding capacity shall be 262 gallons and flammable liquid capacity shall be 144 gallons. Solids capacity shall be 95 gallons. Covers shall provide water/gas-tight seal and have a maximum 16,000 lbs. load capacity.

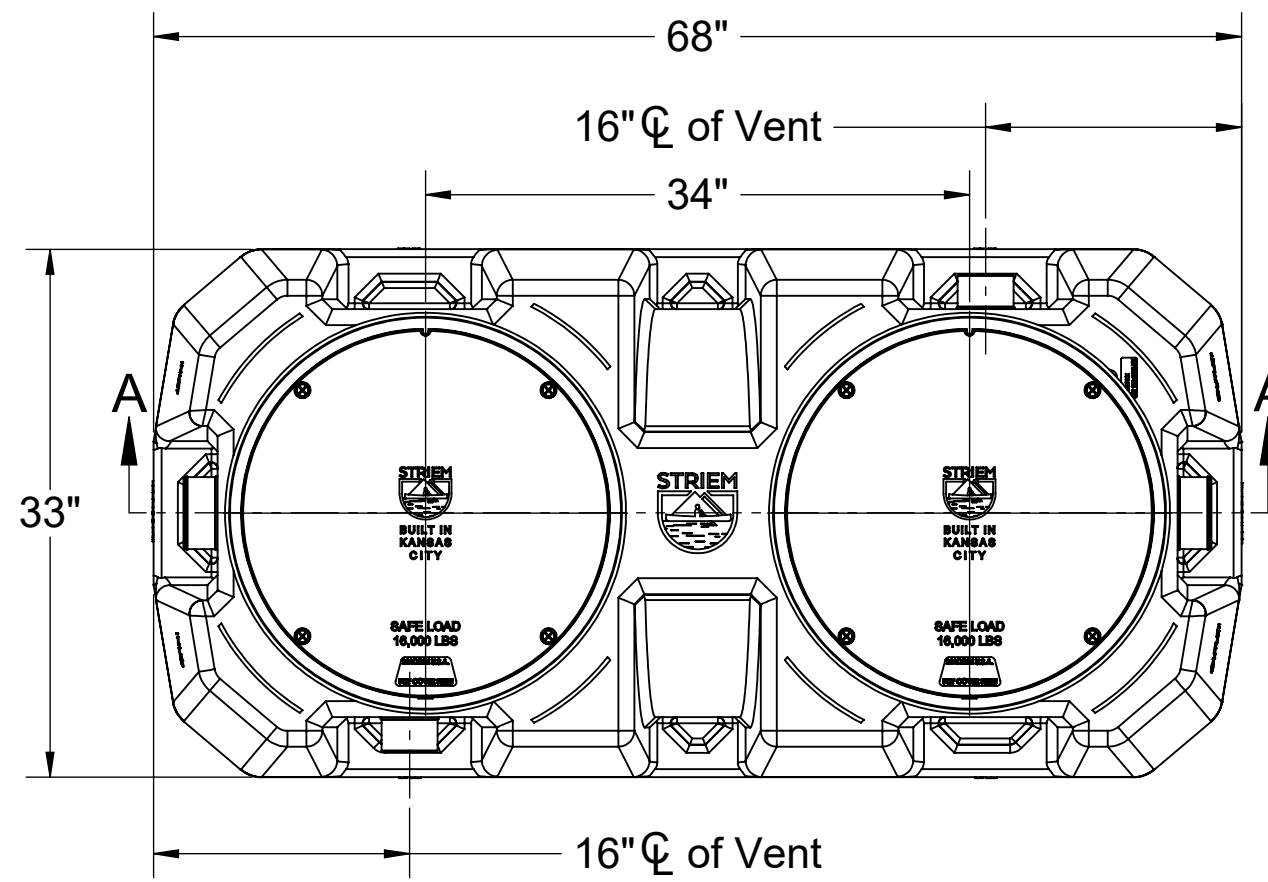

**TOP VIEW**

OPTIONS	
<b>Connection Options (Plain End Only)</b>	
<b>Inlet / Outlet</b>	
<input type="checkbox"/> 4"	
<input type="checkbox"/> 6"	
<b>Riser Options</b>	
<b>From Factory: Up to 5"</b>	
<input type="checkbox"/> Up to 24": <b>SR24</b> (2)	
<input type="checkbox"/> Up to 39": <b>LR24</b> (2)	
<input type="checkbox"/> Up to 43": <b>SR24</b> (4)	
<input type="checkbox"/> Up to 58": <b>SR24</b> (2) + <b>LR24</b> (2)	
<input type="checkbox"/> Up to 72": <b>LR24</b> (4)	
<input type="checkbox"/> Up to 90": <b>SR24</b> (2) + <b>LR24</b> (4)	
<b>- OR -</b>	
<input type="checkbox"/> <b>CPRK</b> (2): 11" - 90" (See specification for more detail.)	
<b>Additional Options</b>	
<input type="checkbox"/> <b>C24-HP</b> (2): H2O Rated Pickable Cast Iron Covers	
<input type="checkbox"/> <b>HDK-2</b> : High Water Table Hold Down Kit	
<input type="checkbox"/> <b>SS</b> : Slick Stick™ Oil Level Monitoring Solution**	
**Monitoring system will raise covers by 3"	

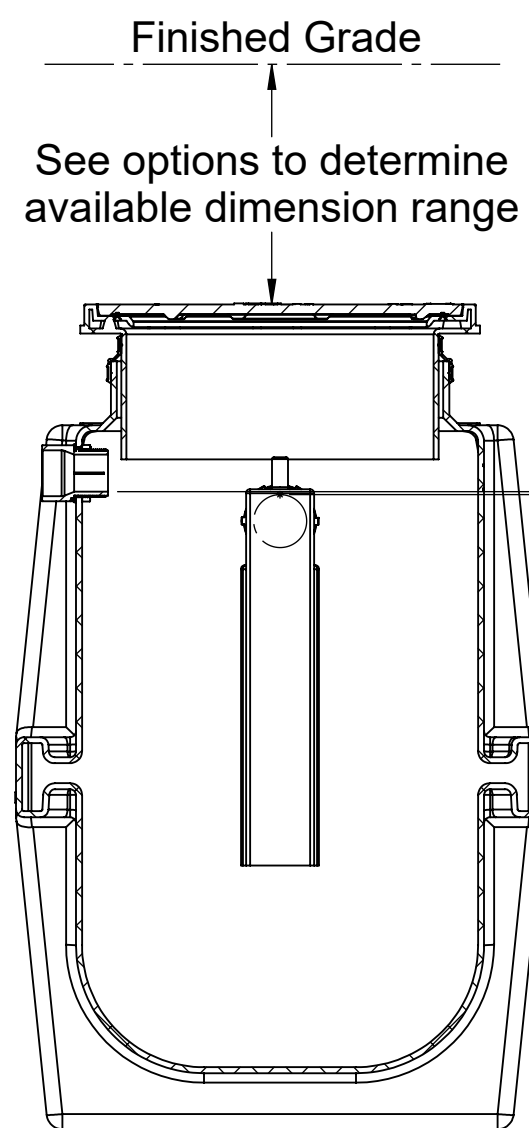

**SECTION B-B**

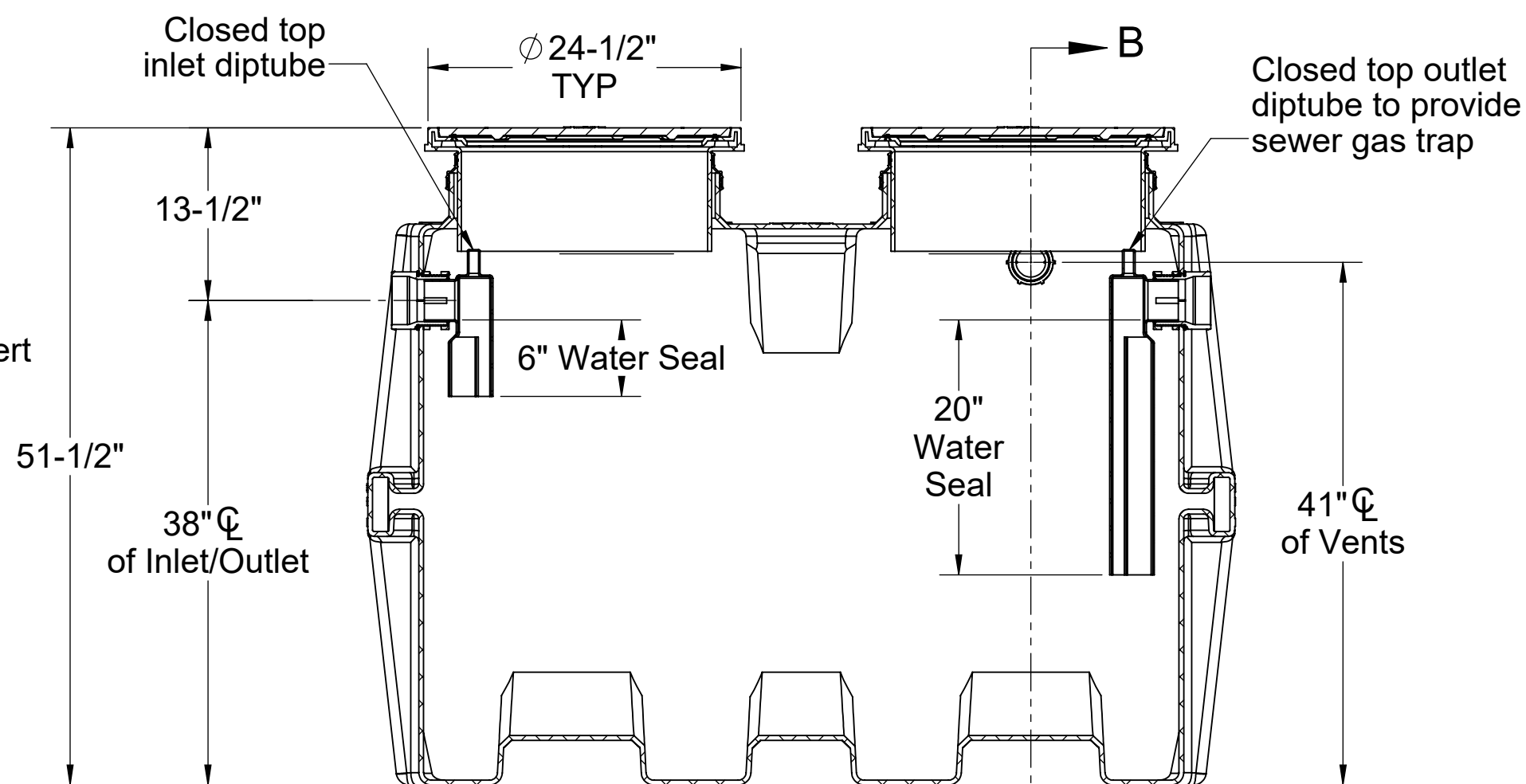

**SECTION A-A**

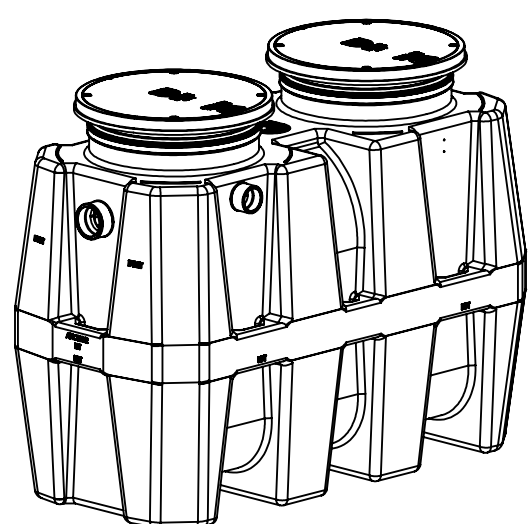

**PROPRIETARY AND CONFIDENTIAL**  
THE INFORMATION CONTAINED IN THIS DRAWING IS THE SOLE PROPERTY OF STRIEM, LLC. ANY REPRODUCTION IN PART OR AS A WHOLE WITHOUT THE WRITTEN PERMISSION OF STRIEM, LLC. IS PROHIBITED.

<b>MODEL NUMBER:</b>	FLI-275
<b>DESCRIPTION:</b>	262 GALLON POLYETHYLENE FLAMMABLE LIQUID INTERCEPTOR, UNRATED
<b>DWG BY:</b>	ENG
<b>DATE:</b>	6/4/2024
<b>REV:</b>	1

<b>SPECIFICATION SHEET</b>	
Striem Kansas City, KS Tel: 913-222-1500 orders@striemco.com www.striemco.com	
Made in the U.S.A	