

SPECIFICATIONS

1. 2" Plain End inlet/outlet, 2" Plain End vents.
2. Liquid holding capacity: 15 Gallons.
3. Unit weight: 30 lbs.
4. Cover rated at 450 lbs. when unit is installed above-grade and 2,500 lbs. when buried with SR16 riser.
5. Maximum operating temperature 140°F continuous.

NOTES

1. For gravity drainage applications only.
2. Do not use for pressure applications.
3. Cover placement allows full access to tank for proper maintenance.
4. Diptube is removable to inspect/clean piping.
5. For above- or below-grade installation.

ENGINEER SPECIFICATION GUIDE

Striem Lab Basin™ neutralization tank model LB-15 shall be lifetime guaranteed and made in the USA. It shall be constructed of polyethylene with 3/8" nominal wall thickness. Tank shall be manufactured for above- or below-grade installation. Field-adjustable riser system is available as an option to bring cover to grade. Tank liquid holding capacity shall be 15 gallons. Cover shall provide water/gas-tight seal and have a maximum 450 lbs. load capacity when unit is installed above-grade, and 2,500 lbs. when buried with SR16 riser.

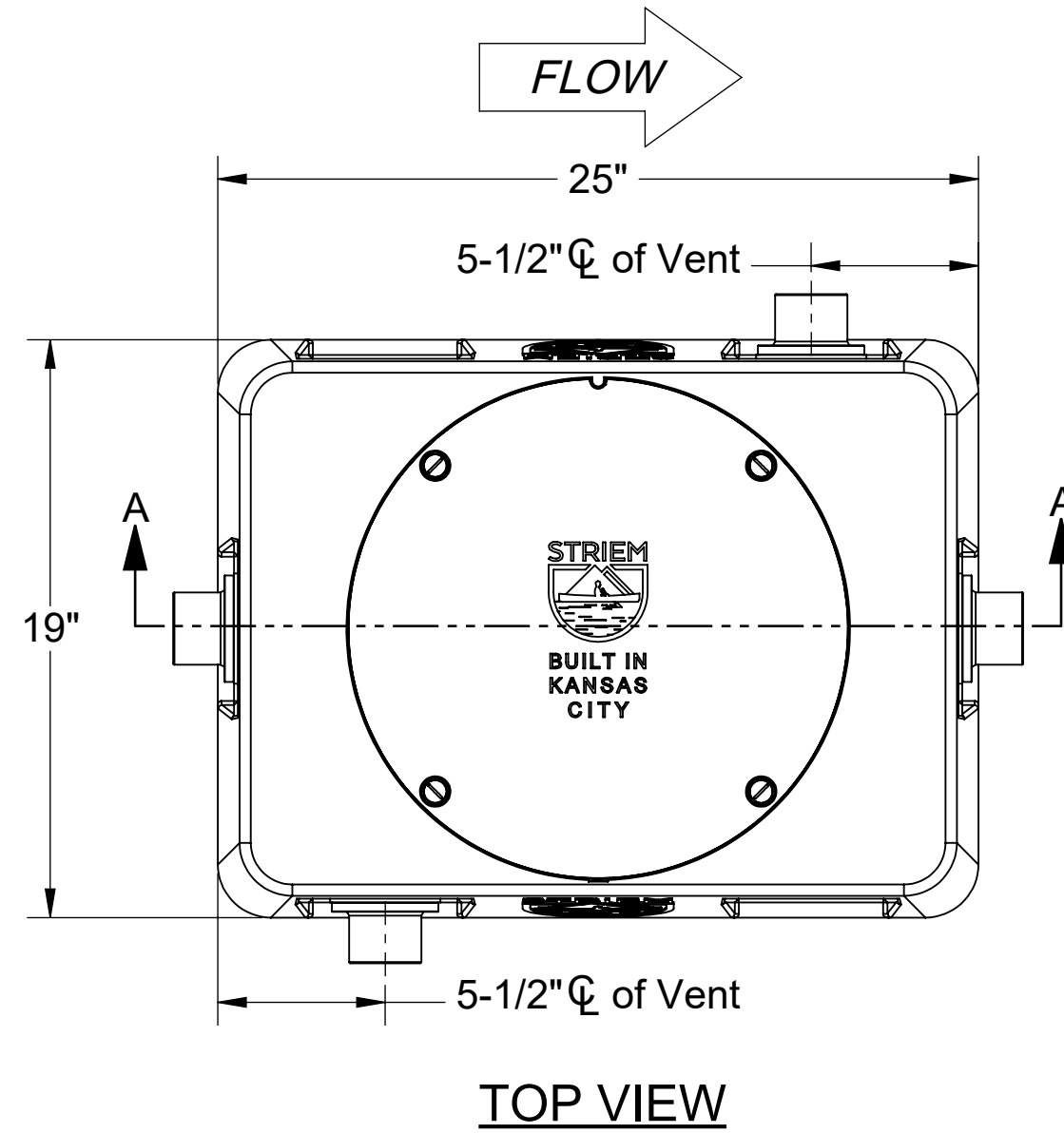

TOP VIEW

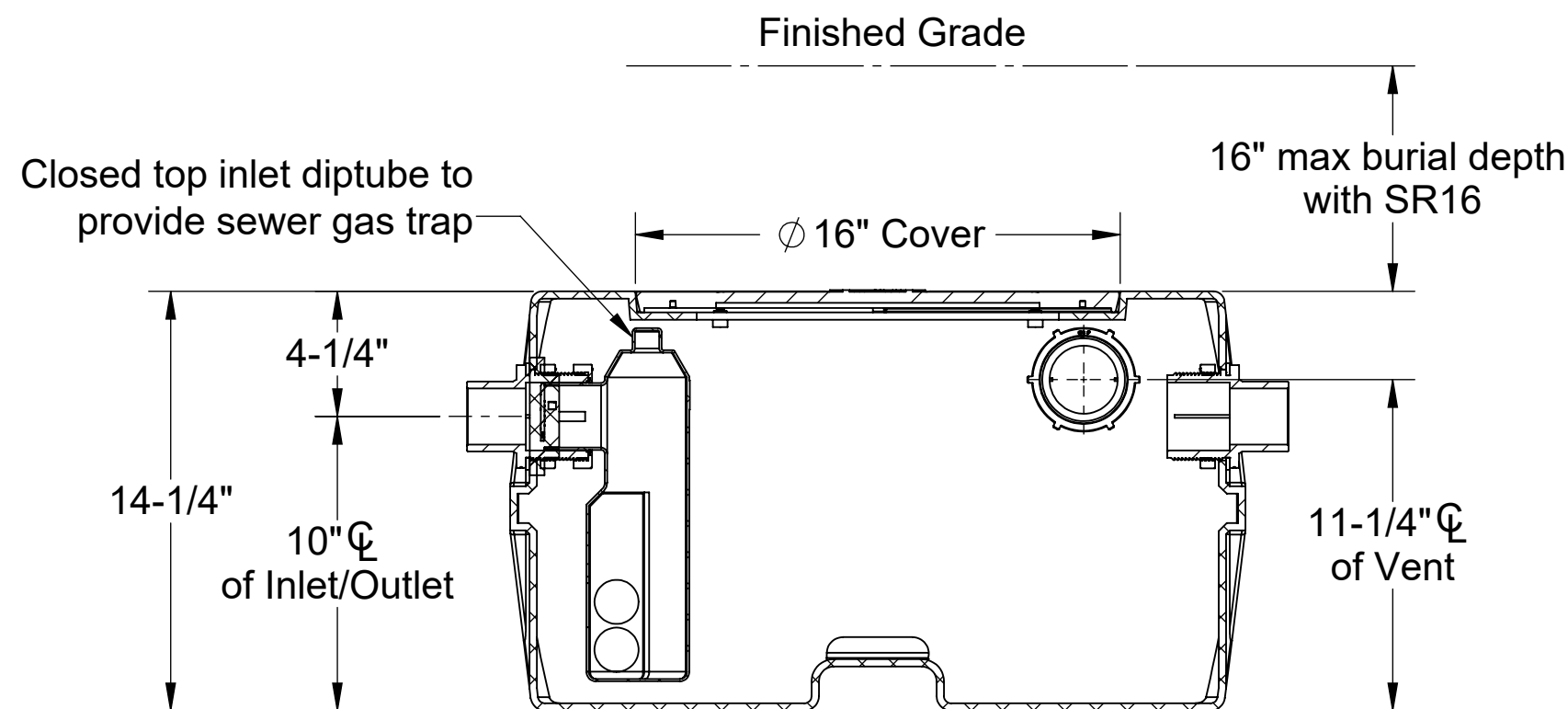

SECTION A-A

**PO IS NON-CANCELABLE
ORDER IS NON-RETURNABLE**

Signature of Approval: _____
 Company: _____
 Date of Approval: _____
 Specifying Engineer: _____
 Engineering Firm: _____

PROPRIETARY AND CONFIDENTIAL
 THE INFORMATION CONTAINED IN THIS DRAWING IS THE SOLE PROPERTY OF STRIEM, LLC.
 ANY REPRODUCTION IN PART OR AS A WHOLE WITHOUT THE WRITTEN PERMISSION OF STRIEM, LLC. IS PROHIBITED.

MODEL NUMBER:	LB-15
DESCRIPTION:	LAB BASIN SERIES POLYETHYLENE CHEMICAL WASTE TANK
DWG BY:	ENG
DATE:	12/27/2022
REV:	0

Directions: Select options & submit signed with purchase order.

Connections

- | | |
|--|-----------------------------|
| Inlet / Outlet | Size |
| <input type="checkbox"/> Plain End | <input type="checkbox"/> 2" |
| <input type="checkbox"/> Female Thread | <input type="checkbox"/> 3" |
| Vent | Size |
| <input type="checkbox"/> Plain End | <input type="checkbox"/> 2" |
| | <input type="checkbox"/> 3" |

Diptube Location

- Diptube at:** Inlet Outlet Both (Ohio Code)
 (Provided on inlet if not specified)

Additional Options

- SR16:** 4"-16" 16 Series Riser
 - CC-1:** Command Center pH Monitoring Package
 - SPK-A:** Above Grade Sensor Placement Kit*
 - SPK-B:** Below Grade Sensor Placement Kit*
 - Limestone:** 90%+ Calcium Carbonate (200 lbs.)
- *Required with CC-1

SPECIFICATION SHEET

Striem
 3100 Brinkerhoff
 Kansas City, KS 66115
 Tel: 913-222-1500
 orders@striemco.com
 www.striemco.com

Made in the U.S.A

