

SPECIFICATIONS

1. Liquid holding capacity: 15 Gallons
2. Unit weight w/std. cover: 30 Pounds
3. Standard cover handles 450 lbs. when unit is installed above-grade and 2,500 lbs. when buried with SR16 riser.
4. Maximum operating temperature 140°F continuous.

NOTES

1. For gravity drainage applications only. Do not use for pressure applications.
2. 3/8" thick seamless medium density polyethylene walls.
3. Cover placement allows full access to tank for proper maintenance.
4. Engineered inlet diffuser is removable to inspect/clean piping.
5. For on the-floor or buried applications.

ENGINEER SPECIFICATION GUIDE

Striem Lab Basin™ neutralization tank model LB-15 shall be lifetime guaranteed and Made in USA of seamless, rotationally-molded polyethylene with minimum 3/8" uniform wall thickness. Tank shall be furnished with inlets, outlets, (2) vent connections, cover, riser system, monitoring equipment and other modifications per jobsite-specific conditions and per engineer's specification. Cover shall provide water/gas-tight seal and have a maximum 450 lbs load capacity when unit is installed above-grade, and 2,500 lbs when buried with SR16 riser.

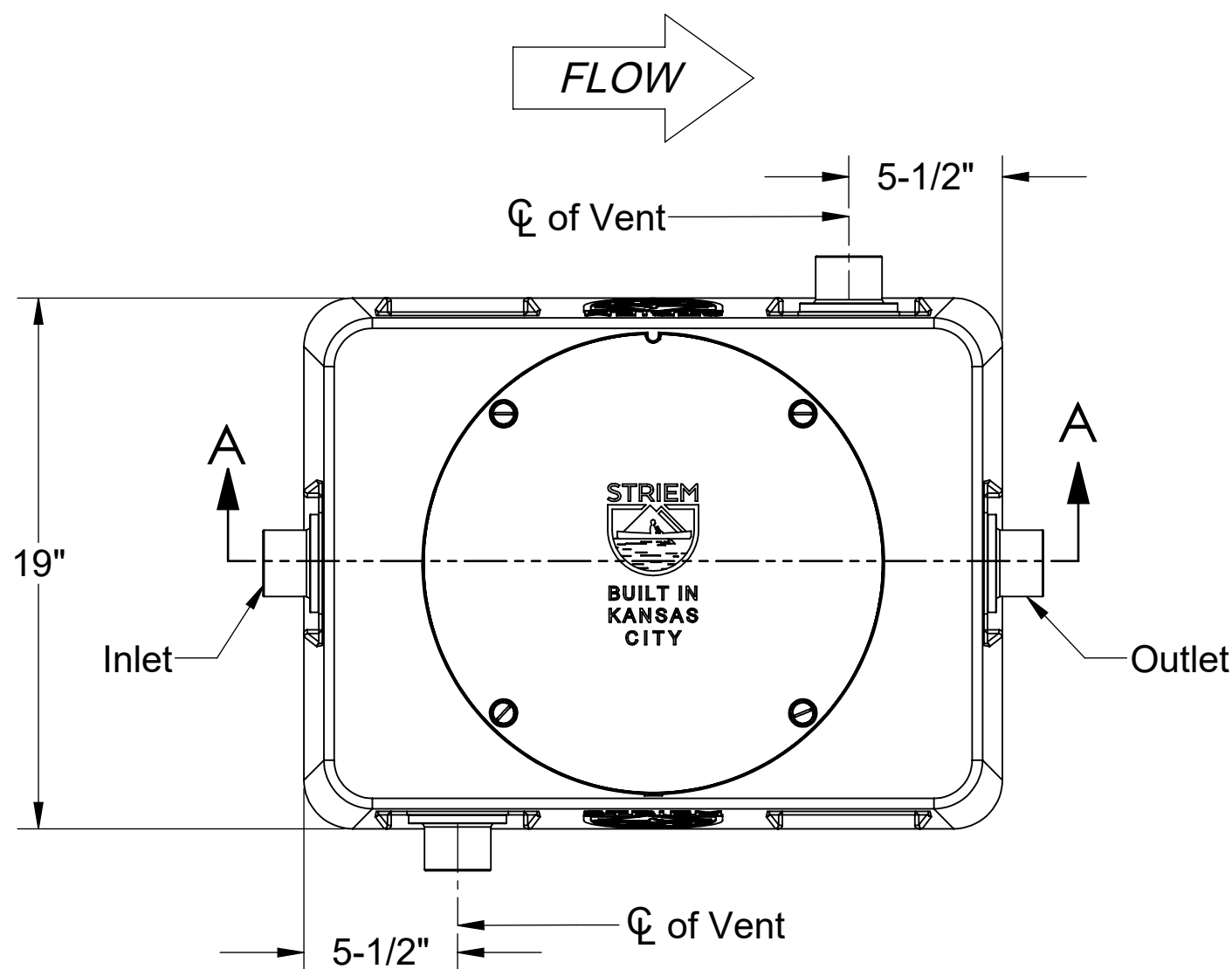

TOP VIEW

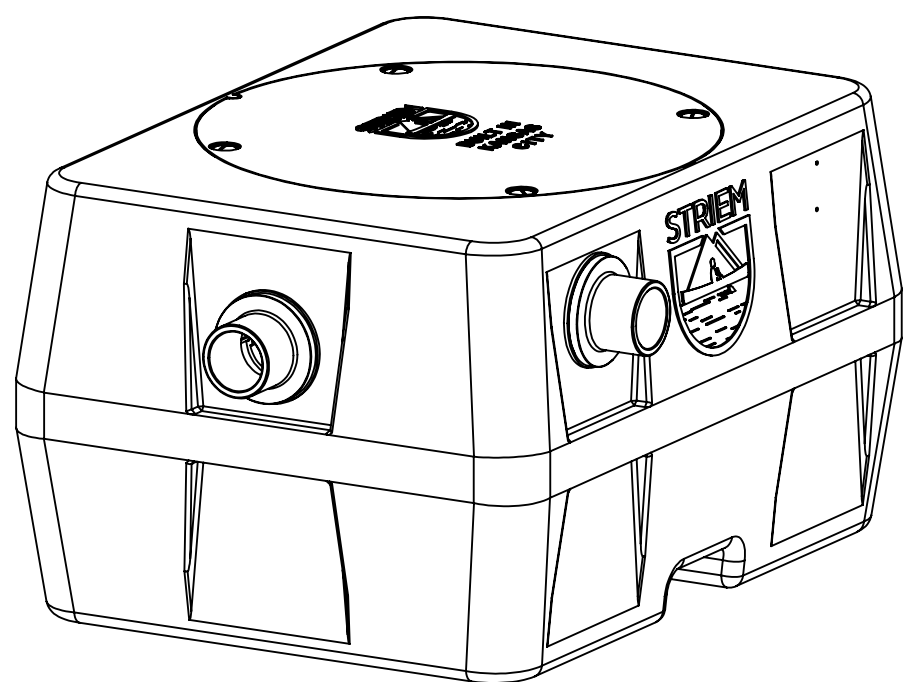

Closed top inlet diffuser to provide sewer gas trap

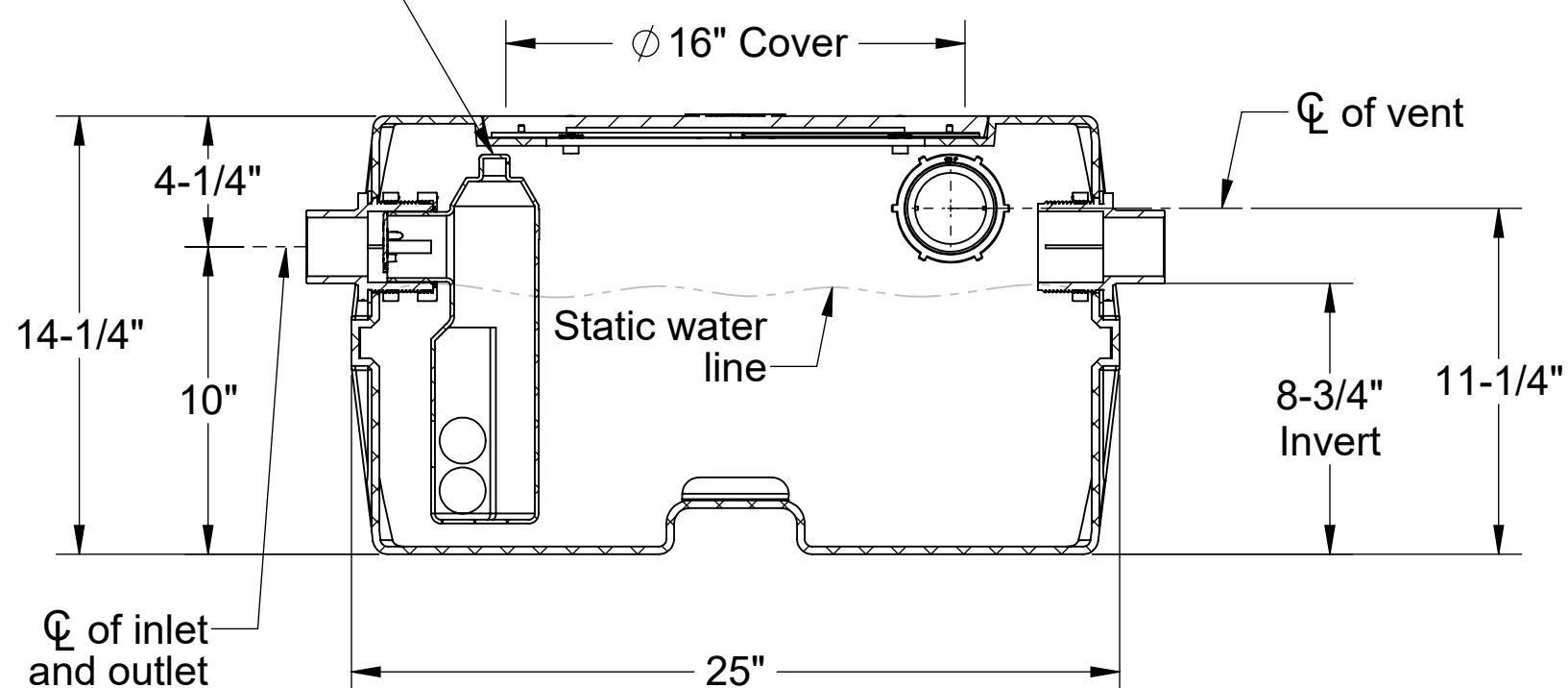

SECTION "A-A"

Directions: Complete steps 1-3 and submit signed with purchase order.

1. Choose Connection Types.

- | | |
|--|-----------------------------|
| Inlet / Outlet | Size |
| <input type="checkbox"/> Plain End | <input type="checkbox"/> 2" |
| <input type="checkbox"/> Female Thread | <input type="checkbox"/> 3" |
| <input type="checkbox"/> Flanged | |

- | | |
|-------------|-----------------------------|
| Vent | Size |
| Plain End | <input type="checkbox"/> 2" |
| | <input type="checkbox"/> 3" |

2. Diptube Location.

- Diptube at:** Inlet Outlet Both (Ohio Code)
(Provided on inlet if not specified)

3. Additional Options.

- SR16:** 4"-16" 16 Series Riser
- CC-1:** Command Center pH Monitoring Package
 - SPK-A:** Above Grade Sensor Placement Kit*
 - SPK-B:** Below Grade Sensor Placement Kit*
- 90%+ Calcium Carbonate Limestone (200 lbs.)

*Required with CC-1

Signature of Approval: _____
 Company: _____
 Date of Approval: _____
 Specifying Engineer: _____
 Engineering Firm: _____

MODEL NUMBER:	LB-15
DESCRIPTION:	LAB BASIN SERIES POLYETHYLENE CHEMICAL WASTE TANK
DWG BY: WLF	DATE: 2/24/22
REV: 0	ECO:

SPECIFICATION SHEET

Striem
 3100 Brinkerhoff
 Kansas City, KS 66115
 Tel: 913-222-1500
 orders@striemco.com
 www.striemco.com



Made in the U.S.A

PROPRIETARY AND CONFIDENTIAL

THE INFORMATION CONTAINED IN THIS DRAWING IS THE SOLE PROPERTY OF STRIEM, LLC. ANY REPRODUCTION IN PART OR AS A WHOLE WITHOUT THE WRITTEN PERMISSION OF STRIEM, LLC. IS PROHIBITED.