

SPECIFICATIONS

1. 4" Plain End inlet/outlet, 2" Plain End vents, C24-M cover standard.
2. Liquid holding capacity: 57 Gallons.
3. Unit weight: 93 lbs.
4. Maximum operating temperature 140°F continuous.

NOTES

1. For gravity drainage applications only.
2. Do not use for pressure applications.
3. Cover placement allows full access to tank for proper maintenance.
4. Diptube is removable to inspect/clean piping.

ENGINEER SPECIFICATION GUIDE

Striem neutralization tank model LB-50 shall be lifetime guaranteed and made in the USA. Tank shall be constructed of polyethylene. Tank shall be manufactured for above- or below-grade installation. Field-adjustable riser system is available as an option to bring manhole cover to grade. Tank liquid holding capacity shall be 57 gallons. Cover shall provide water/gas-tight seal and have a maximum 2,000 lbs. load capacity.

THIRD PARTY STRUCTURAL ANALYSIS

The LB-50 has been structurally analyzed in accordance with the requirements of IBC 2012 and ASCE/SEI 7 for direct burial. The maximum burial depth and backfill material are specified in our installation instructions. The structural design has been reviewed and sealed by a professional engineer registered in the state of California. A sealed structural analysis report is available upon request.

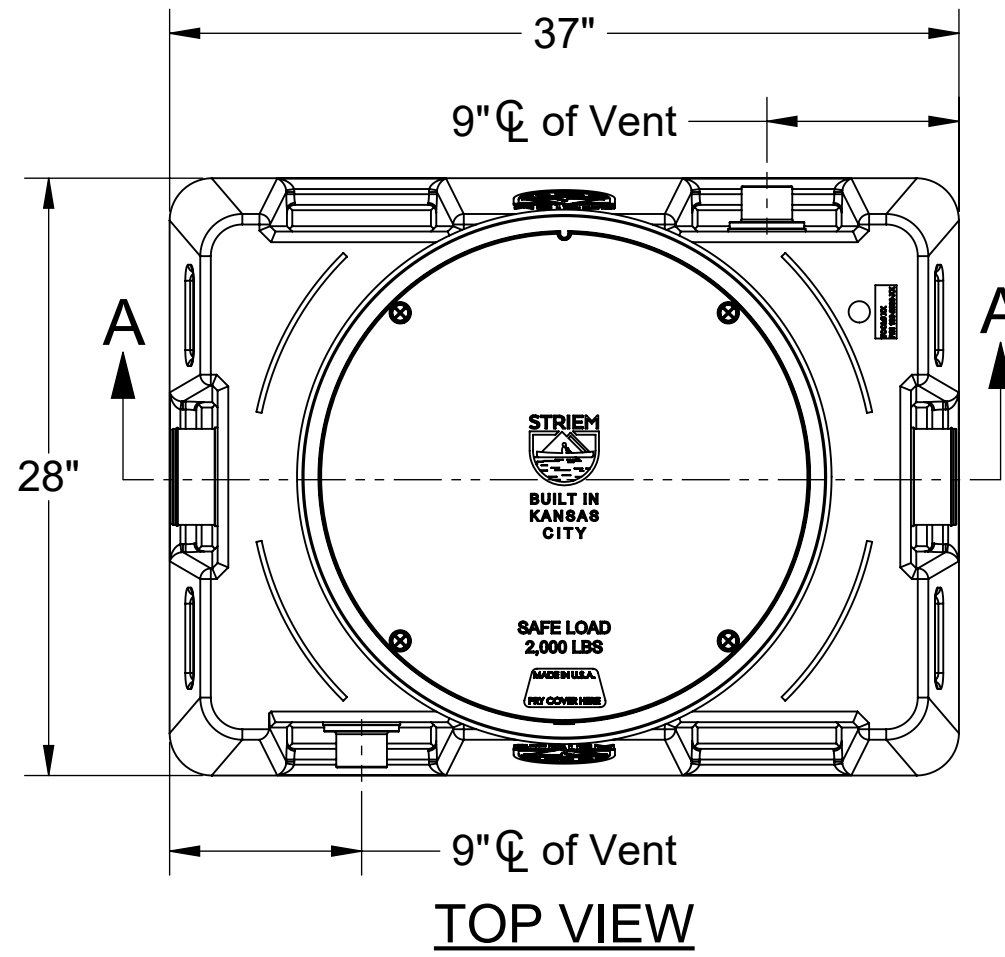

OPTIONS	
Connection Options (Plain End Only)	
Inlet / Outlet	
<input type="checkbox"/>	2"
<input type="checkbox"/>	3"
<input type="checkbox"/>	4"
Riser Options	
From Factory: 0" - 5"	
<input type="checkbox"/>	Up to 24": SR24
<input type="checkbox"/>	Up to 39": LR24
Additional Options	
<input type="checkbox"/>	HDK-2: High Water Table Hold Down Kit
<input type="checkbox"/>	C24-H: Highway Rated Bolted Composite Cover
<input type="checkbox"/>	CC-1: Command Center pH Monitoring Package
<input type="checkbox"/>	SPK: Sensor Placement Kit*
<input type="checkbox"/>	Limestone: 90%+ Calcium Carbonate (650 lbs.)
*Required with CC-1	

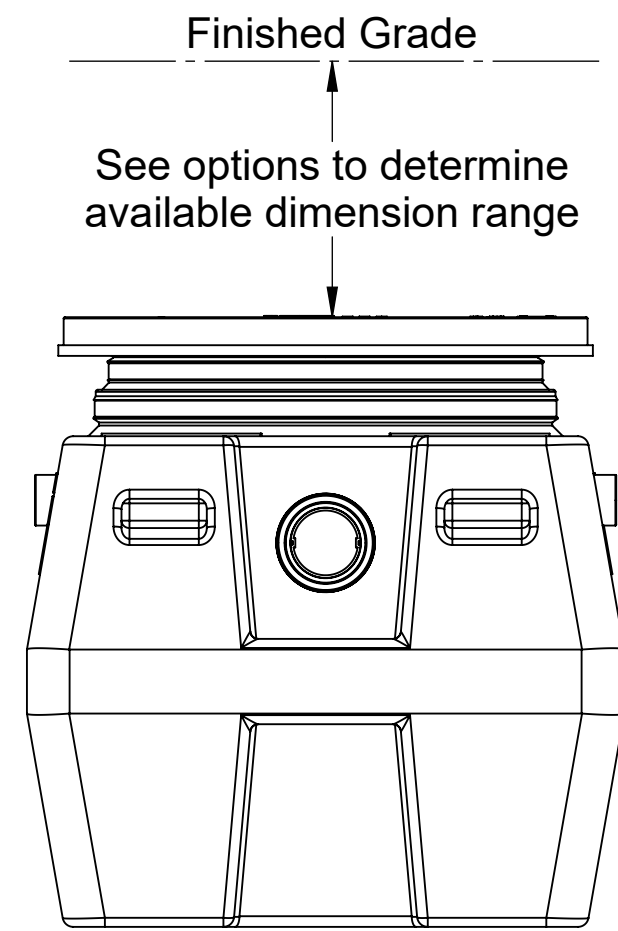

END VIEW

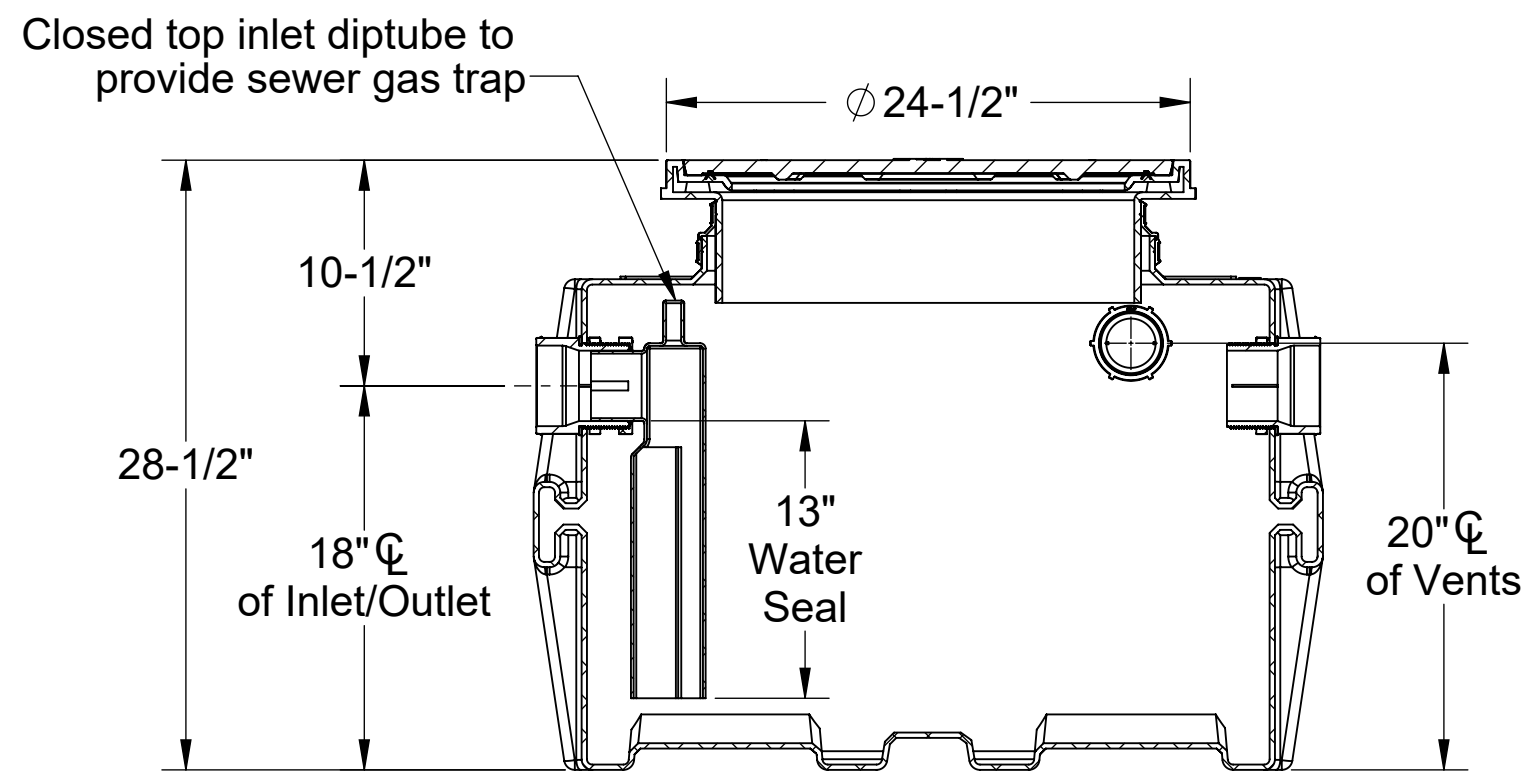

SECTION A-A

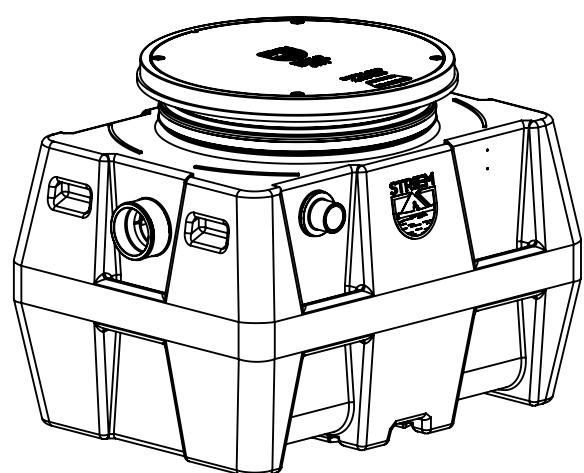

PROPRIETARY AND CONFIDENTIAL
THE INFORMATION CONTAINED IN THIS DRAWING IS THE SOLE PROPERTY OF STRRIEM, LLC. ANY REPRODUCTION IN PART OR AS A WHOLE WITHOUT THE WRITTEN PERMISSION OF STRRIEM, LLC. IS PROHIBITED.

MODEL NUMBER:	LB-50
DESCRIPTION:	LAB BASIN™ POLYETHYLENE NEUTRALIZATION TANK
DWG BY: ENG	DATE: 5/24/2024
REV: 1	

SPECIFICATION SHEET

Striem
Kansas City, KS
Tel: 913-222-1500
orders@striemco.com
www.striemco.com

Made in the U.S.A

