

SPECIFICATIONS

1. 6" Plain End inlet/outlet shown, 3" Plain End vents standard.
2. Liquid capacity: 750 gallons (100 cu. ft.).
3. Unit weight: 1073 lbs.
4. Maximum operating temperature 140°F continuous.

NOTES

1. For gravity drainage applications only.
2. Do not use for pressure applications.
3. Cover placement allows full access to tank for proper maintenance.
4. Lifting lug set for easy install.

ENGINEER SPECIFICATION GUIDE

Striem neutralization tank model LB-750 shall be lifetime guaranteed and made in the USA. Tank shall be constructed of polyethylene with 7/8" nominal wall thickness. Tank shall be manufactured for below-grade installation. Field-adjustable riser system is available as an option to bring manhole covers to grade. Tank liquid holding capacity shall be 750 gallons. Covers shall provide water/gas-tight seal and have a maximum 16,000 lbs. load capacity.

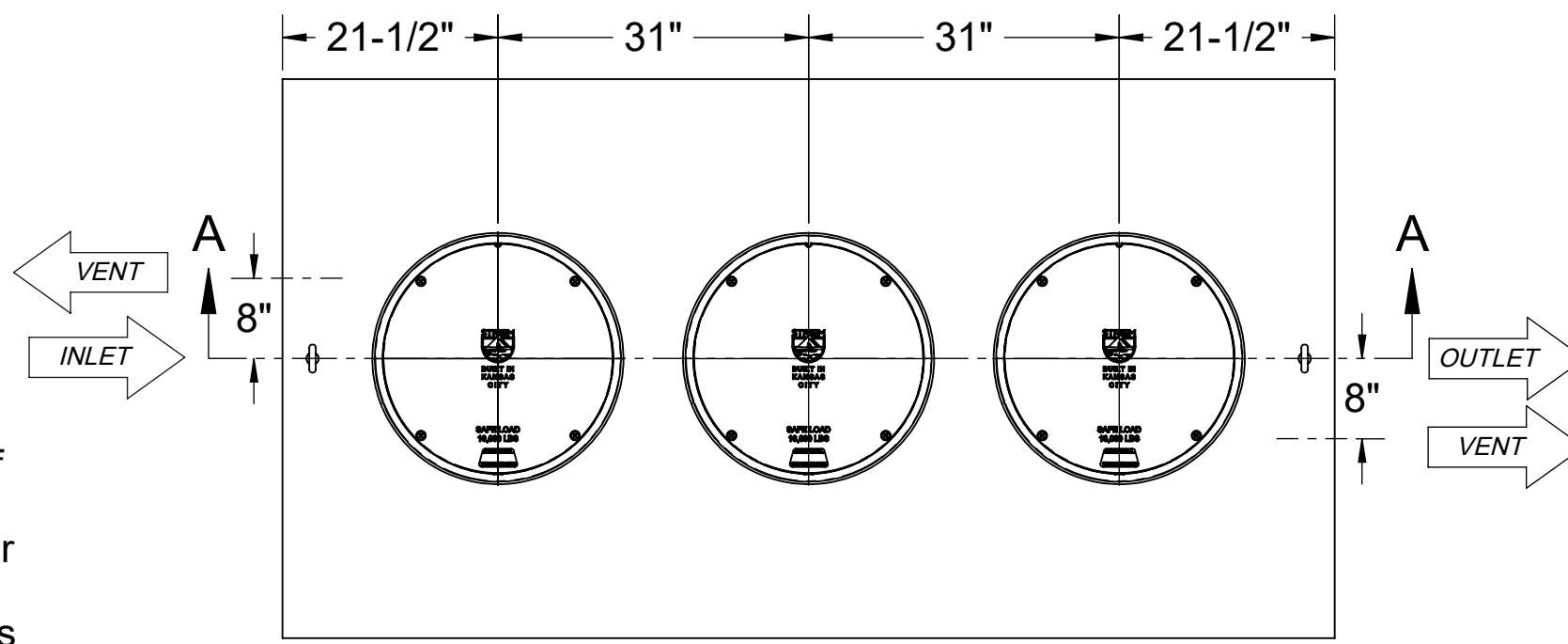

TOP VIEW

| OPTIONS | |
|---|-----------------------|
| Connection Options (Plain End Only) | |
| Inlet / Outlet | SELECTION REQUIRED |
| <input type="checkbox"/> 4" | |
| <input type="checkbox"/> 6" | |
| <input type="checkbox"/> 8" | |
| Riser Options | |
| From Factory: Up to 5" | |
| <input type="checkbox"/> Up to 24": SR24 (3) | |
| <input type="checkbox"/> Up to 39": LR24 (3) | |
| <input type="checkbox"/> Up to 43": SR24 (6) | |
| <input type="checkbox"/> Up to 58": SR24 (3) + LR24 (3) | |
| <input type="checkbox"/> Up to 72": LR24 (6) | |
| <input type="checkbox"/> Up to 90": SR24 (3) + LR24 (6) | |
| <input type="checkbox"/> Up to 106": LR24 (9) | |
| - OR - | |
| <input type="checkbox"/> CPRK (3): 11" - 106" (See specification for more detail.) | |
| Additional Options | |
| <input type="checkbox"/> CC-1 : Command Center pH Monitoring Package | |
| <input type="checkbox"/> SPK-A : Above-Grade Sensor Placement Kit* | |
| <input type="checkbox"/> SPK-B : Below-Grade Sensor Placement Kit* | |
| <input type="checkbox"/> HDK-4 : High Water Table Hold Down Kit | |
| <input type="checkbox"/> Limestone : 90%+ Calcium Carbonate (9,800 lbs.) | |
| *Required with CC-1 | |

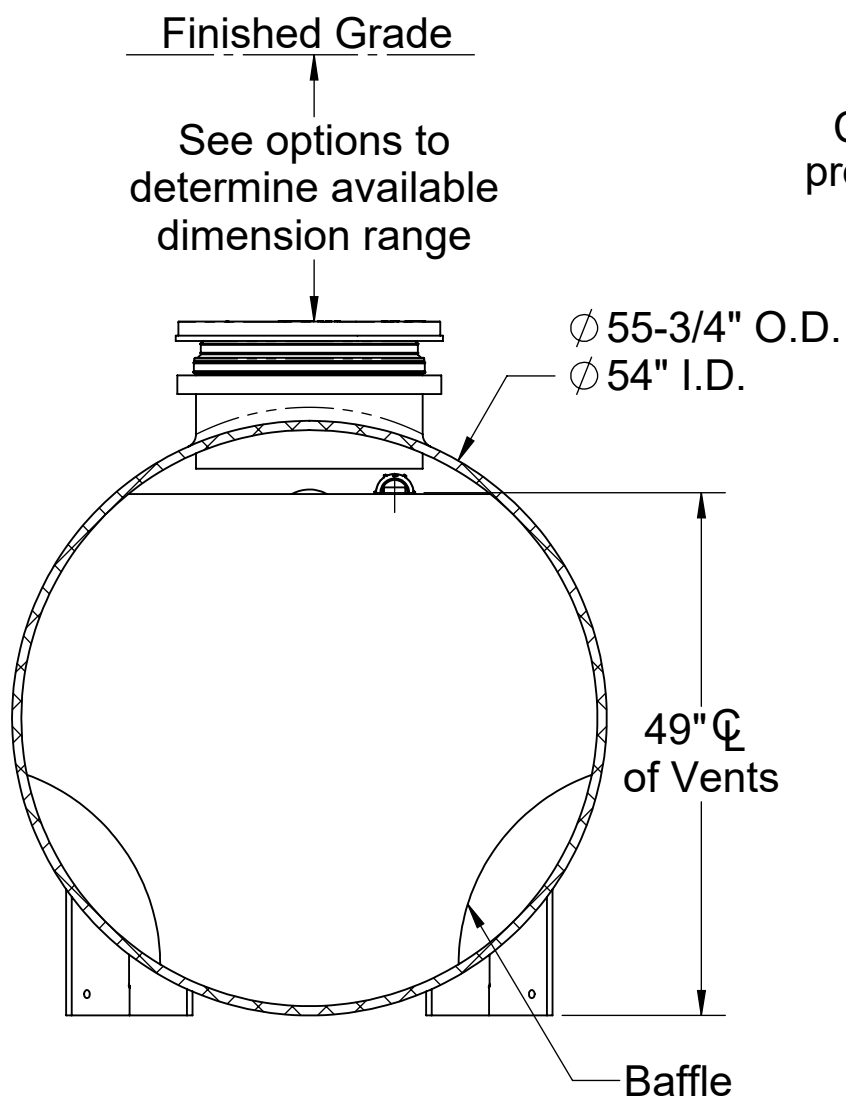

SECTION B-B

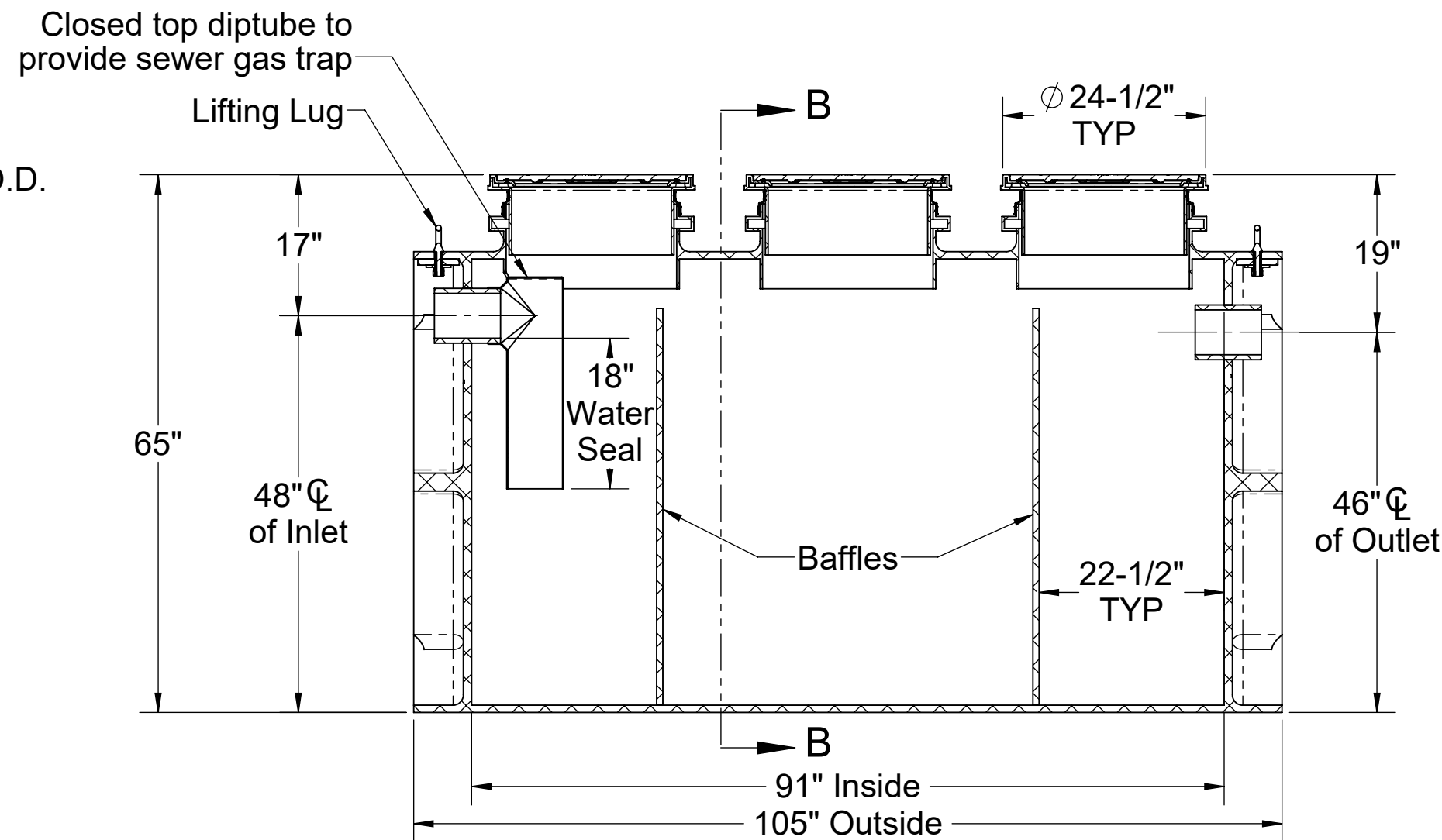

SECTION A-A

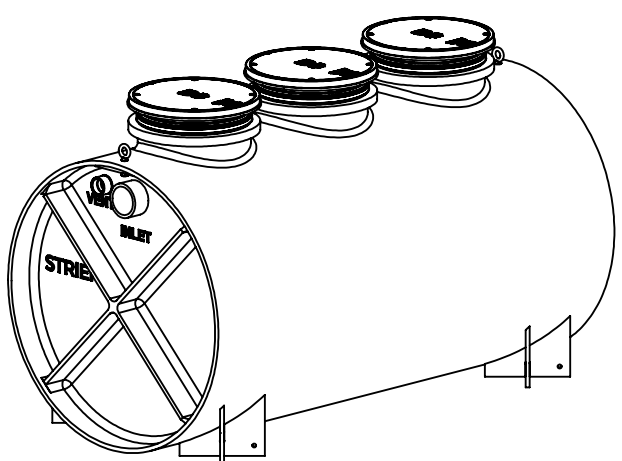

PO IS NON-CANCELABLE
ORDER IS NON-RETURNABLE

| | |
|----------------------|---|
| MODEL NUMBER: | LB-750 |
| DESCRIPTION: | LAB BASIN™ POLYETHYLENE NEUTRALIZATION TANK 750 GALLON CAPACITY |
| DWG BY: | ENG |
| DATE: | 8/22/2023 |
| REV: | 1 |

SPECIFICATION SHEET

Striem
Kansas City, KS
Tel: 913-222-1500
orders@striemco.com
www.striemco.com

Made in the U.S.A

