

**SPECIFICATIONS**

1. 3" Plain end vents standard.
2. Liquid capacity: 750 gallons (100 cu. ft.).
3. Unit weight: 1113 lbs.
4. Maximum operating temperature 140°F continuous.
5. Highway rated cover: 16,000 lb. load rating.

**NOTES**

1. For gravity drainage applications only. Do not use for pressure applications.
2. Cover placement allows full access to tank for proper maintenance.
3. Lifting lug set for easy install.
4. For below grade installation only.

**ENGINEER SPECIFICATION GUIDE**

Striem Lab Basin™ neutralization tank model LB-750 shall be lifetime guaranteed and Made in USA of High Density Polyethylene with minimum 7/8" uniform wall thickness. Tank shall be furnished with inlet, outlet, vent, cover, bracing, riser system, monitoring equipment and other modifications per jobsite-specific conditions and per engineer's specification.

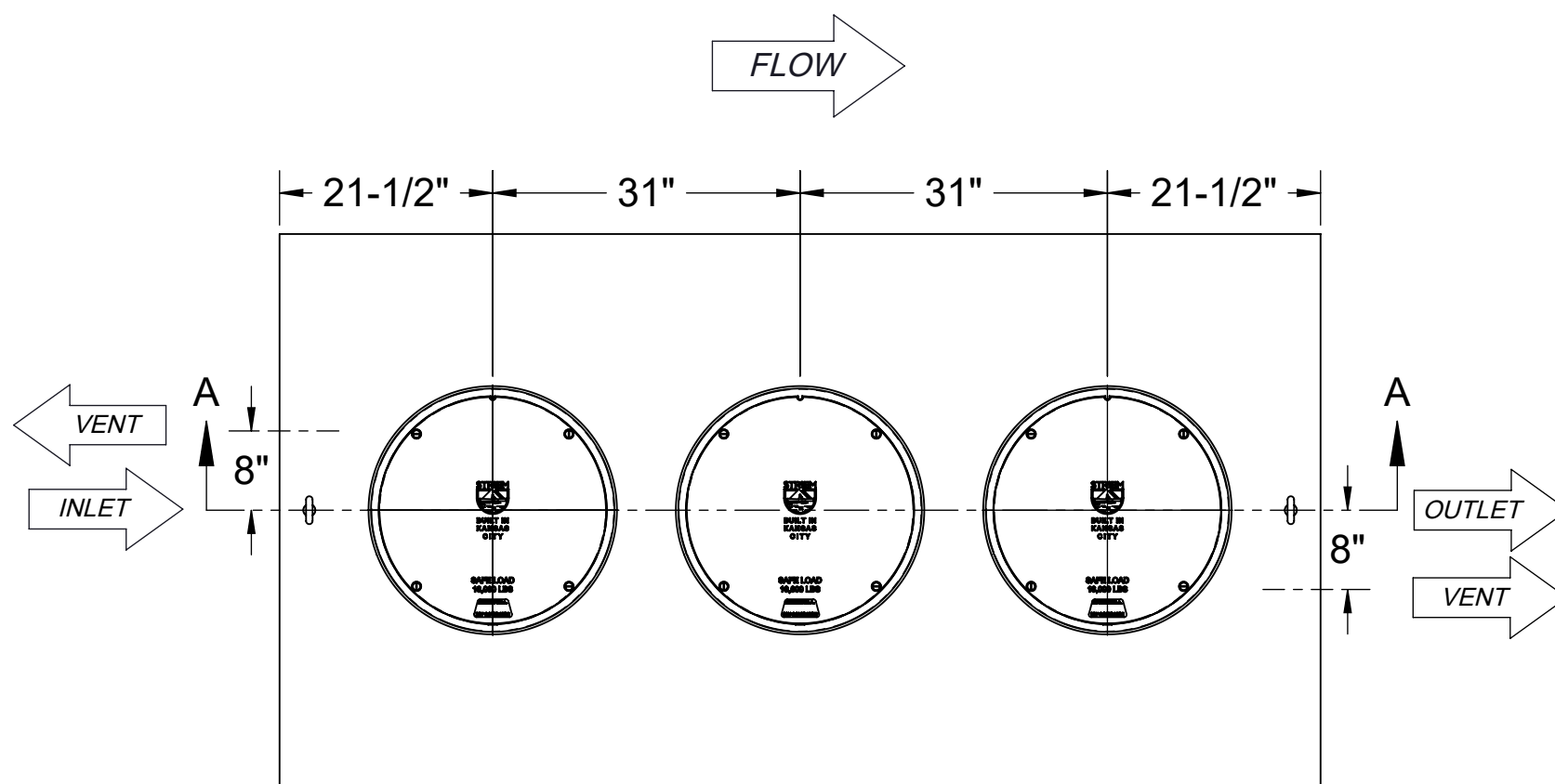

**TOP VIEW**

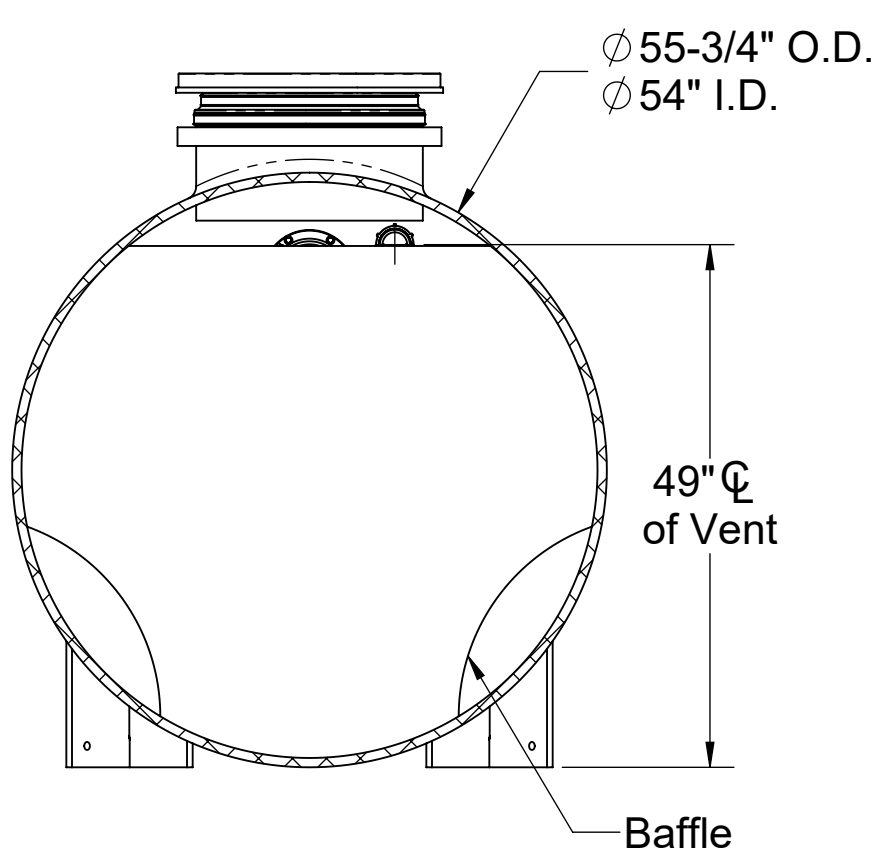

**SECTION B-B**

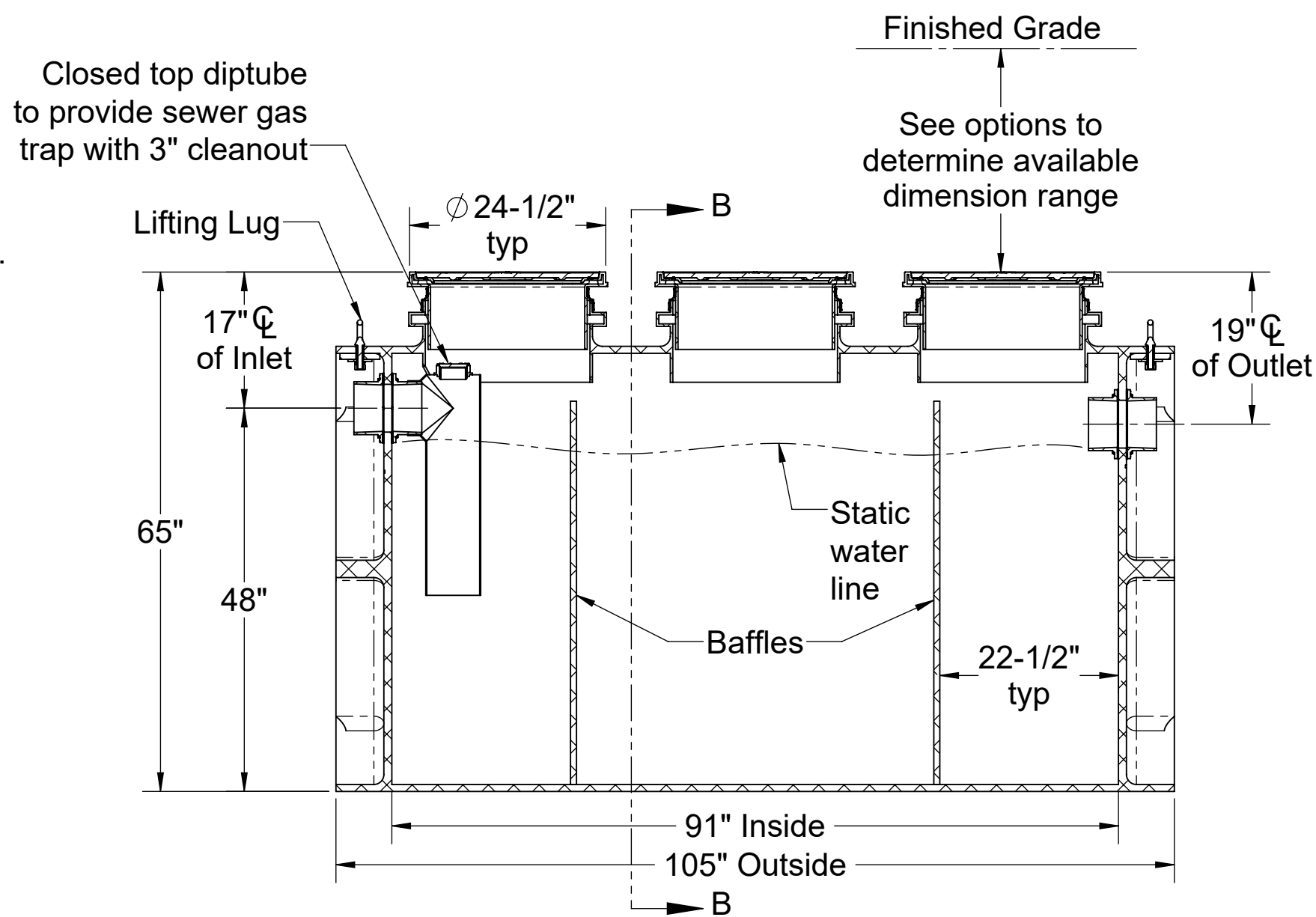

**SECTION A-A**

**Directions: Complete steps 1-4 and submit signed with purchase order.**

**1. Choose Connection Types.**

- |  |  |
|--|--|
| <b>Inlet / Outlet</b>                  | <b>Size</b>                                  |
| <input type="checkbox"/> Plain End     | <input type="checkbox"/> 4"                  |
| <input type="checkbox"/> Female Thread | <input type="checkbox"/> 6" (Plain End Only) |
|  | <input type="checkbox"/> 8" (Plain End Only) |

**2. Diptube Location.**

- Diptube at:**  Inlet  Outlet  Both (Ohio Code)  
(Provided on inlet if not specified)

**3. Riser Options.**

- Included : 0" - 5"**
- SR24** (3): 5" - 24"
  - LR24** (3): 24" - 39"
  - SR24** (6): 39" - 43"
  - SR24** (3) + **LR24** (3): 43" - 58"
  - LR24** (6): 58" - 72"
  - SR24** (3) + **LR24** (6): 72" - 90"
  - LR24** (9): 90" - 106"
- OR -**
- CPRK** (3): 11" - 106"
    - Corrugated Pipe Riser Kit.
    - Used in substitute of SR/LR riser options.
    - 18" diameter corrugated pipe by others.
    - See CPRK specification for more detail.

**4. Additional Options.**

- CC-1**: Command Center pH Monitoring Package
- SPK-A**: Above Grade Sensor Placement Kit\*
- SPK-B**: Below Grade Sensor Placement Kit\*
- HDK-4**: High Water Table Hold Down Kit
- 90%+ Calcium Carbonate Limestone (9,800 lbs.)

\*Required with CC-1

Signature of Approval: \_\_\_\_\_  
 Company: \_\_\_\_\_  
 Date of Approval: \_\_\_\_\_  
 Specifying Engineer: \_\_\_\_\_  
 Engineering Firm: \_\_\_\_\_

PO IS NON-CANCELABLE  
 ORDER IS NON-RETURNABLE

<b>MODEL NUMBER:</b>	LB-750
<b>DESCRIPTION:</b>	POLYETHYLENE NEUTRALIZATION TANK 750 GALLON CAPACITY
<b>DWG BY:</b>	MJ
<b>DATE:</b>	01/19/2022
<b>REV:</b>	0
<b>ECO:</b>	

**SPECIFICATION SHEET**

**Striem**  
 3100 Brinkerhoff  
 Kansas City, KS 66115  
 Tel: 913-222-1500  
 orders@striemco.com  
 www.striemco.com



Made in the U.S.A

THE INFORMATION CONTAINED IN THIS DRAWING IS THE SOLE PROPERTY OF STRIEM, LLC. ANY REPRODUCTION IN PART OR AS A WHOLE WITHOUT THE WRITTEN PERMISSION OF STRIEM, LLC. IS PROHIBITED.