

SPECIFICATIONS

1. 4" Plain End inlet/outlet; 4" Plain End vents.
2. Max flow rate: 100 GPM.
3. Capacities: Liquid: 250 gal. (33.4 cu. ft.); Oil: 50 gal.; Sand: 160 gal.
4. Unit weight with composite covers: 225 lbs.; with cast iron covers: 345 lbs.
5. Maximum operating temperature 140°F continuous.
6. Highway rated covers: 16,000 lb. capacity.

NOTES

1. For gravity drainage applications only. Do not use for pressure applications.
2. Seamless medium density polyethylene tank.
3. Unit supplied with built-in adapter for up to 5" of adjustability. Additional riser(s) available for deeper burial depth.
4. Cover placement allows full access to tank for proper maintenance.
5. Narrow footprint allows clearance through doorways and down stairs.
6. Engineered inlet and outlet diffusers are removable to inspect/clean piping.
7. For on the-floor or buried applications.

ENGINEER SPECIFICATION GUIDE

Striem Oil Reserve™ oil/sand separator model OS-100-OMAHA shall be lifetime guaranteed and made in USA of seamless, rotationally-molded polyethylene. Separator shall be furnished for above or below grade installation, with field adjustable riser system, and (2) vent connections. Separator flow rate shall be 100 GPM. Separator oil capacity shall be 50 gallons. Sand capacity shall be 160 gallons. Covers shall provide water/gas-tight seal and have a maximum 16,000 lbs load capacity.

THIRD PARTY STRUCTURAL ANALYSIS

The OS-100-OMAHA has been structurally analyzed in accordance with the requirements of IBC 2012 and ASCE/SEI 7 for direct burial. The maximum burial depth and backfill material are specified in our installation instructions. The structural design has been reviewed and sealed by a professional engineer registered in the state of California. A sealed structural analysis report is available upon request.

OPTIONS

- 4M:** 4" Male Thread Inlet / Outlet
- C24-HP (2):** H2O Rated Pickable Cast Iron Covers
- CC24 (2):** Integral Membrane Clamping Collar Kit
- CS3:** Clean Sweep Coalescing Media (single)
- CS6:** Clean Sweep Coalescing Media (double)
- HDK-2:** High Water Anchor Kit

RISER OPTIONS

- SR24 (2):** 5"-24"
- LR24 (2):** 24"-39"
- SR24 (4):** 39"-43"
- SR24 (2) + LR24 (2):** 43"-58"
- LR24 (4):** 58"-72"
- SR24 (2) + LR24 (4):** 72"-90"

-OR-

- CPRK (2):** 11" - 90"
 - Corrugated Pipe Riser Kit.
 - 18" diameter corrugated pipe by others.
 - Used in substitute of SR/LR riser options
 - See CPRK specification for more detail.

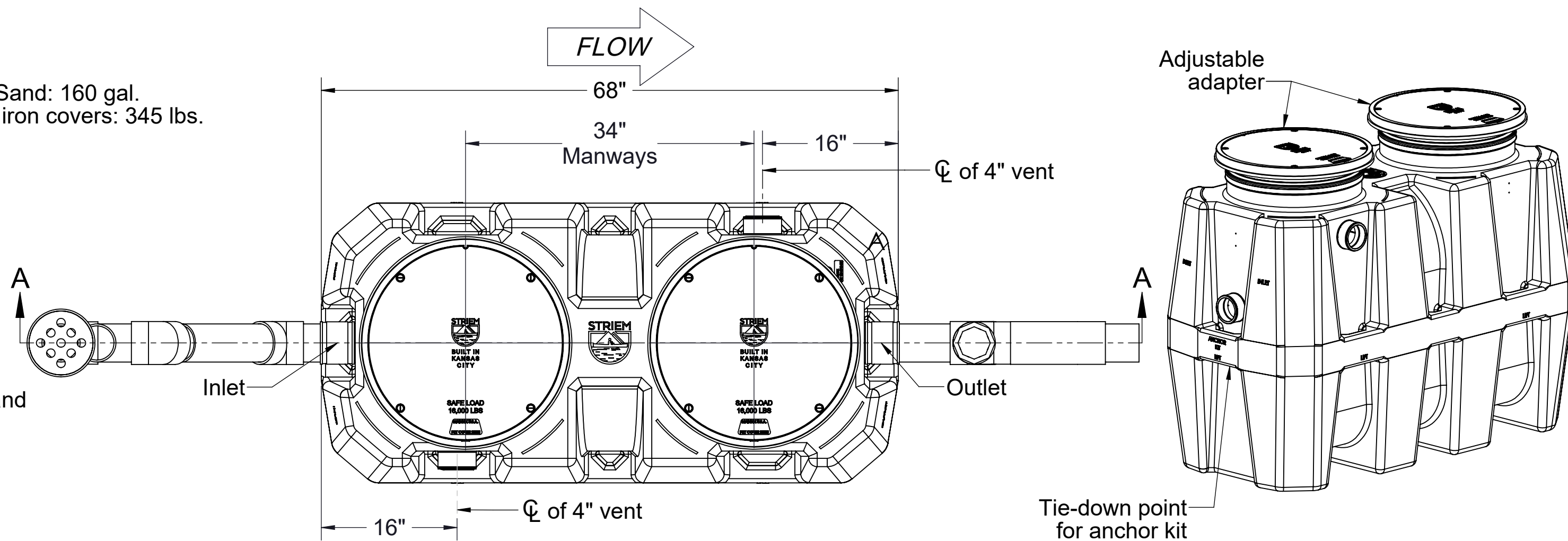

TOP VIEW

ISOMETRIC VIEW

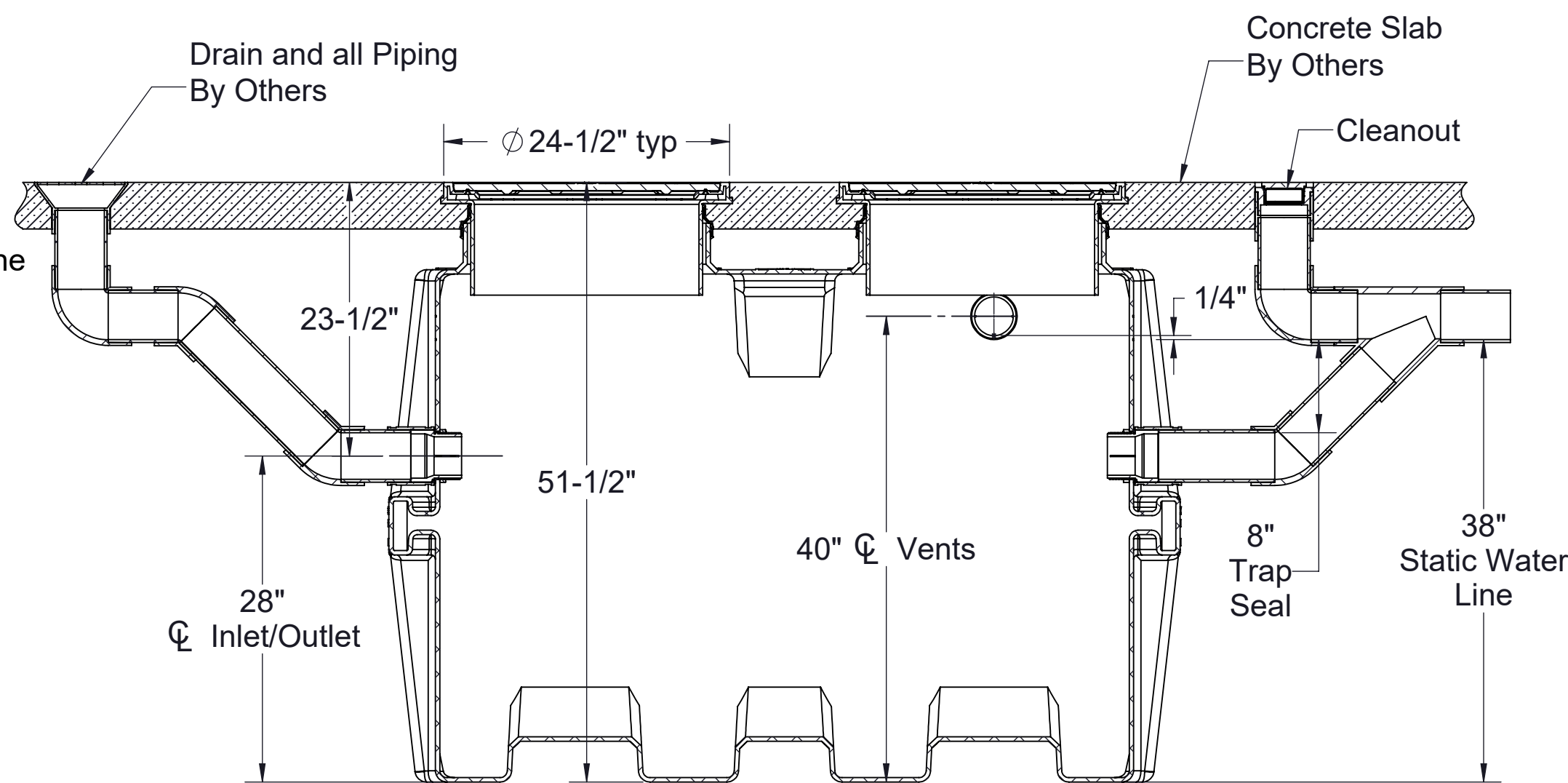

SECTION A-A

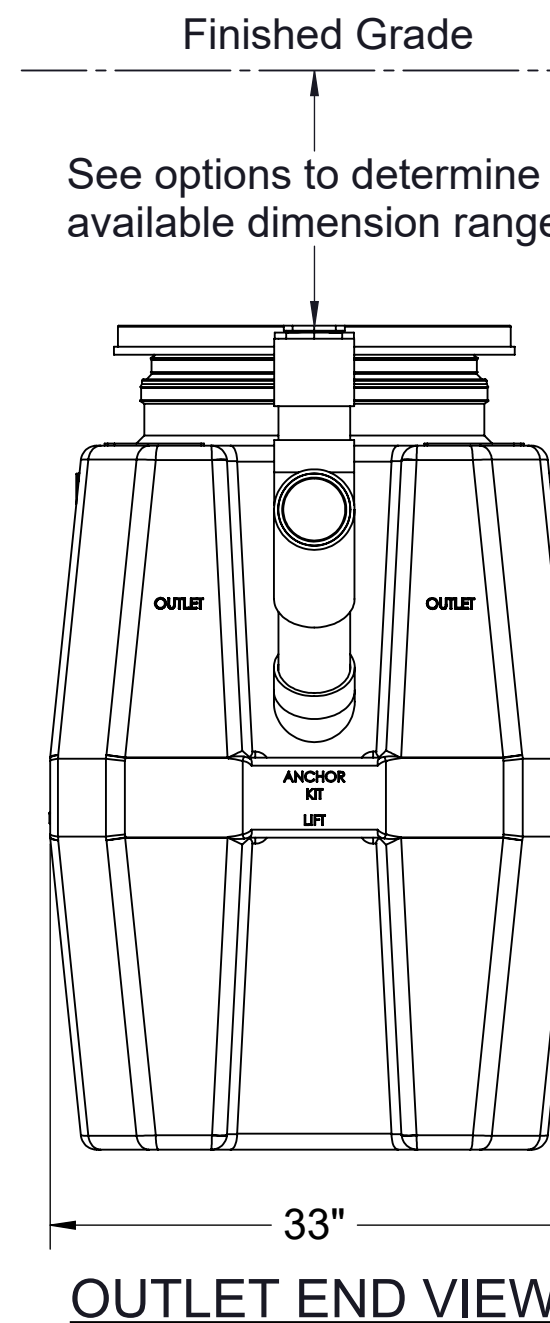

OUTLET END VIEW

MODEL NUMBER: OS-100-OMAHA			
DESCRIPTION: OMAHA TYPE 1 & TYPE 2 INTERCEPTOR			
DWG BY: JC	DATE: 8/11/2022	REV: 0	ECO:

SPECIFICATION SHEET

Striem
3100 Brinkerhoff
Kansas City, KS 66115
Tel: 913-222-1500
orders@striemco.com
www.striemco.com

Made in the U.S.A

PROPRIETARY AND CONFIDENTIAL

THE INFORMATION CONTAINED IN THIS DRAWING IS THE SOLE PROPERTY OF STRIEM, LLC. ANY REPRODUCTION IN PART OR AS A WHOLE WITHOUT THE WRITTEN PERMISSION OF STRIEM, LLC. IS PROHIBITED.