

SPECIFICATIONS

1. 4" Plain End inlet/outlet, 3" Plain End vents.
2. Max flow rate: 50 GPM.
3. Max flow rate to achieve 5 ppm of residual light liquid in effluent: 15 GPM.
4. Capacities: Liquid: 57 gal.; Oil: 40 gal.; Sand: 4 gal.
5. Unit weight with composite cover: 120 lbs.; with cast iron cover: 180 lbs.
6. Maximum operating temperature 140°F continuous.
7. Composite cover: 2,000 lb. capacity.

NOTES

1. Snap-in Flow control (ships with unit).
2. Seamless medium density polyethylene tank.
3. Unit supplied with built-in adapter for up to 2" of adjustability. Additional riser(s) available for deeper burial depth.
4. Cover placement allows full access to tank for proper maintenance.
5. Engineered inlet and outlet diffusers are removable to inspect/clean piping.
6. For on the-floor or buried applications.

DIFFUSION FLOW TECHNOLOGY

The inlet diffuser splits influent into three paths, creating laminar flow and utilizing the entire liquid volume of the tank for efficient oil separation. The calibrated openings greatly reduce influent turbulence. The influent enters the main chamber without disturbing the existing oil or sand layers. The bottom of the outlet diffuser allows only effluent that is free of oil to exit the tank.

ENGINEER SPECIFICATION GUIDE

Striem Oil Reserve™ oil/sand separator model OS-50-CS1 shall be lifetime guaranteed and made in USA of seamless, rotationally-molded polyethylene. Separator shall be furnished for above or below grade installation, with field adjustable riser system, snap-in flow control and (2) vent connections. Separator flow rate shall be 50 GPM. Separator oil capacity shall be 40 gallons. Sand capacity shall be 4 gallons. Cover shall provide water/gas-tight seal and have a maximum 2,000 lbs load capacity.

OPTIONS

- 2P - 2" Plain End SCH.40 Inlet / Outlet
- 2M - 2" Male Thread Inlet / Outlet
- 3P - 3" Plain End SCH.40 Inlet / Outlet
- 3M - 3" Male Thread Inlet / Outlet
- 4M - 4" Male Thread Inlet / Outlet
- CC24 - Integral Membrane Clamping Collar Kit
- C24-H - Highway Rated Bolted Composite Cover
- C24-HP - H20 Rated Pickable Cast Iron Cover
- HDK-2 - High Water Anchor Kit

TeleGlide RISER OPTIONS

- SR24 - >2"-21"
- LR24 - >21"-36"

Clean Sweep™ polypropylene coalescing media has been third party tested to performance standard CEN EN858-1 for class 1 coalescing separators.

Signature of Approval: _____
 Company: _____
 Date of Approval: _____
 Specifying Engineer: _____
 Engineering Firm: _____

PROPRIETARY AND CONFIDENTIAL

THE INFORMATION CONTAINED IN THIS DRAWING IS THE SOLE PROPERTY OF STRIEM, LLC. ANY REPRODUCTION IN PART OR AS A WHOLE WITHOUT THE WRITTEN PERMISSION OF STRIEM, LLC. IS PROHIBITED.

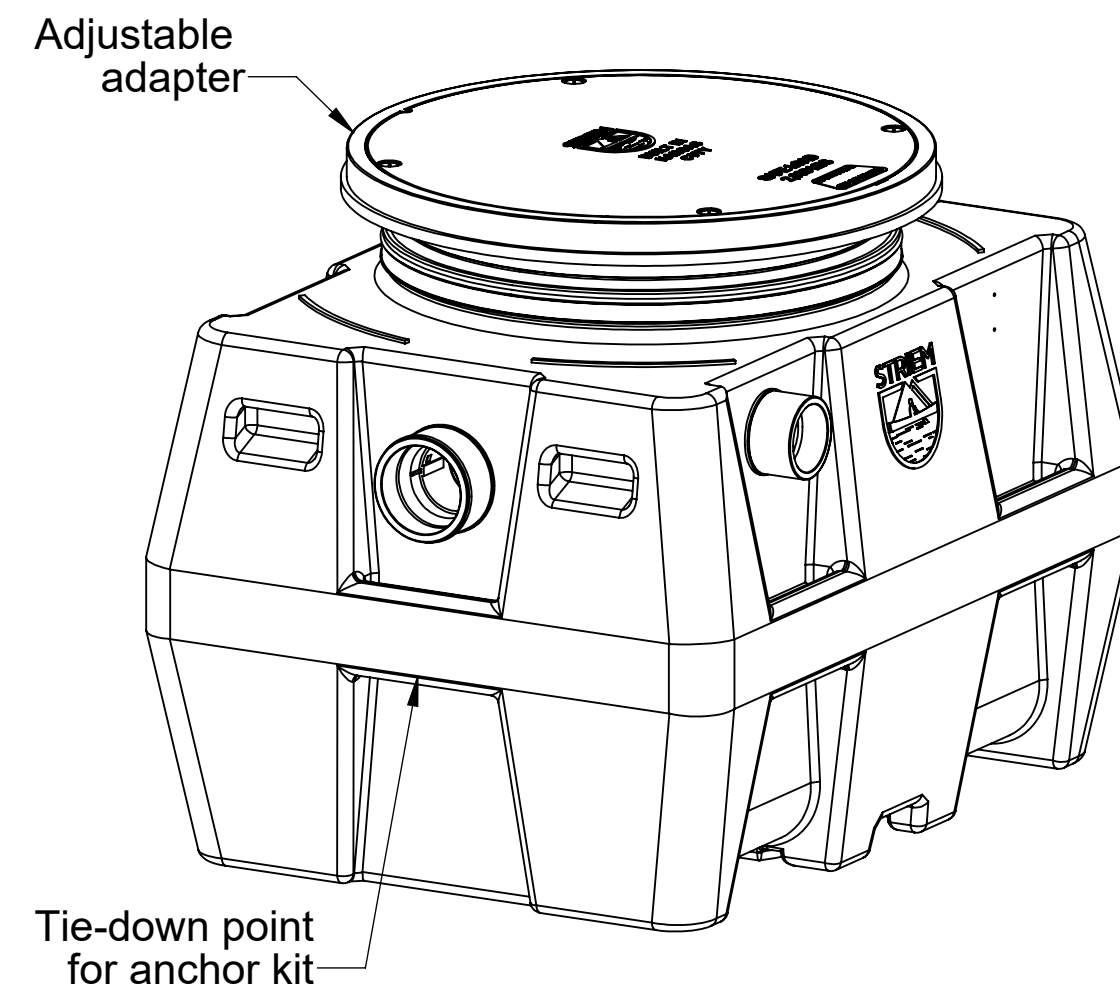
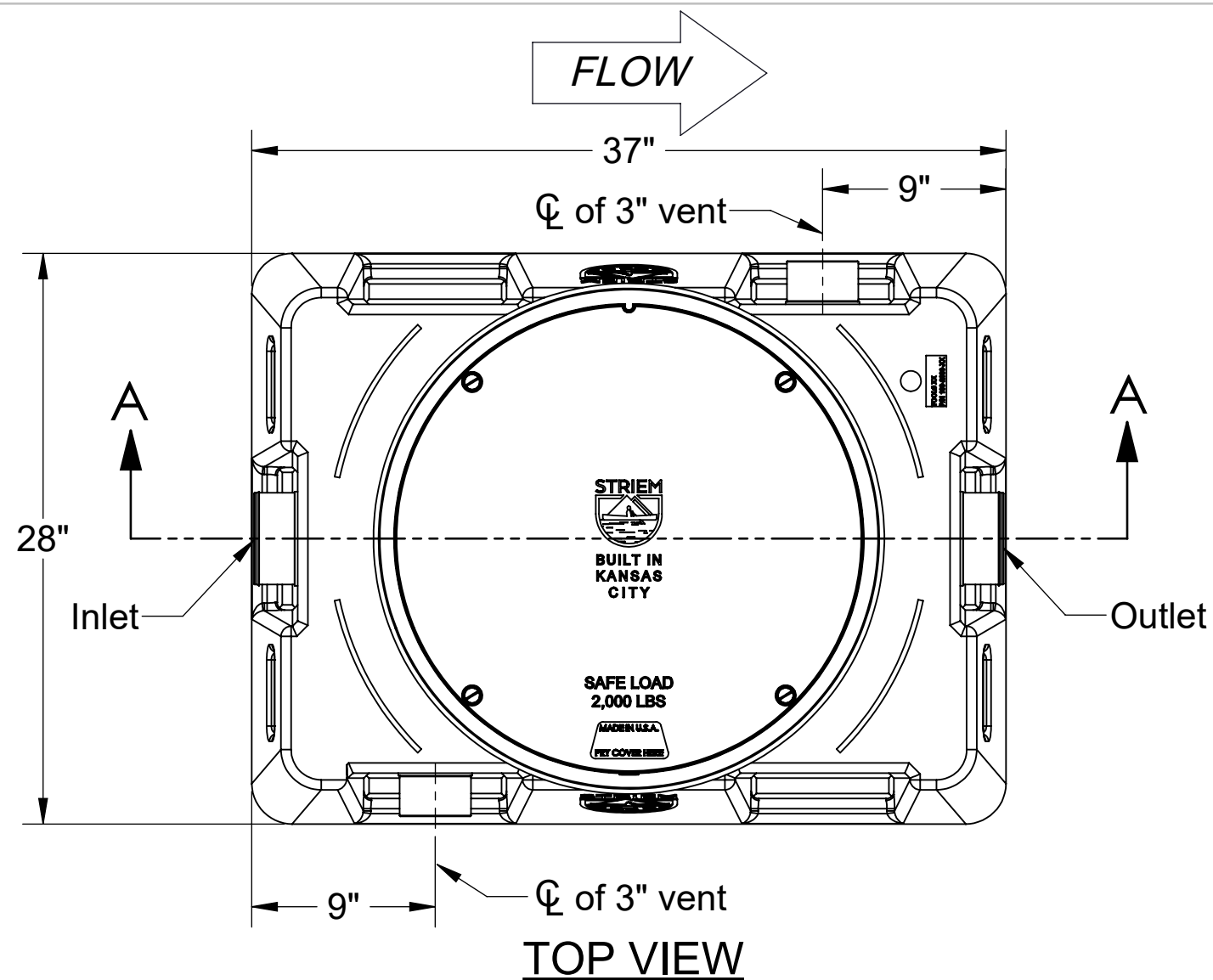

ISOMETRIC VIEW

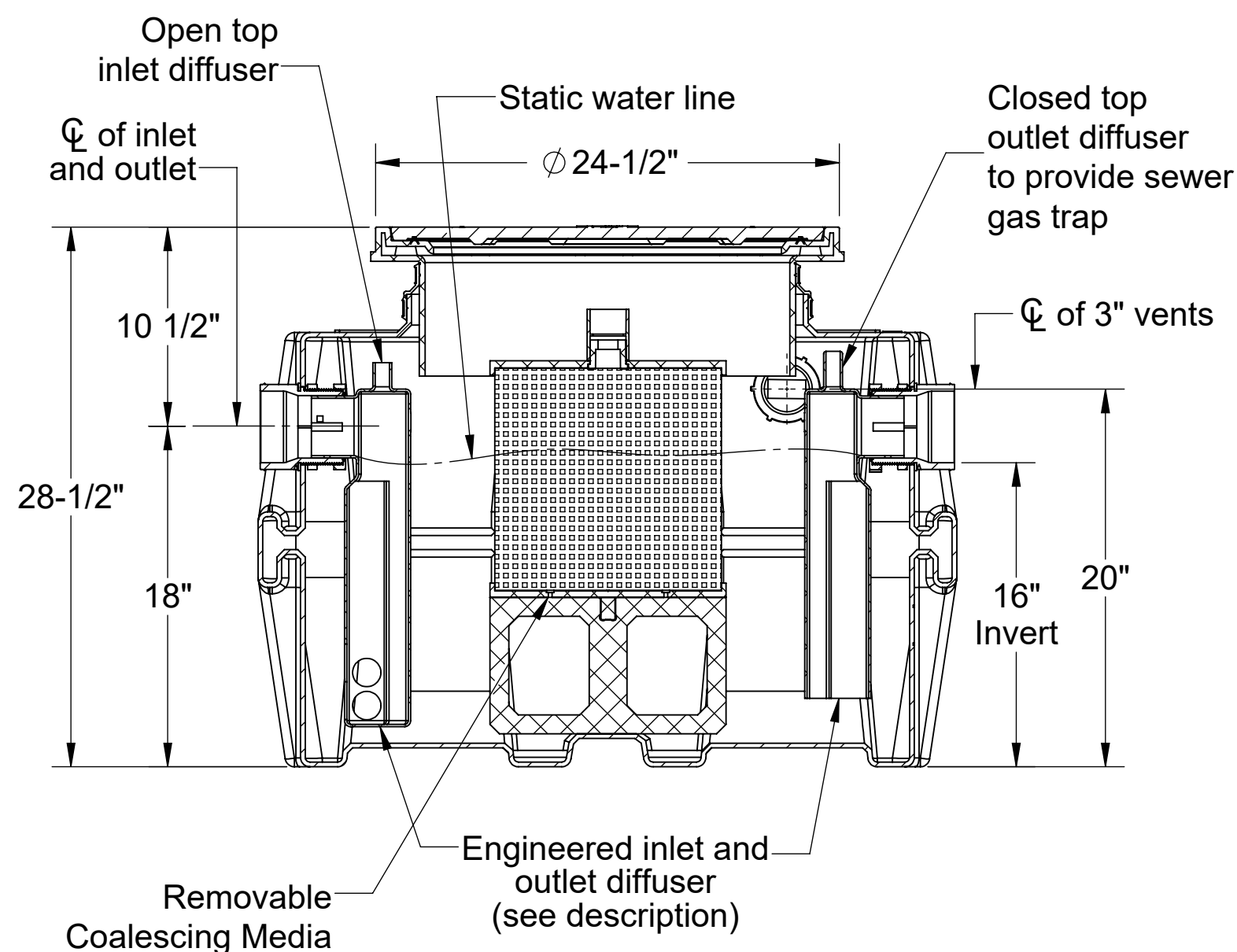

SECTION "A-A"

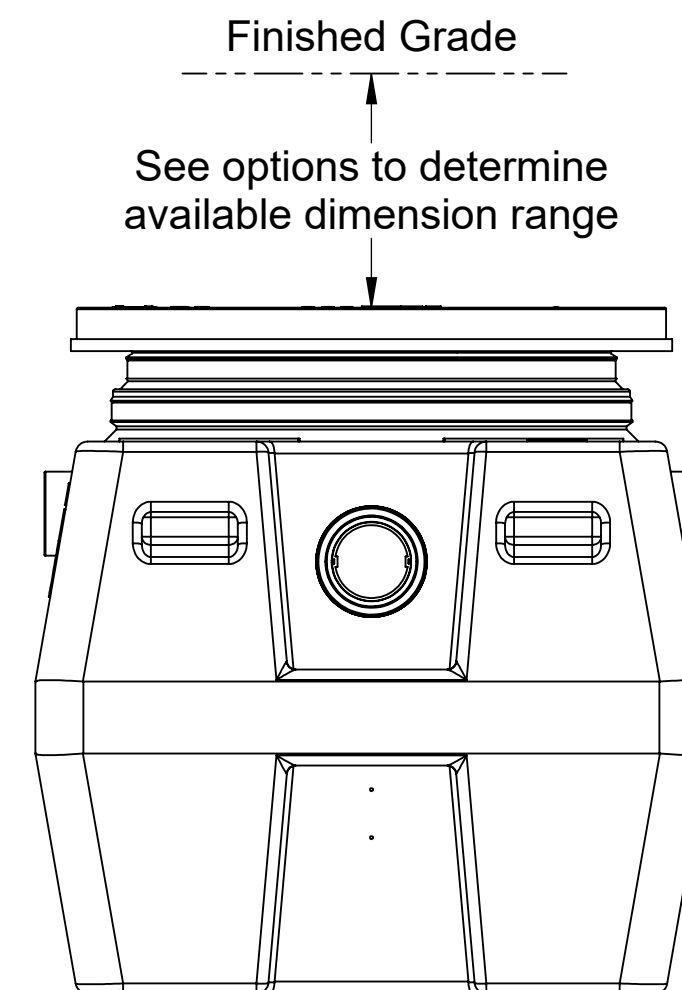

OUTLET END VIEW

MODEL NUMBER: OS-50-CS1	
DESCRIPTION: 50 GPM POLYETHYLENE OIL/SAND SEPARATOR WITH CLEAN SWEEP™ COALESCING MEDIA	
DWG BY: WLF	DATE: 7/23/21
REV:	ECO:

SPECIFICATION SHEET

Striem
 3100 Brinkerhoff
 Kansas City, KS 66115
 Tel: 913-222-1500
 orders@striemco.com
 www.striemco.com



Made in the U.S.A