

SPECIFICATIONS

1. 4" Plain End inlet/outlet, 3" Plain End vents, C24-M cover standard.
2. Max flow rate: 50 GPM.
3. Max flow rate to achieve 5 ppm of residual light liquid in effluent: 15 GPM.
4. Liquid capacity: 57 Gallons.
5. Oil capacity: 40 Gallons.
6. Solids capacity: 4 Gallons.
7. Unit weight w/ standard cover: 120 lbs.; w/ cast iron cover: 180 lbs.
8. Maximum operating temperature 140°F continuous.

NOTES

1. For gravity drainage applications only.
2. Do not use for pressure applications.
3. Cover placement allows full access to tank for proper maintenance.
4. Handle of removable coalescing media may be extended using 1-1/2" PVC pipe by others.

DIFFUSION FLOW TECHNOLOGY

The inlet diffuser splits influent into three paths, creating laminar flow and utilizing the entire liquid volume of the tank for efficient oil separation. The calibrated openings greatly reduce influent turbulence. The influent enters the main chamber without disturbing the existing oil or sand layers. The bottom of the outlet diptube allows only effluent that is free of oil to exit the tank.

ENGINEER SPECIFICATION GUIDE

Striem oil separator model OS-50-CS1 shall be lifetime guaranteed and made in the USA. Separator shall be constructed of polyethylene. Separator shall be manufactured for above- or below-grade installation. Field-adjustable riser system is available as an option to bring manhole cover to grade. Separator flow rate shall be 50 GPM. Separator liquid holding capacity shall be 57 gallons and oil capacity shall be 40 gallons. Solids capacity shall be 4 gallons. Cover shall provide water/gas-tight seal and have a maximum 2,000 lbs. load capacity.

THIRD PARTY STRUCTURAL ANALYSIS

The OS-50-CS1 has been structurally analyzed in accordance with the requirements of IBC 2012 and ASCE/SEI 7 for direct burial. The maximum burial depth and backfill material are specified in our installation instructions. The structural design has been reviewed and sealed by a professional engineer registered in the state of California. A sealed structural analysis report is available upon request.

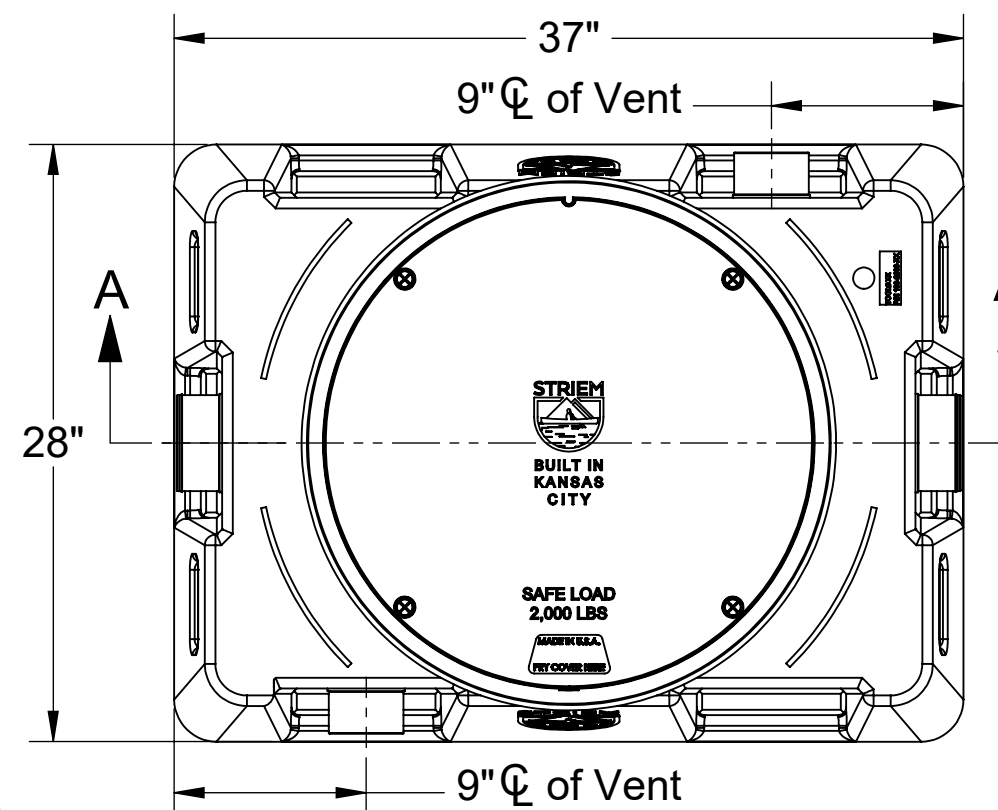

TOP VIEW

OPTIONS	
Connection Options	
Inlet / Outlet	Size
<input type="checkbox"/> Plain End	<input type="checkbox"/> 2"
<input type="checkbox"/> Male Thread	<input type="checkbox"/> 3"
	<input type="checkbox"/> 4"
Riser Options	
From Factory: Up to 5"	
<input type="checkbox"/> Up to 24": SR24	
<input type="checkbox"/> Up to 39": LR24	
Additional Options	
<input type="checkbox"/> HDK-2: High Water Table Hold Down Kit	
<input type="checkbox"/> CC24: Integral Membrane Clamping Collar Kit	
<input type="checkbox"/> C24-H: Highway Rated Bolted Composite Cover	
<input type="checkbox"/> C24-HP: H2O Rated Pickable Cast Iron Cover	

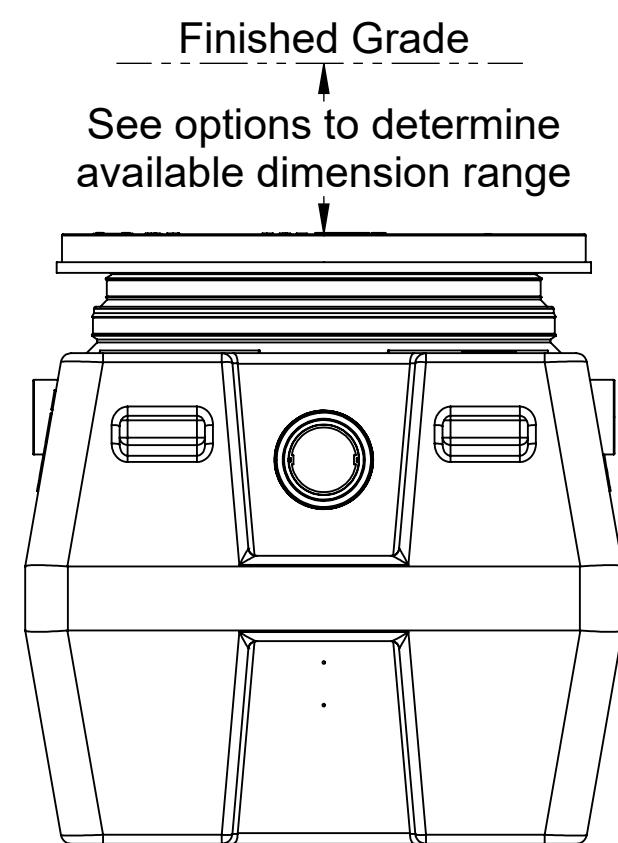

END VIEW

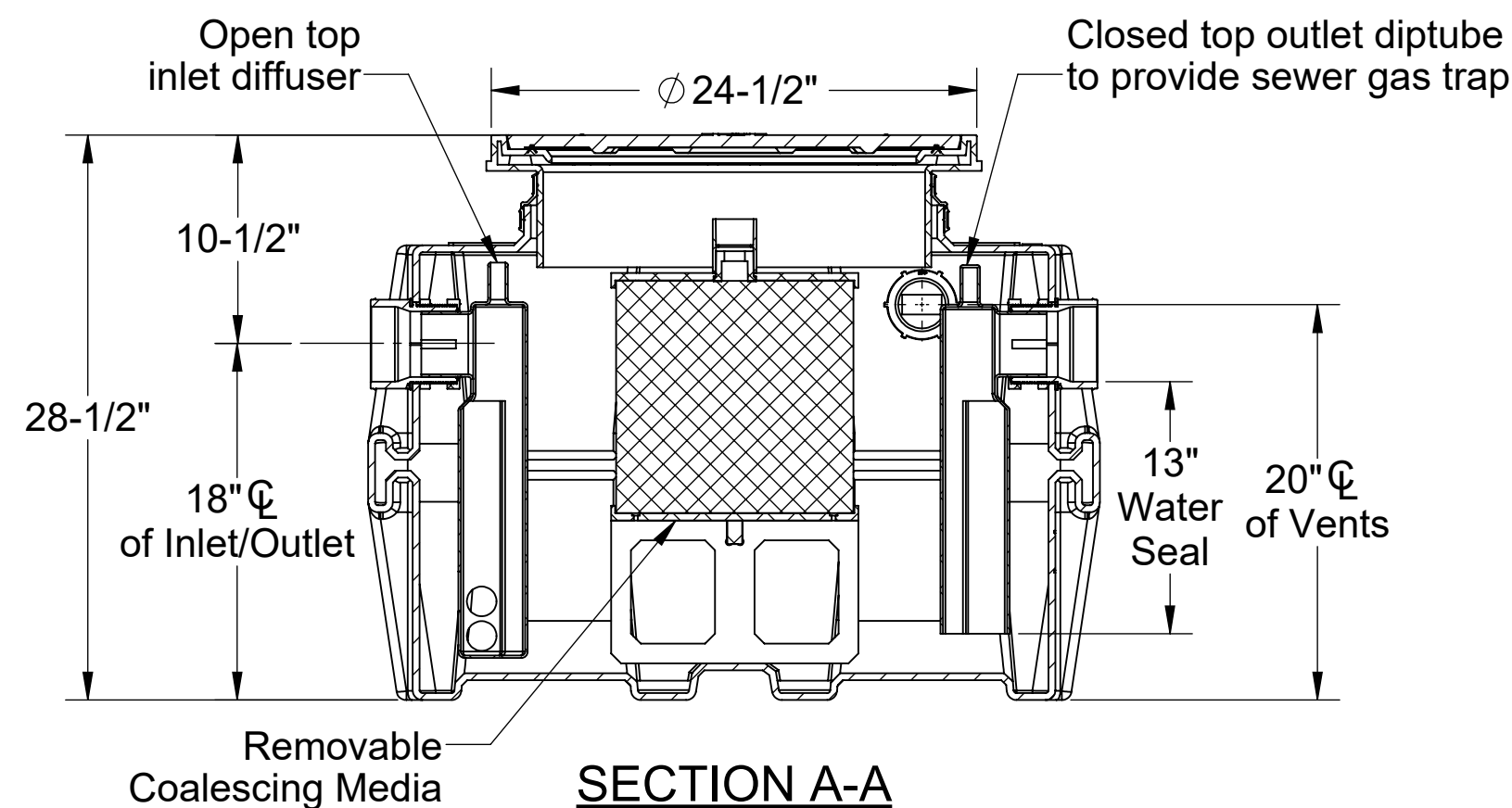

SECTION A-A

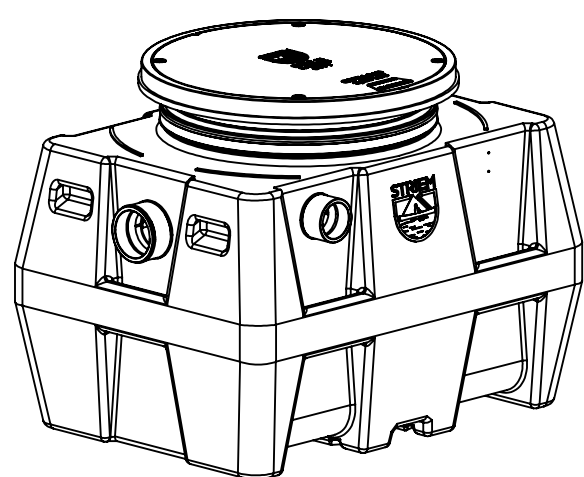

PROPRIETARY AND CONFIDENTIAL
 THE INFORMATION CONTAINED IN THIS DRAWING IS THE SOLE PROPERTY OF STRIEM, LLC.
 ANY REPRODUCTION IN PART OR AS A WHOLE WITHOUT THE WRITTEN PERMISSION OF STRIEM, LLC. IS PROHIBITED.

MODEL NUMBER:	OS-50-CS1
DESCRIPTION:	50 GPM POLYETHYLENE OIL/SAND SEPARATOR WITH CLEAN SWEEP™ COALESCING MEDIA
DWG BY: ENG	DATE: 6/30/2023
REV: 2	

SPECIFICATION SHEET

Striem
 Kansas City, KS
 Tel: 913-222-1500
 orders@striemco.com
 www.striemco.com

Made in the U.S.A

