

SPECIFICATIONS

1. 4" Plain End inlet/outlet, 3" Plain End vents, C24-M cover standard.
2. Max flow rate: 50 GPM.
3. Liquid capacity: 57 Gallons (7.6 cu. ft.).
4. Oil capacity: 40 Gallons.
5. Solids capacity: 7 Gallons.
6. Unit weight w/ standard cover: 93 lbs.; w/ cast iron cover: 153 lbs.
7. Maximum operating temperature 140°F continuous.

NOTES

1. For gravity drainage applications only.
2. Do not use for pressure applications.
3. Cover placement allows full access to tank for proper maintenance.

DIFFUSION FLOW TECHNOLOGY

The inlet diffuser splits influent into three paths, creating laminar flow and utilizing the entire liquid volume of the tank for efficient oil separation. The calibrated openings greatly reduce influent turbulence. The influent enters the main chamber without disturbing the existing oil or sand layers. The bottom of the outlet diptube allows only effluent that is free of oil to exit the tank.

ENGINEER SPECIFICATION GUIDE

Striem oil separator model OS-50 shall be lifetime guaranteed and made in the USA. Separator shall be constructed of polyethylene. Separator shall be manufactured for above- or below-grade installation. Field-adjustable riser system is available as an option to bring manhole cover to grade. Separator flow rate shall be 50 GPM. Separator liquid holding capacity shall be 57 gallons and oil capacity shall be 40 gallons. Solids capacity shall be 7 gallons. Cover shall provide water/gas-tight seal and have a maximum 2,000 lbs. load capacity.

THIRD PARTY STRUCTURAL ANALYSIS

The OS-50 has been structurally analyzed in accordance with the requirements of IBC 2012 and ASCE/SEI 7 for direct burial. The maximum burial depth and backfill material are specified in our installation instructions. The structural design has been reviewed and sealed by a professional engineer registered in the state of California. A sealed structural analysis report is available upon request.

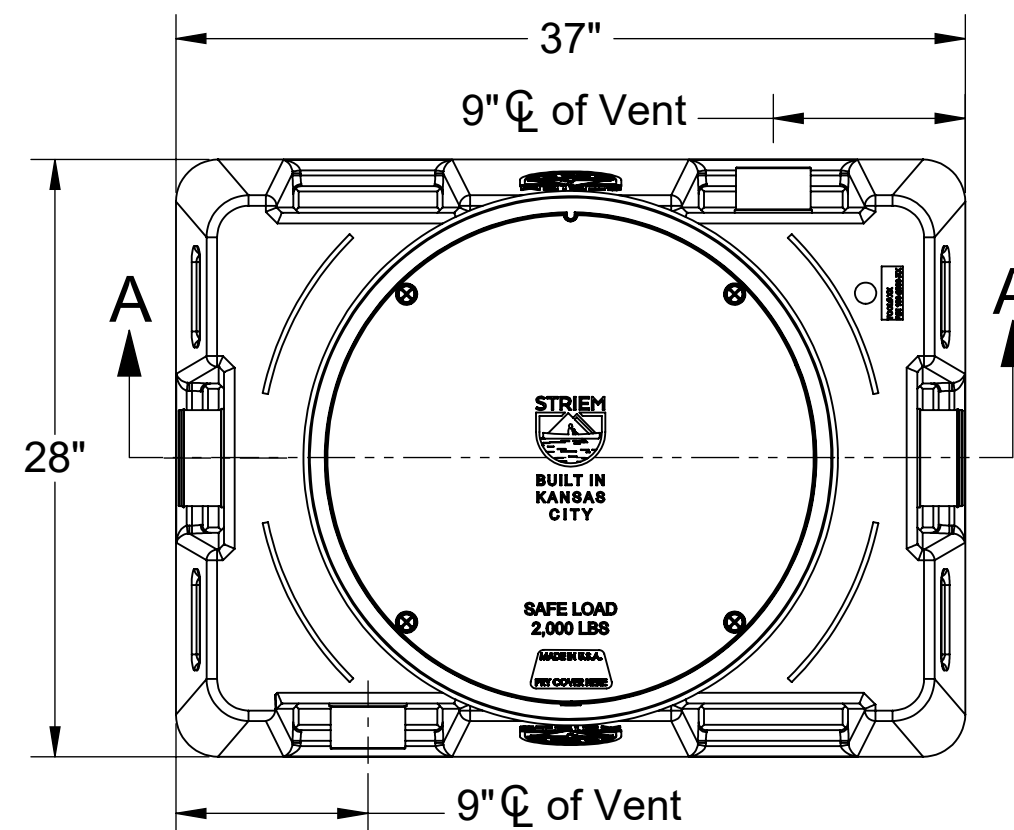

TOP VIEW

OPTIONS

Connection Options

Inlet / Outlet	Size
<input type="checkbox"/> Plain End	<input type="checkbox"/> 2"
<input type="checkbox"/> Male Thread	<input type="checkbox"/> 3"
	<input type="checkbox"/> 4"

Riser Options

- From Factory:** Up to 5"
- Up to 24": **SR24**
 - Up to 39": **LR24**

Additional Options

- HDK-2:** High Water Table Hold Down Kit
- CC24:** Integral Membrane Clamping Collar Kit
- C24-H:** Highway Rated Bolted Composite Cover
- C24-HP:** H20 Rated Pickable Cast Iron Cover
- CS1:** Clean Sweep™ Coalescing Media*
- SS:** Slick Stick™ Oil Level Monitoring System**

*Clean Sweep Coalescing Media not compatible with SS
 **Monitoring system will raise covers by 3".

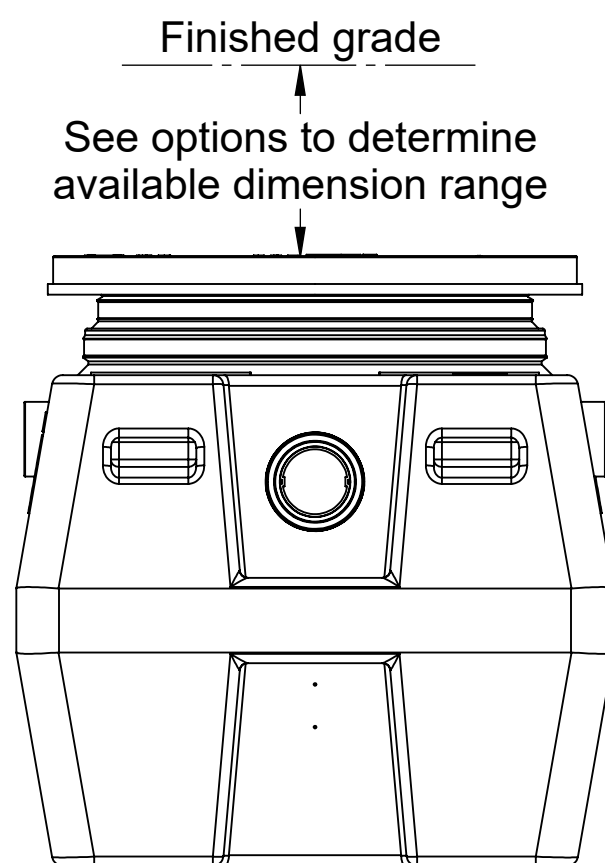

END VIEW

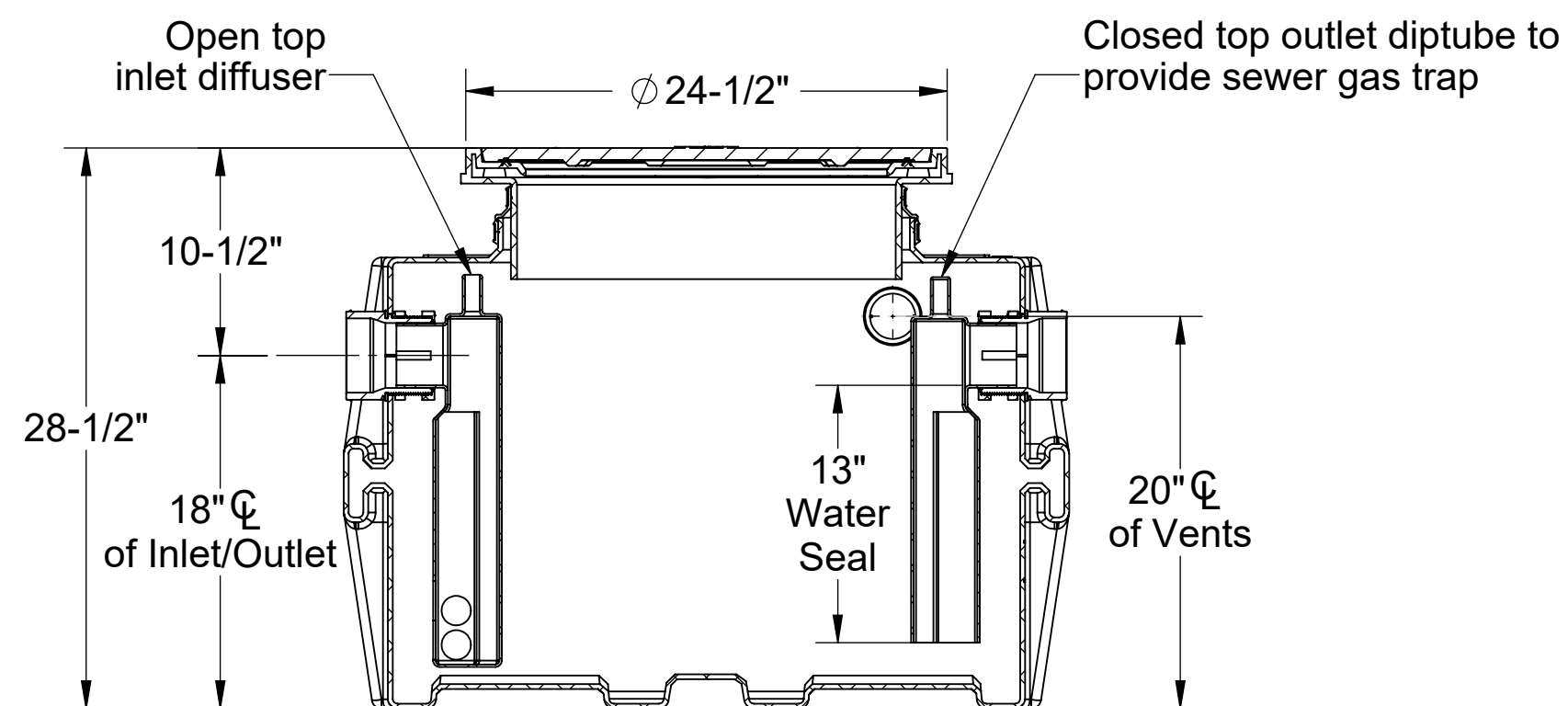

SECTION A-A

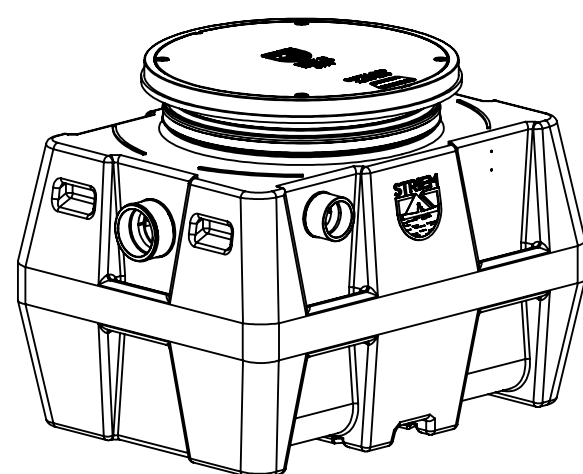

PROPRIETARY AND CONFIDENTIAL
 THE INFORMATION CONTAINED IN THIS DRAWING IS THE SOLE PROPERTY OF STRIEM, LLC.
 ANY REPRODUCTION IN PART OR AS A WHOLE WITHOUT THE WRITTEN PERMISSION OF STRIEM, LLC. IS PROHIBITED.

MODEL NUMBER:	OS-50
DESCRIPTION:	50 GPM POLYETHYLENE OIL/SAND SEPARATOR
DWG BY: ENG	DATE: 6/30/2023
REV: 2	

SPECIFICATION SHEET

Striem
 Kansas City, KS
 Tel: 913-222-1500
 orders@striemco.com
 www.striemco.com

Made in the U.S.A

