

**SPECIFICATIONS**

1. 3" Plain end vents standard.
2. Max flow rate: 314 GPM
3. Max flow rate to achieve 5 ppm of residual light liquid in effluent: 45 GPM
4. Liquid capacity: 560 Gallons (74.6 cu. ft.)
5. Oil capacity: 285 Gallons
6. Solids/sediment capacity: 81 Gallons
7. Unit weight: 1125 lbs.
8. H2O rated cast iron covers.
9. Maximum operating temperature 140°F continuous.
10. For buried applications only.

**ENGINEER SPECIFICATION GUIDE**

Striem Oil Tanker™ model OT-500-CS3 shall be lifetime guaranteed and made in USA of High Density Polyethylene. Separator shall be furnished for below grade installation with field adjustable riser system. Separator flow rate shall be 314 GPM. Separator oil capacity shall be 285 gallons. Sand capacity shall be 81 gallons. Separator shall be certified to IAPMO IGC 183-2016.

Clean Sweep™ polypropylene coalescing media has been third party tested to performance standard CEN EN858-1 for class 1 coalescing separators.

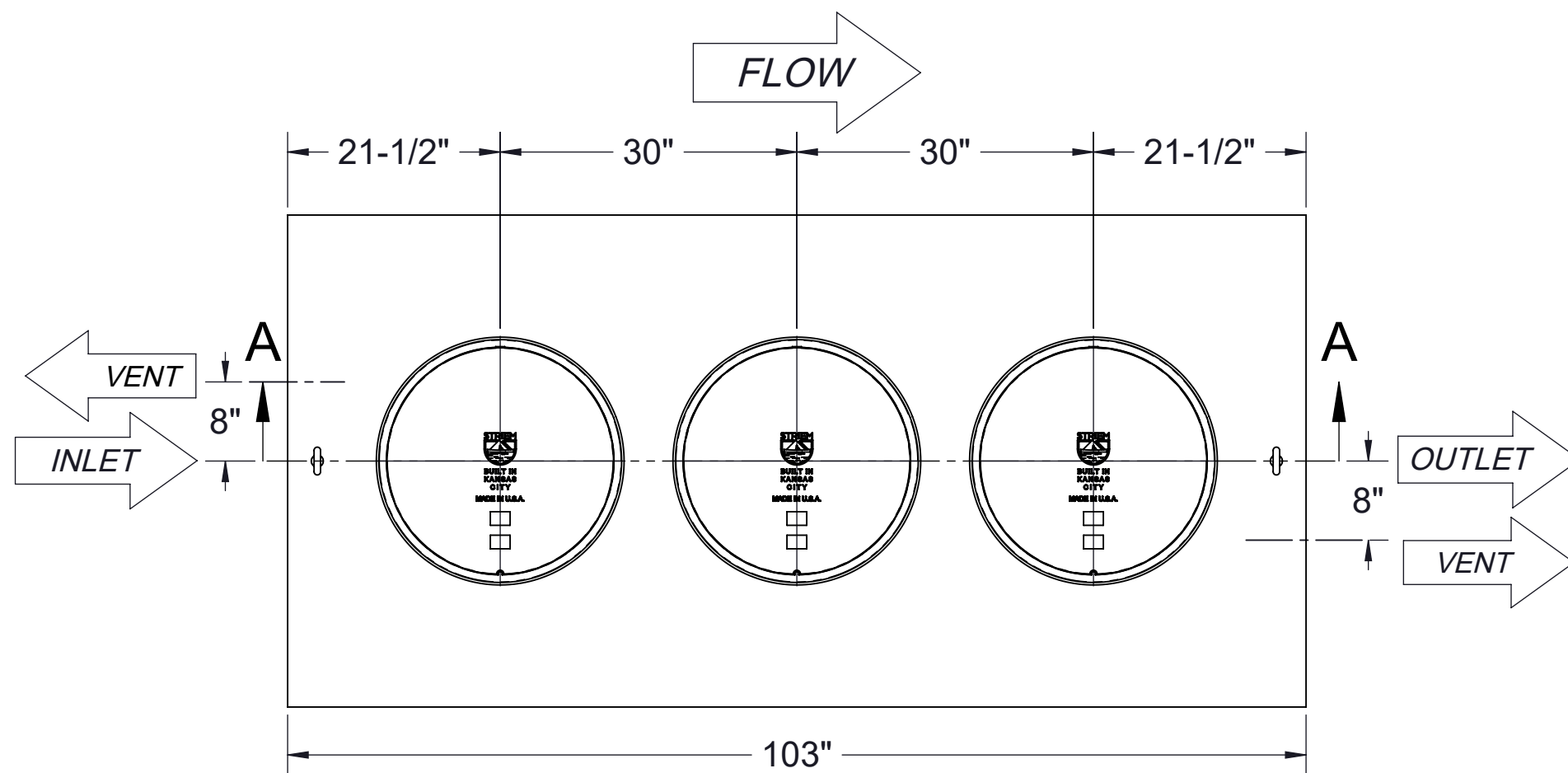

**TOP VIEW**

**Directions:** Choose connections, select options, sign and submit with purchase order.

**Connections**

- |                                      |  |
|--------------------------------------|--|
| <b>Inlet / Outlet</b>                | <input type="checkbox"/> 4"                  |
| <input type="checkbox"/> Plain End   | <input type="checkbox"/> 6"                  |
| <input type="checkbox"/> Male Thread | <input type="checkbox"/> 8" (Plain End Only) |

**Riser Options**

- Included :** 0" - 5"
- SR24 (3) : >5" - 24"
  - LR24 (3) : >24" - 39"
  - SR24 (6) : >39" - 43"
  - SR24 (3) + LR24 (3) : >43" - 58"
  - LR24 (6) : >58" - 72"
  - SR24 (3) + LR24 (6) : >72" - 90"
  - LR24 (9) : >90" - 106"

**Additional Options**

- HDK-500 : High Water Table Hold Down Kit
  - SS : Slick Stick™ Oil Level Monitoring System\*
- \*Monitoring system will raise covers by 3".

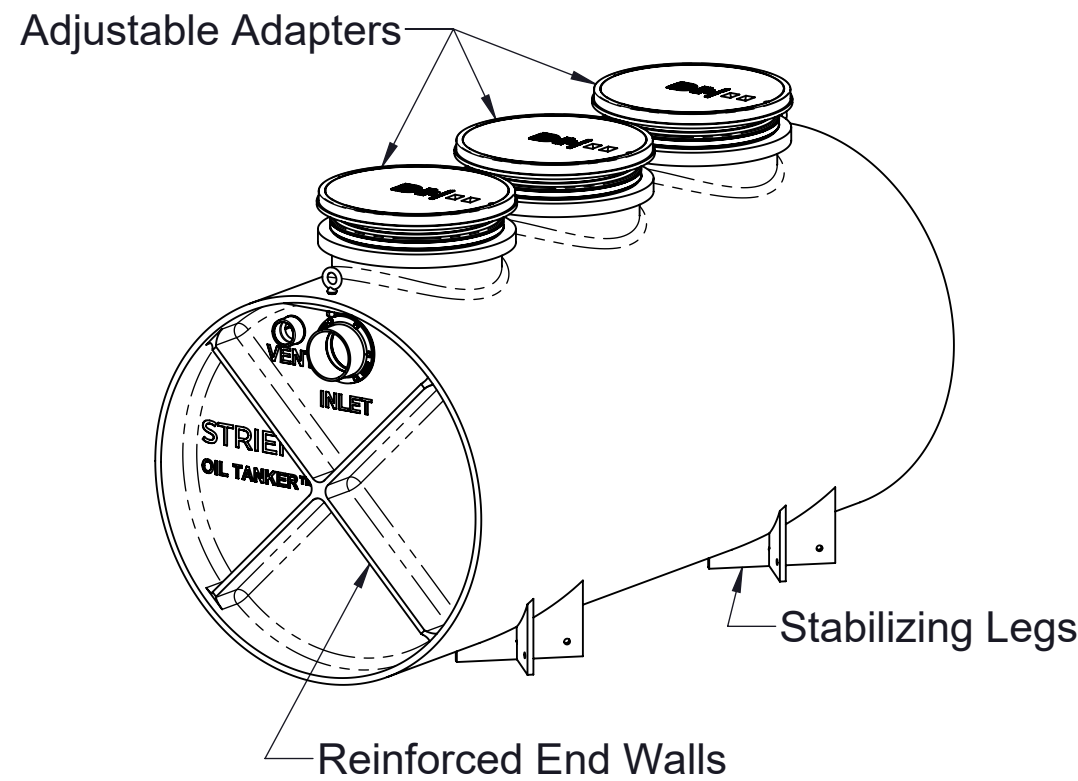

**ISOMETRIC VIEW**

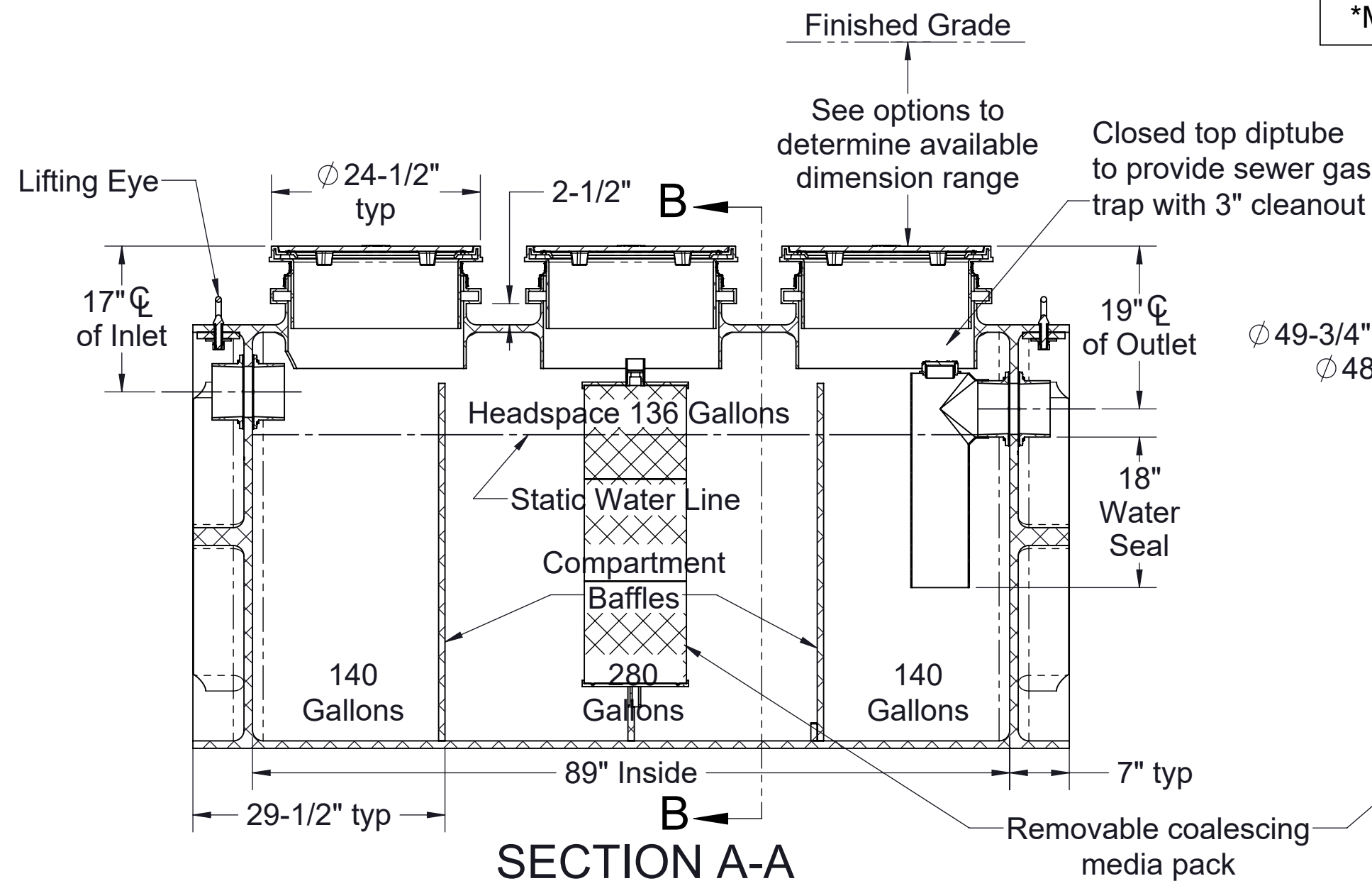

**SECTION A-A**

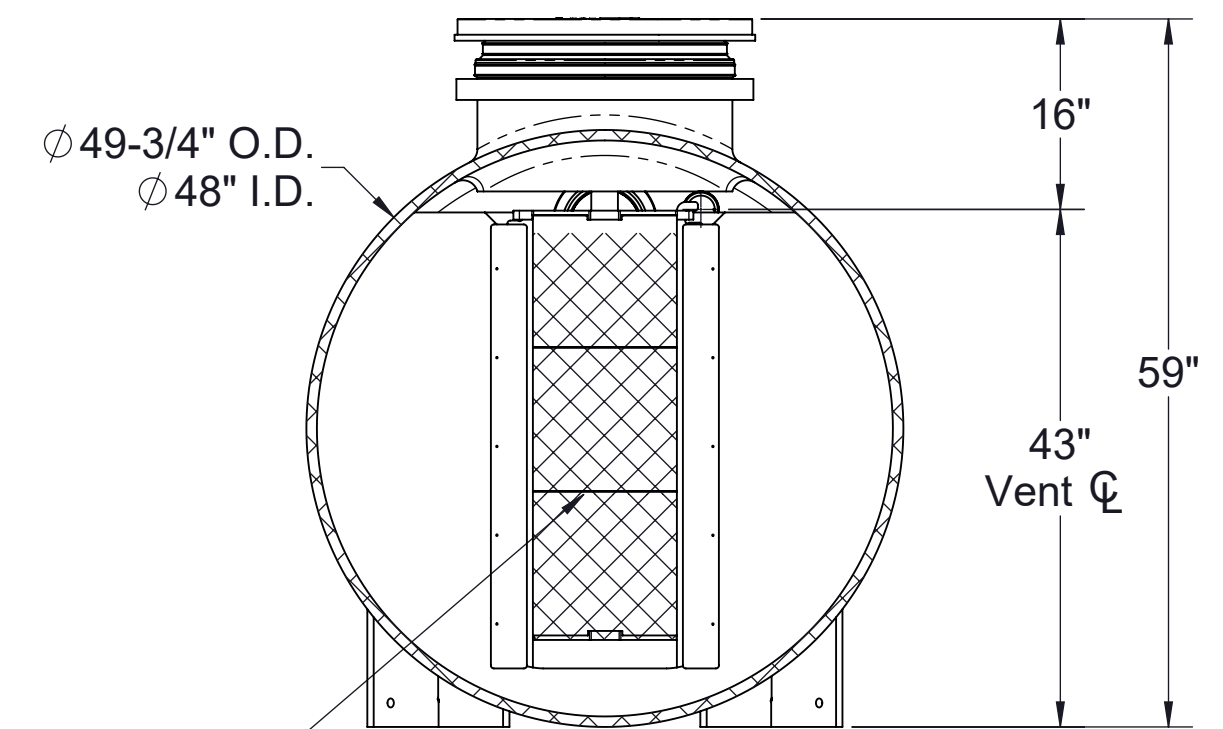

**SECTION B-B**

Signature of Approval: \_\_\_\_\_  
 Company: \_\_\_\_\_  
 Date of Approval: \_\_\_\_\_  
 Specifying Engineer: \_\_\_\_\_  
 Engineering Firm: \_\_\_\_\_

PO IS NON-CANCELABLE  
 ORDER IS NON-RETURNABLE

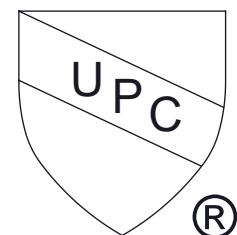

<b>MODEL NUMBER:</b> OT-500-CS3			
<b>DESCRIPTION:</b> OIL TANKER™ POLYETHYLENE OIL SEPARATOR WITH CLEAN SWEEP™ COALESCING MEDIA 560 GALLON CAPACITY			
<b>DWG BY:</b> MJ	<b>DATE:</b> 01/28/2022	<b>REV:</b> 0	<b>ECO:</b>

**SPECIFICATION SHEET**

**Striem**  
 3100 Brinkerhoff  
 Kansas City, KS 66115  
 Tel: 913-222-1500  
 orders@striemco.com  
 www.striemco.com



Made in the U.S.A

PROPRIETARY AND CONFIDENTIAL

THE INFORMATION CONTAINED IN THIS DRAWING IS THE SOLE PROPERTY OF STRIEM, LLC. ANY REPRODUCTION IN PART OR AS A WHOLE WITHOUT THE WRITTEN PERMISSION OF STRIEM, LLC. IS PROHIBITED.