

**SPECIFICATIONS**

1. 3" Plain end vents standard.
2. Max flow rate: 314 GPM
3. Max flow rate to achieve 5 ppm of residual light liquid in effluent: 45 GPM
4. Liquid capacity: 750 Gallons (100.3 cu. ft.)
5. Oil capacity: 323 Gallons
6. Solids/sediment capacity: 148 Gallons
7. Unit weight: 1353 lbs.
8. H2O rated cast iron covers.
9. Maximum operating temperature 140°F continuous.
10. For buried applications only.

**ENGINEER SPECIFICATION GUIDE**

Striem Oil Tanker™ model OT-750-CS3 shall be lifetime guaranteed and made in USA of High Density Polyethylene. Separator shall be furnished for below grade installation with field adjustable riser system. Separator flow rate shall be 314 GPM. Separator oil capacity shall be 323 gallons. Sand capacity shall be 148 gallons. Separator shall be certified to IAPMO IGC 183-2016.

Clean Sweep™ polypropylene coalescing media has been third party tested to performance standard CEN EN858-1 for class 1 coalescing separators.

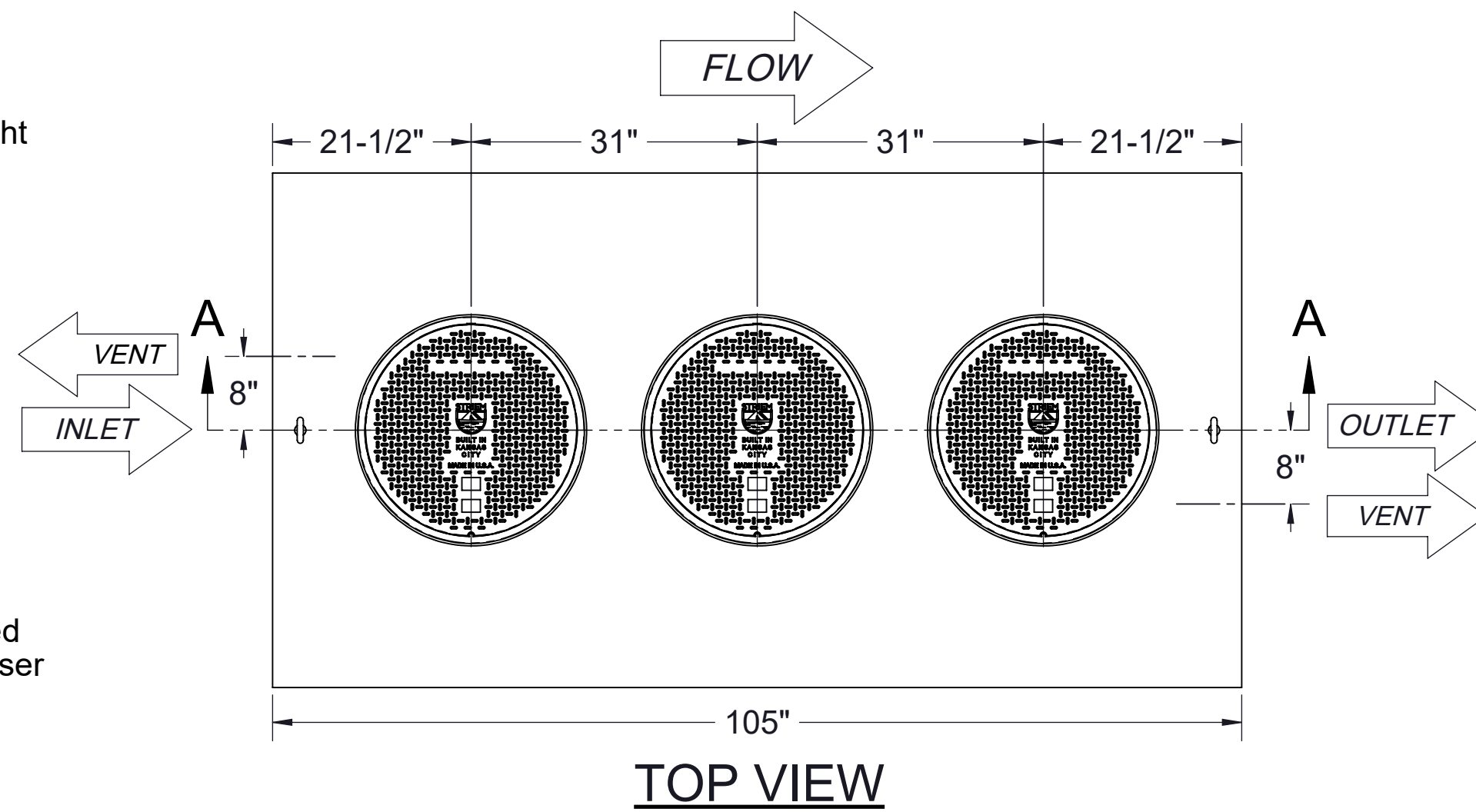

**Directions:** Choose connections, select options, sign and submit with purchase order.

Connections		Size
<input type="checkbox"/> Inlet / Outlet	<input type="checkbox"/> Plain End	<input type="checkbox"/> 4"
<input type="checkbox"/> Male Thread	<input type="checkbox"/> 6"	<input type="checkbox"/> 8" (Plain End Only)

Riser Options	
<input type="checkbox"/> Included : 0" - 5"	<input type="checkbox"/> SR24 (3) : >5" - 24"
<input type="checkbox"/> LR24 (3) : >24" - 39"	<input type="checkbox"/> SR24 (6) : >39" - 43"
<input type="checkbox"/> SR24 (3) + LR24 (3) : >43" - 58"	<input type="checkbox"/> LR24 (6) : >58" - 72"
<input type="checkbox"/> SR24 (6) + LR24 (3) : >72" - 90"	<input type="checkbox"/> LR24 (9) : >90" - 106"

Additional Options	
<input type="checkbox"/> HDK-750 : High Water Table Hold Down Kit	<input type="checkbox"/> SS : Slick Stick™ Oil Level Monitoring System*
*Monitoring system will raise covers by 3".	

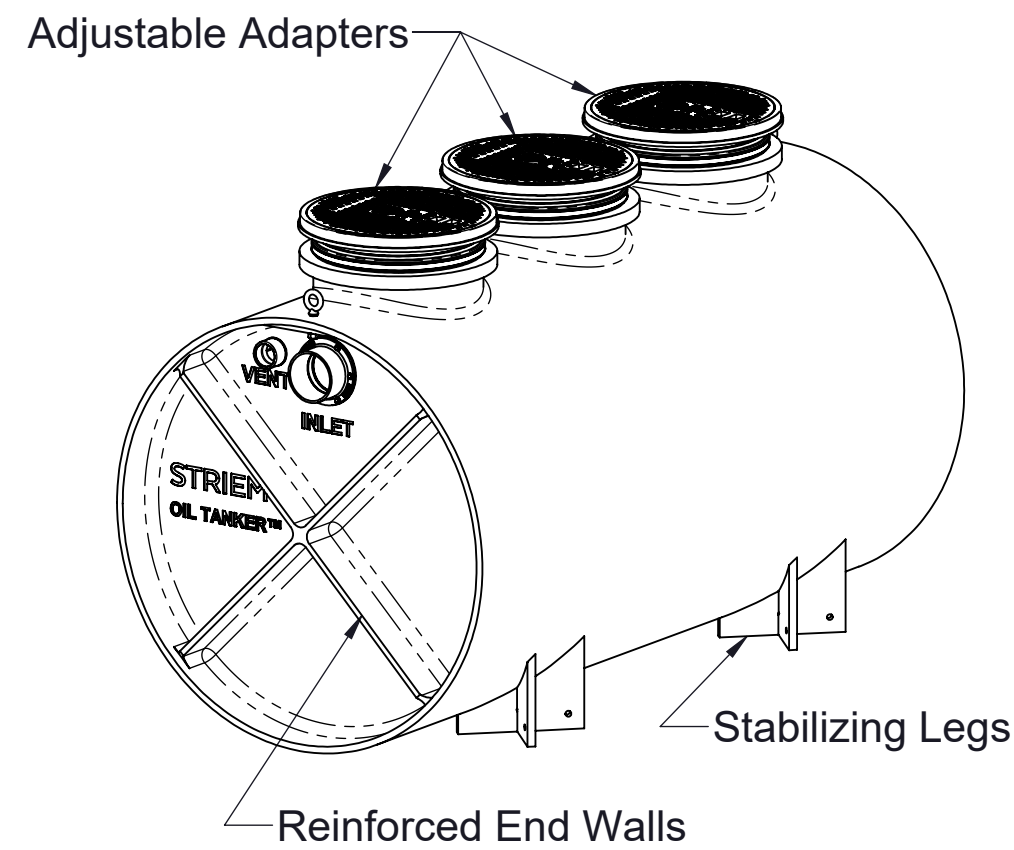

**ISOMETRIC VIEW**

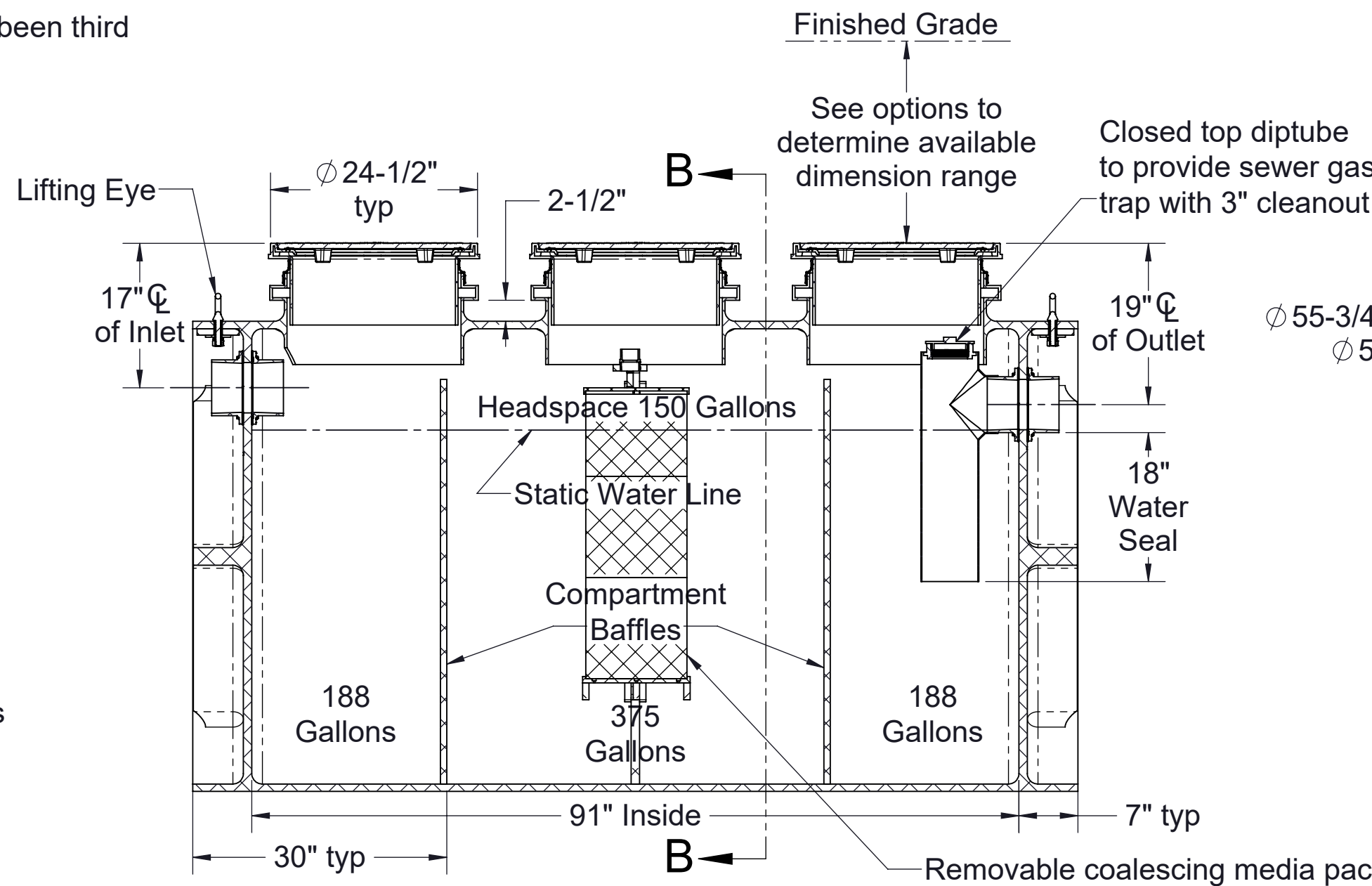

**SECTION A-A**

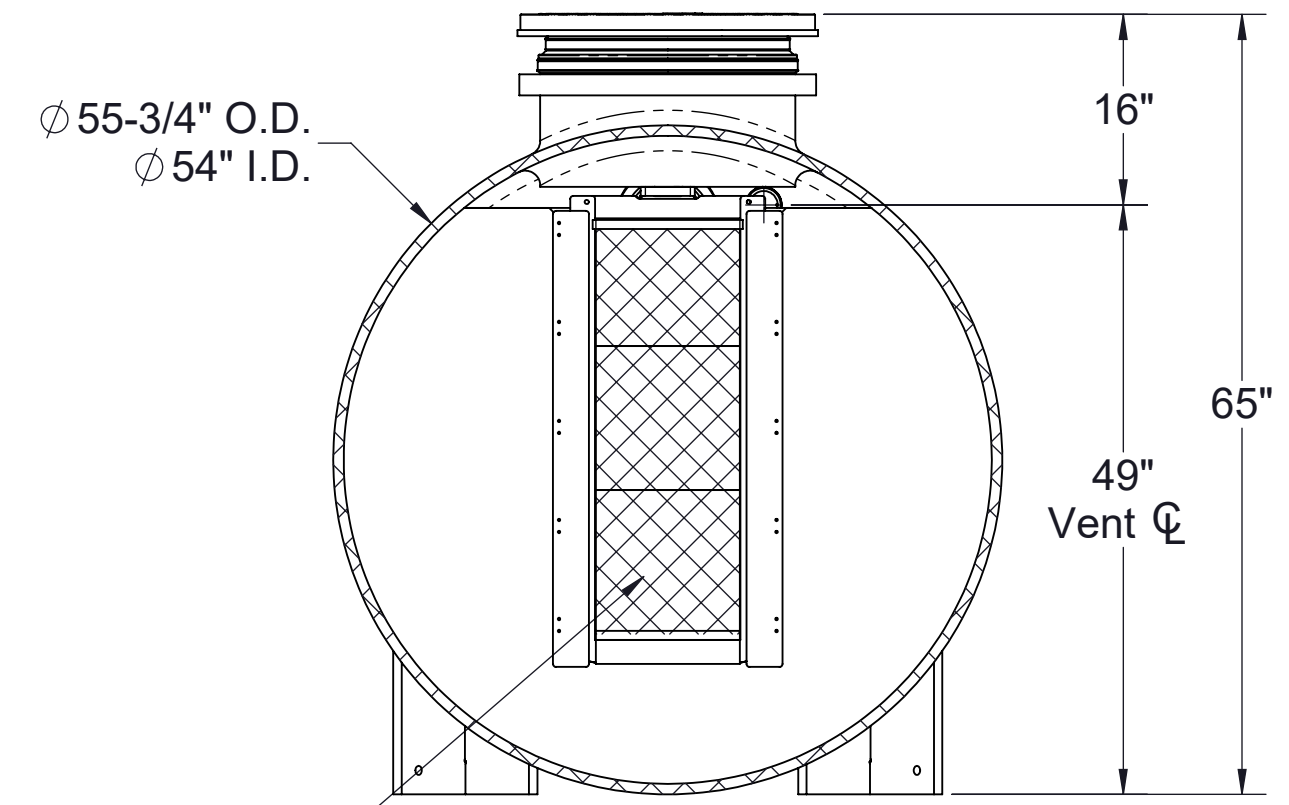

**SECTION B-B**

Signature of Approval: \_\_\_\_\_  
 Company: \_\_\_\_\_  
 Date of Approval: \_\_\_\_\_  
 Specifying Engineer: \_\_\_\_\_  
 Engineering Firm: \_\_\_\_\_

PO IS NON-CANCELABLE  
 ORDER IS NON-RETURNABLE

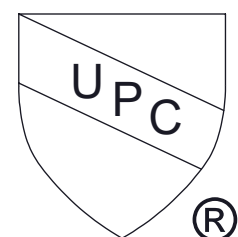

<b>MODEL NUMBER:</b>	OT-750-CS3
<b>DESCRIPTION:</b>	OIL TANKER™ POLYETHYLENE OIL SEPARATOR WITH CLEAN SWEEP™ COALESCING MEDIA 750 GALLON CAPACITY
<b>DWG BY:</b>	WLF
<b>DATE:</b>	6/15/2021
<b>REV:</b>	0
<b>ECO:</b>	

**SPECIFICATION SHEET**

**Striem**  
 3100 Brinkerhoff  
 Kansas City, KS 66115  
 Tel: 913-222-1500  
 orders@striemco.com  
 www.striemco.com



Made in the U.S.A

PROPRIETARY AND CONFIDENTIAL  
 THE INFORMATION CONTAINED IN THIS DRAWING IS THE SOLE PROPERTY OF STRIEM, LLC.  
 ANY REPRODUCTION IN PART OR AS A WHOLE WITHOUT THE WRITTEN PERMISSION OF STRIEM, LLC. IS PROHIBITED.