

SPECIFICATIONS

- 3" Plain end vents standard.
- Max flow rate: 314 GPM
- Max flow rate to achieve 5 ppm of residual light liquid in effluent: 45 GPM
- Liquid capacity: 1000 Gallons (133.7 cu. ft.)
- Oil capacity: 370 Gallons
- Solids/sediment capacity: 239 Gallons
- Unit weight: 1424 lbs.
- H2O rated cast iron covers.
- Maximum operating temperature 140°F continuous.
- For buried applications only.

ENGINEER SPECIFICATION GUIDE

Striem Oil Tanker™ model OT-1000-CS3 shall be lifetime guaranteed and made in USA of High Density Polyethylene. Separator shall be furnished for below grade installation with field adjustable riser system. Separator flow rate shall be 314 GPM. Separator oil capacity shall be 370 gallons. Sand capacity shall be 239 gallons. Separator shall be certified to IAPMO IGC 183-2016.

Clean Sweep™ polypropylene coalescing media has been third party tested to performance standard CEN EN858-1 for class 1 coalescing separators.

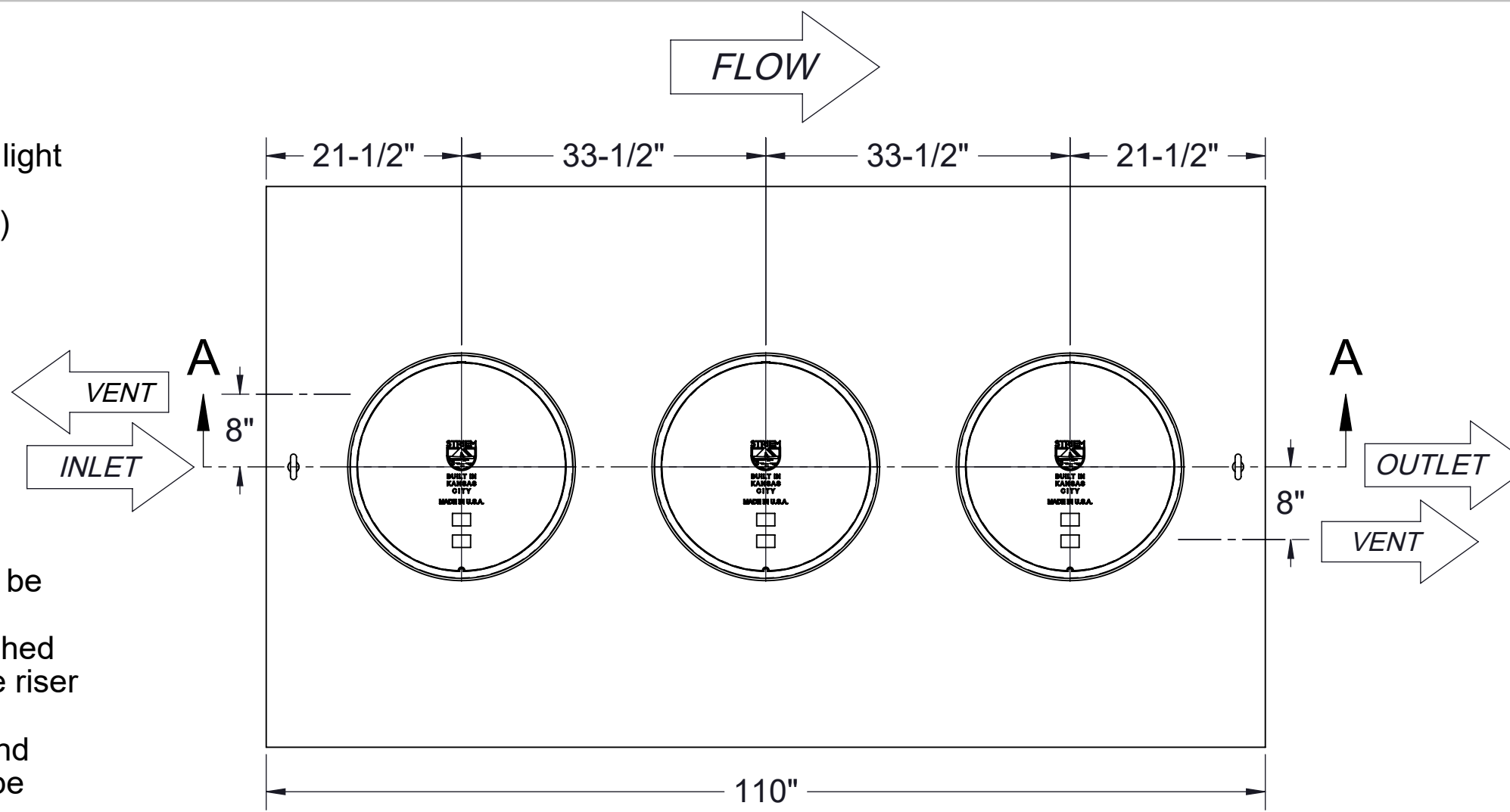

TOP VIEW

Directions: Choose connections, select options, sign and submit with purchase order.

Connections	Size
<input type="checkbox"/> Inlet / Outlet	<input type="checkbox"/> 4"
<input type="checkbox"/> Plain End	<input type="checkbox"/> 6"
<input type="checkbox"/> Male Thread	<input type="checkbox"/> 8" (Plain End Only)

Riser Options
Included : 0" - 5"
<input type="checkbox"/> SR24 (3) : >5" - 24"
<input type="checkbox"/> LR24 (3) : >24" - 39"
<input type="checkbox"/> SR24 (6) : >39" - 43"
<input type="checkbox"/> SR24 (3) + LR24 (3) : >43" - 58"
<input type="checkbox"/> LR24 (6) : >58" - 72"
<input type="checkbox"/> SR24 (3) + LR24 (6) : >72" - 90"
<input type="checkbox"/> LR24 (9) : >90" - 106"

Additional Options
<input type="checkbox"/> HDK-1000 : High Water Table Hold Down Kit
<input type="checkbox"/> SS : Slick Stick™ Oil Level Monitoring System*
*Monitoring system will raise covers by 3".

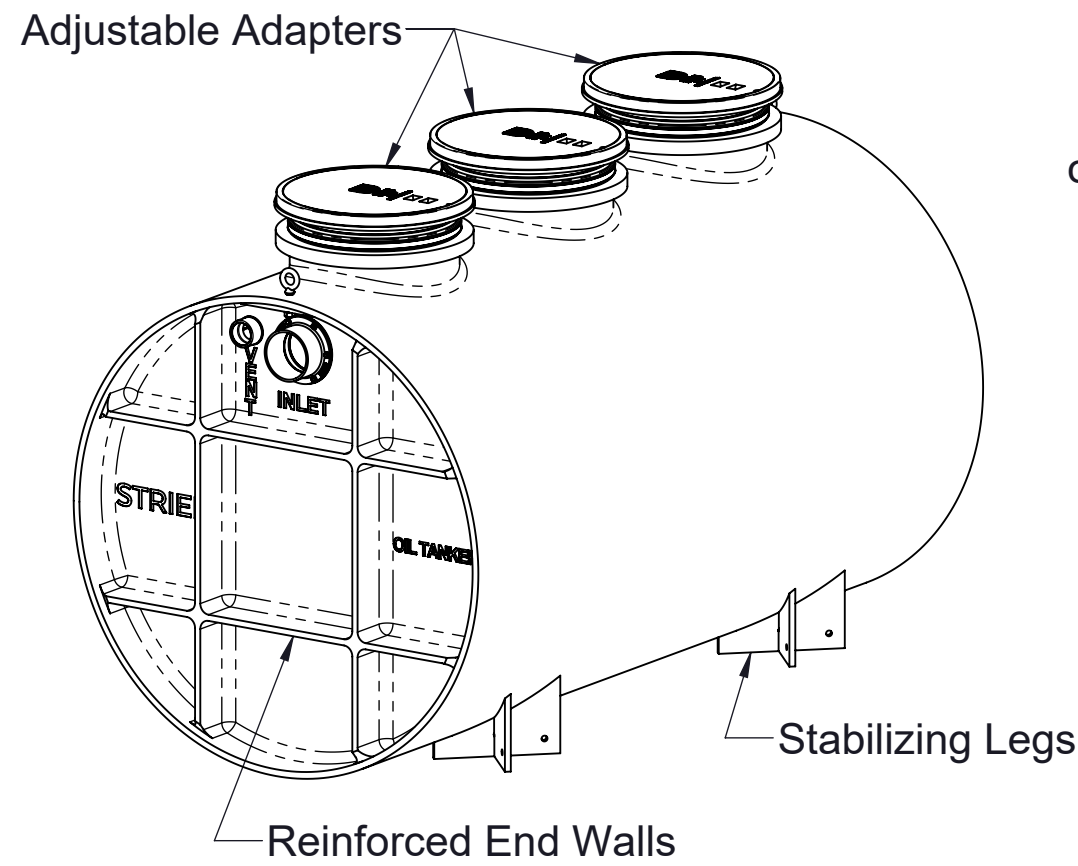

ISOMETRIC VIEW

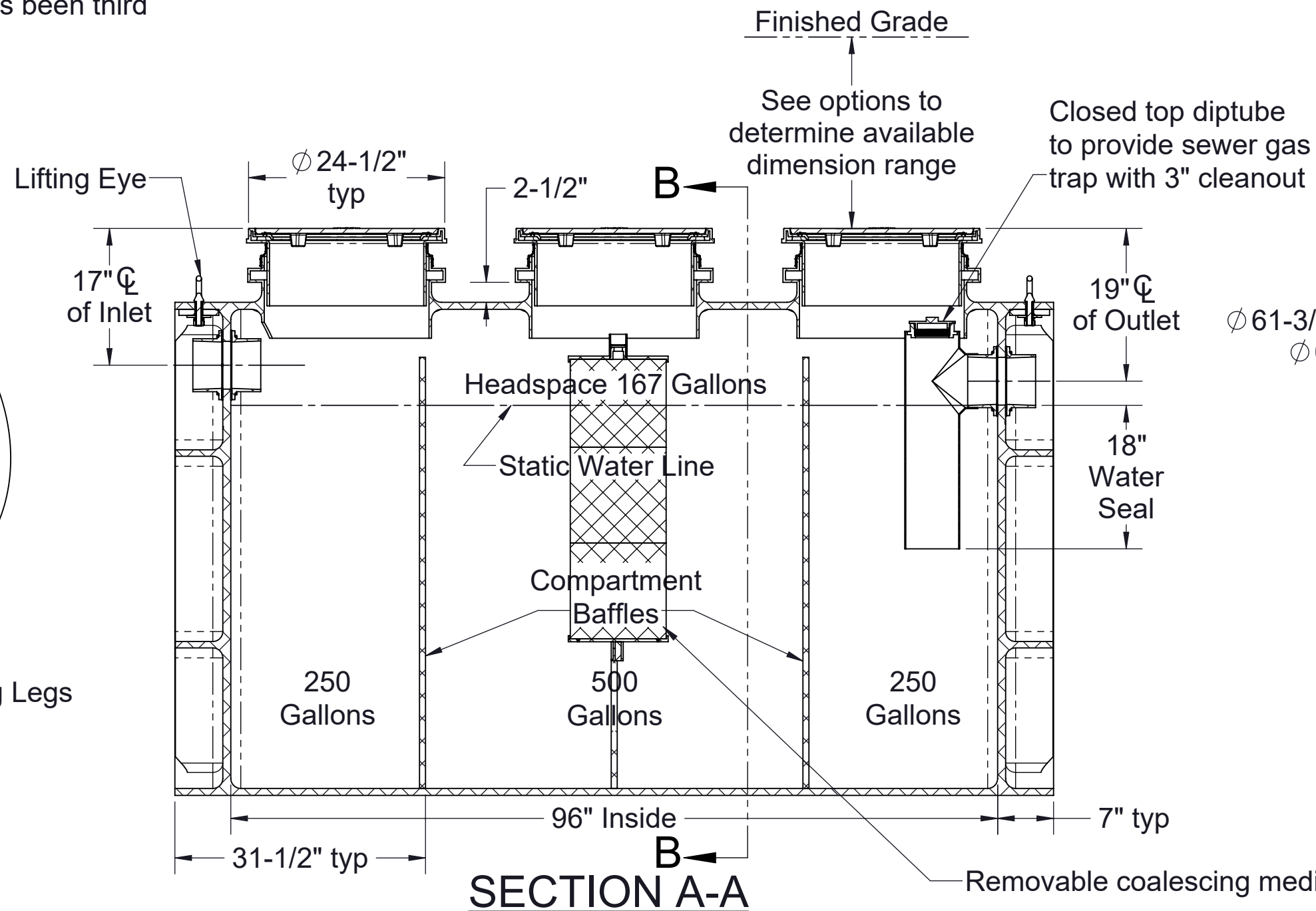

SECTION A-A

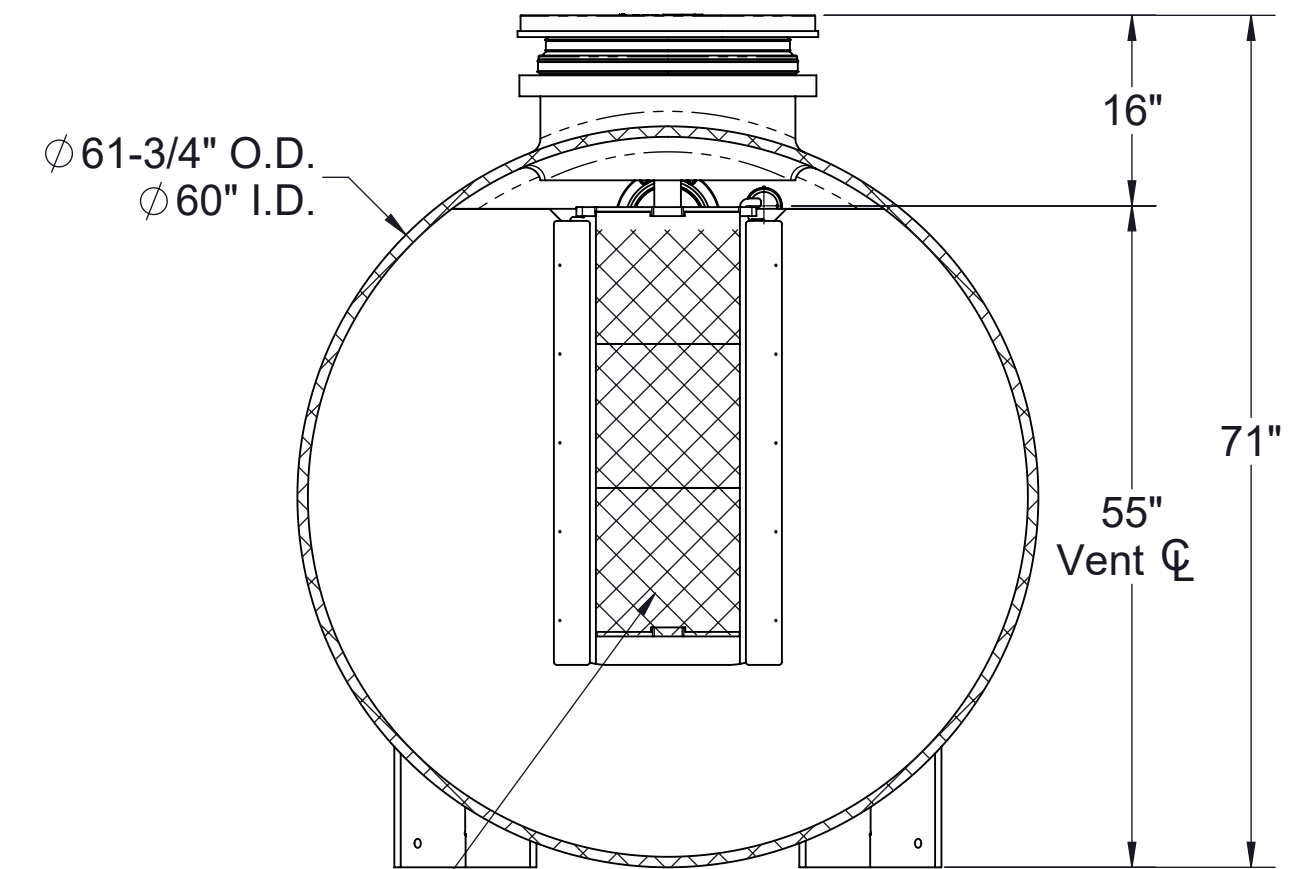

SECTION B-B

Signature of Approval: _____
 Company: _____
 Date of Approval: _____
 Specifying Engineer: _____
 Engineering Firm: _____

PO IS NON-CANCELABLE
 ORDER IS NON-RETURNABLE

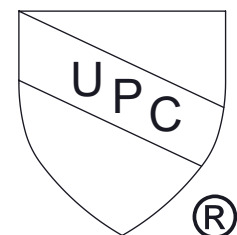

MODEL NUMBER: OT-1000-CS3
DESCRIPTION: OIL TANKER™ POLYETHYLENE OIL SEPARATOR WITH CLEAN SWEEP™ COALESCING MEDIA 1000 GALLON CAPACITY
DWG BY: MJ DATE: 01/28/2022 REV: 0 ECO:

SPECIFICATION SHEET

Striem
 3100 Brinkerhoff
 Kansas City, KS 66115
 Tel: 913-222-1500
 orders@striemco.com
 www.striemco.com



Made in the U.S.A

PROPRIETARY AND CONFIDENTIAL
 THE INFORMATION CONTAINED IN THIS DRAWING IS THE SOLE PROPERTY OF STRIEM, LLC.
 ANY REPRODUCTION IN PART OR AS A WHOLE WITHOUT THE WRITTEN PERMISSION OF STRIEM, LLC. IS PROHIBITED.