

SPECIFICATIONS

1. 3" Plain end vents standard.
2. Max flow rate: 314 GPM
3. Liquid capacity: 1500 Gallons (201 cu. ft.)
4. Oil capacity: 488 Gallons
5. Solids/sediment capacity: 825 Gallons
6. Unit weight: 1676 lbs.
7. H2O rated cast iron covers.
8. Maximum operating temperature 140°F continuous.
9. For buried applications only.

ENGINEER SPECIFICATION GUIDE

Striem Oil Tanker™ model OT-1500 shall be lifetime guaranteed and made in USA of High Density Polyethylene. Separator shall be furnished for below grade installation with field adjustable riser system. Separator flow rate shall be 314 GPM. Separator oil capacity shall be 488 gallons. Sand capacity shall be 825 gallons. Separator shall be certified to IAPMO IGC 183-2016.

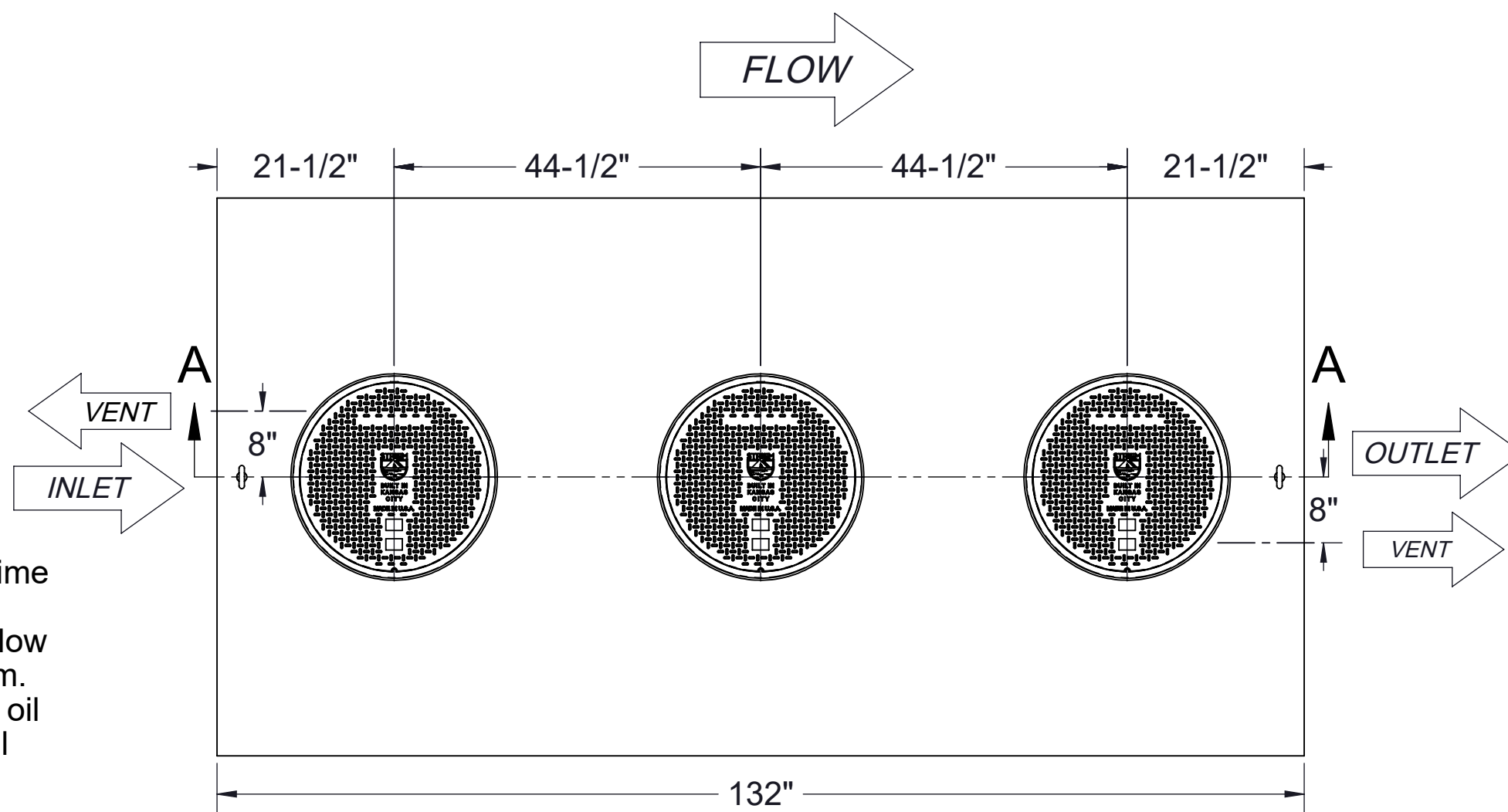

TOP VIEW

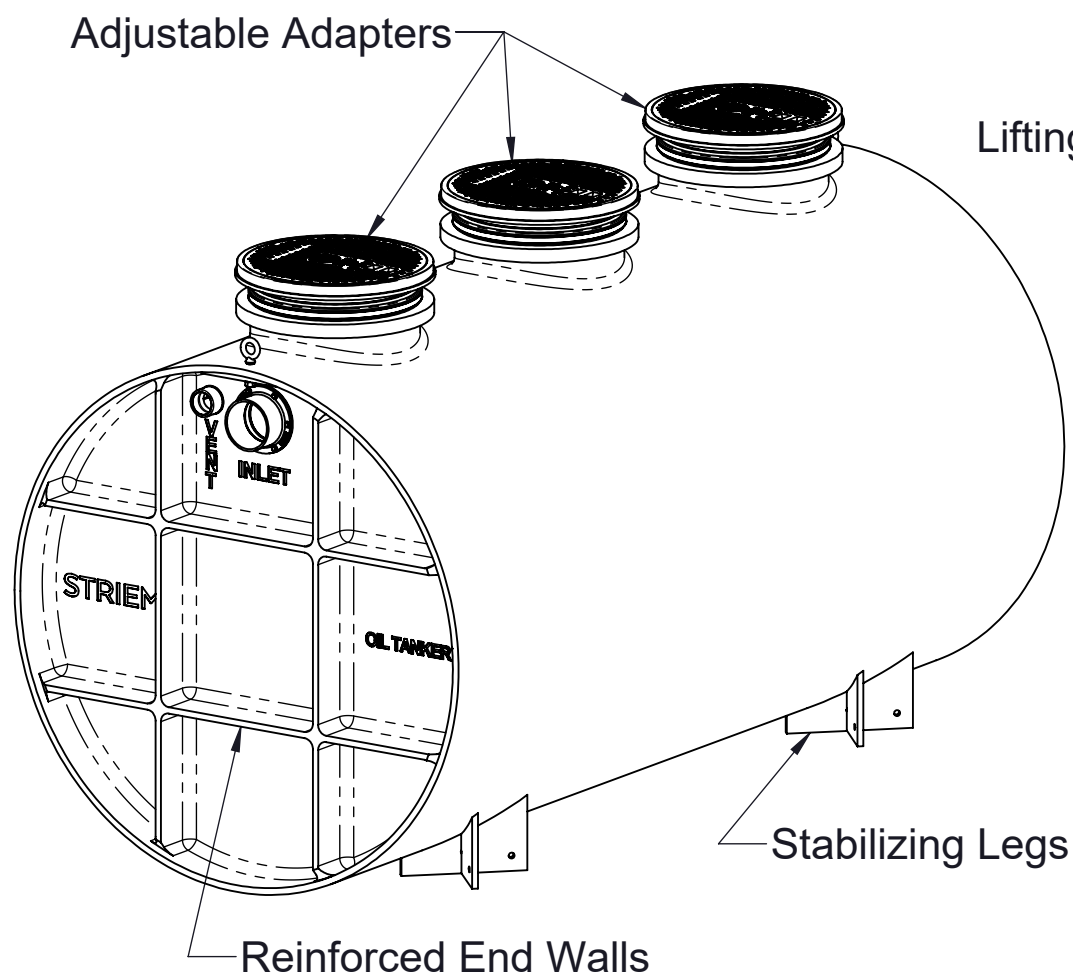

ISOMETRIC VIEW

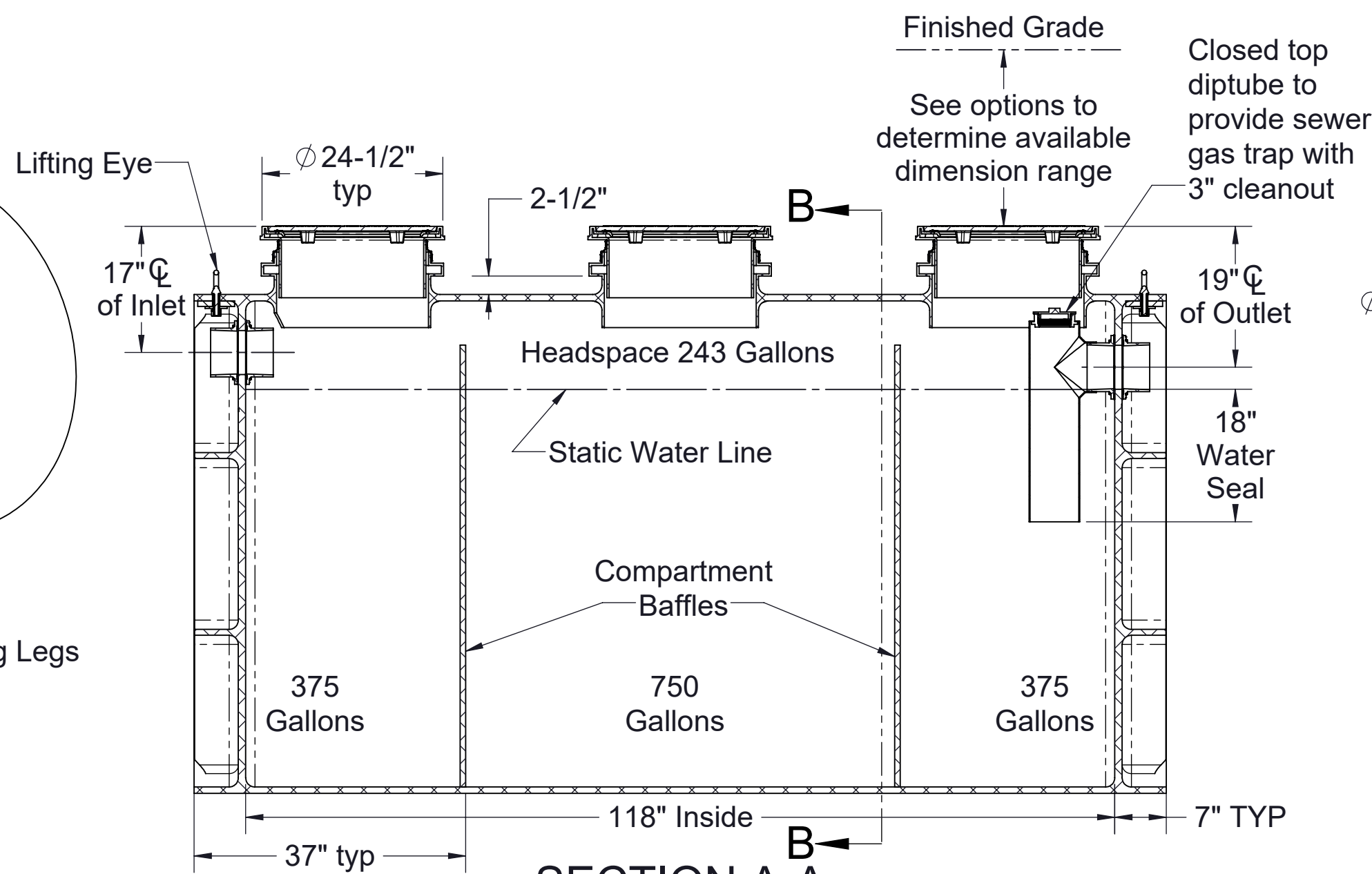

SECTION A-A

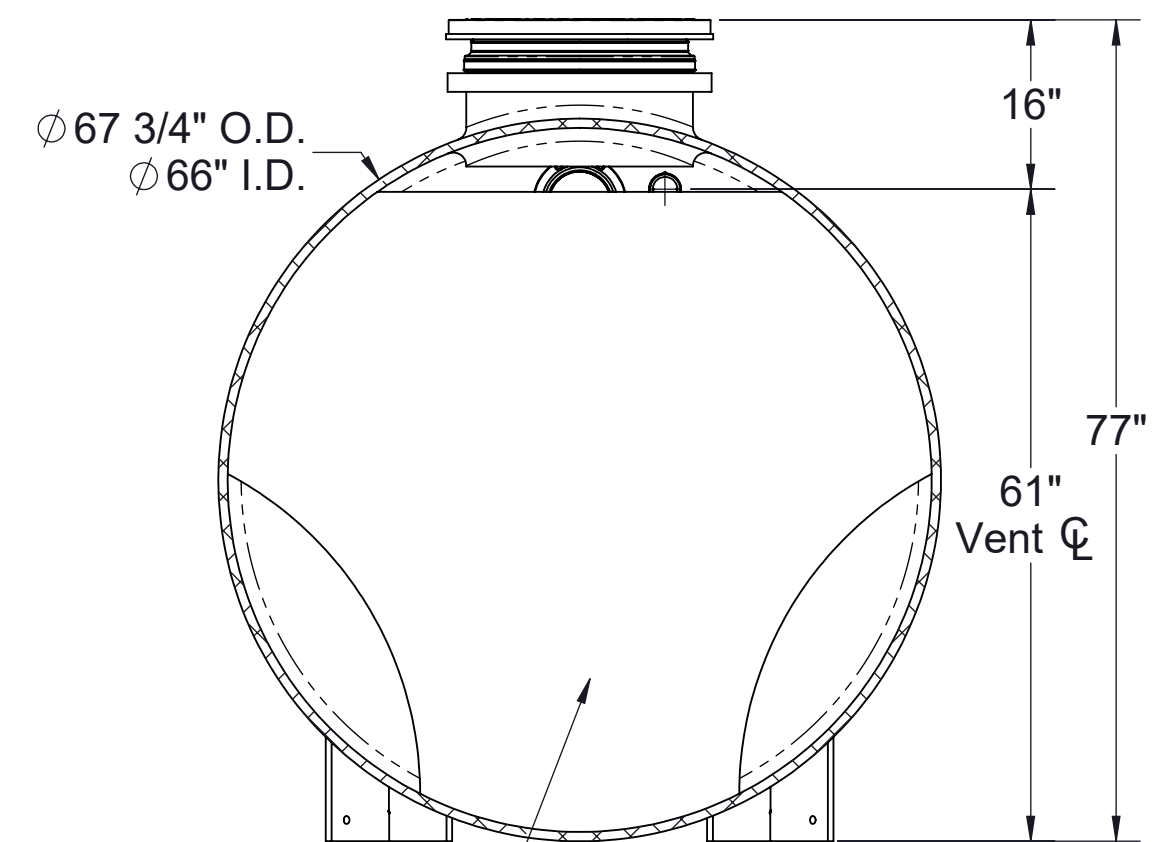

SECTION B-B

Directions: Choose connections, select options, sign and submit with purchase order.

Connections

- | | |
|--------------------------------------|--|
| Inlet / Outlet | Size |
| <input type="checkbox"/> Plain End | <input type="checkbox"/> 4" |
| <input type="checkbox"/> Male Thread | <input type="checkbox"/> 6" |
| | <input type="checkbox"/> 8" (Plain End Only) |

Riser Options

- Included : 0" - 5"**
- SR24 (3) :** >5" - 24"
 - LR24 (3) :** >24" - 39"
 - SR24 (6) :** >39" - 43"
 - SR24 (3) + LR24 (3) :** >43" - 58"
 - LR24 (6) :** >58" - 72"
 - SR24 (6) + LR24 (3) :** >72" - 90"
 - LR24 (9) :** >90" - 106"

- OR -

- CPRK (3) :** >11" - 106"
 - Corrugated Pipe Riser Kit.
 - 18" diameter corrugated pipe by others.
 - See CPRK specification for more detail.

Additional Options

- HDK-1500 :** High Water Table Hold Down Kit
 - SS :** Slick Stick™ Oil Level Monitoring System*
- *Monitoring system will raise covers by 3".

Signature of Approval: _____
 Company: _____
 Date of Approval: _____
 Specifying Engineer: _____
 Engineering Firm: _____

PO IS NON-CANCELABLE
 ORDER IS NON-RETURNABLE

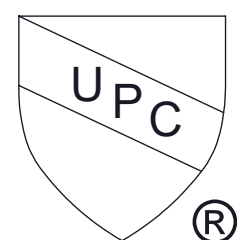

MODEL NUMBER:	OT-1500
DESCRIPTION:	OIL TANKER™ POLYETHYLENE OIL SEPARATOR 1500 GALLON CAPACITY
DWG BY:	WLF
DATE:	6/15/21
REV:	0
ECO:	

SPECIFICATION SHEET

Striem
 3100 Brinkerhoff
 Kansas City, KS 66115
 Tel: 913-222-1500
 orders@striemco.com
 www.striemco.com



Made in the U.S.A

PROPRIETARY AND CONFIDENTIAL

THE INFORMATION CONTAINED IN THIS DRAWING IS THE SOLE PROPERTY OF STRIEM, LLC. ANY REPRODUCTION IN PART OR AS A WHOLE WITHOUT THE WRITTEN PERMISSION OF STRIEM, LLC. IS PROHIBITED.