

**SPECIFICATIONS**

1. 3" Plain end vents standard.
2. Max flow rate: 314 GPM.
3. Liquid capacity: 750 gallons (100 cu. ft.).
4. Oil capacity: 323 gallons.
5. Solids capacity: 295 gallons.
6. Unit weight: 1293 lbs.
7. Maximum operating temperature 140°F continuous.
8. H2O rated pickable cast iron covers.

**NOTES**

1. For gravity drainage applications only. Do not use for pressure applications.
2. Cover placement allows full access to tank for proper maintenance.
3. Lifting lug set for easy install.
4. For below grade installation only.

**ENGINEER SPECIFICATION GUIDE**

Striem Oil Tanker™ model OT-750 shall be lifetime guaranteed and made in USA of High Density Polyethylene with 7/8" nominal wall thickness. Tank shall be furnished for below grade installation with field adjustable riser system. Separator flow rate shall be 314 GPM. Separator oil capacity shall be 323 gallons. Sand capacity shall be 295 gallons. Separator shall be certified to IAPMO IGC 183-2016.

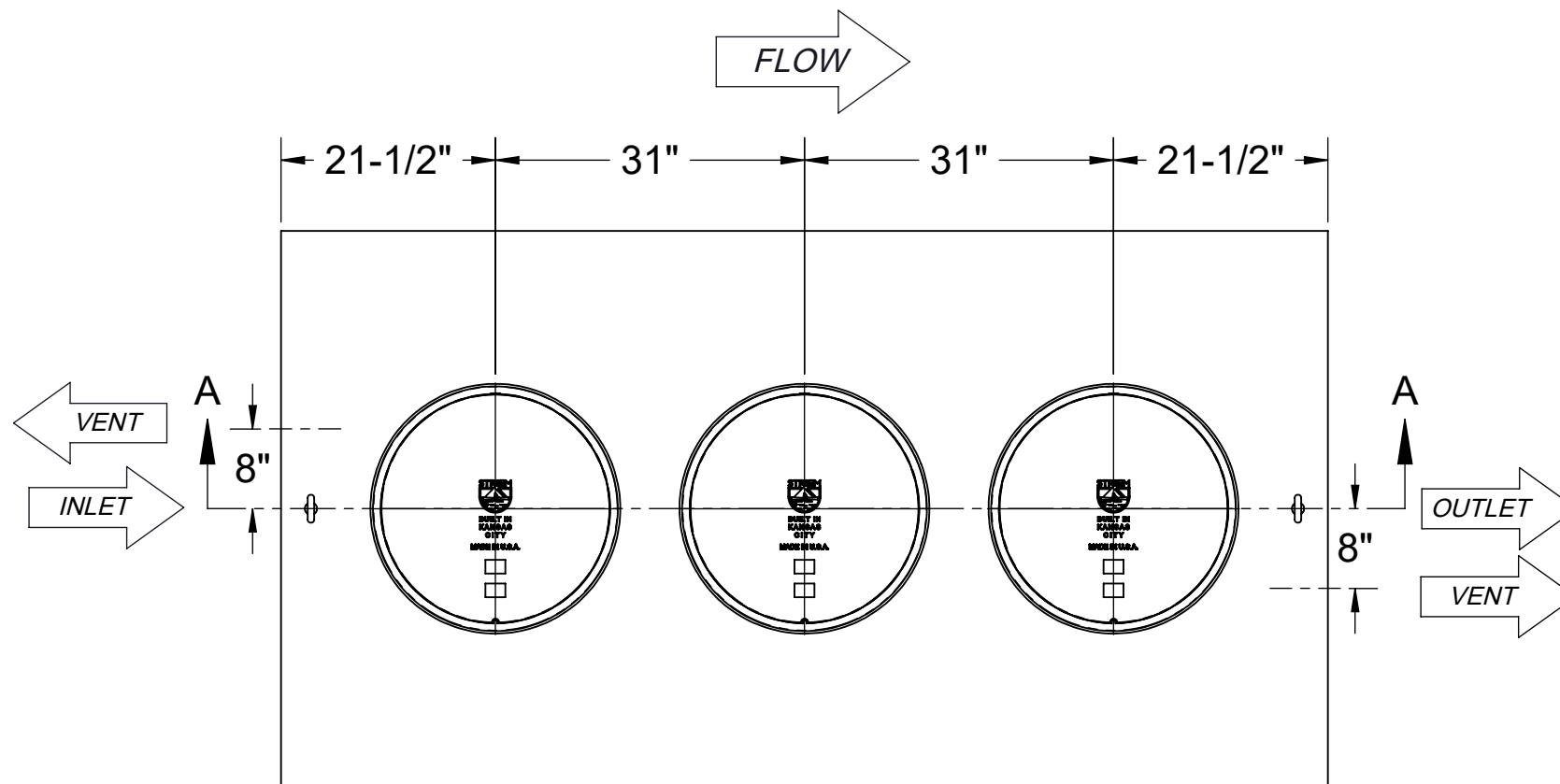

**TOP VIEW**

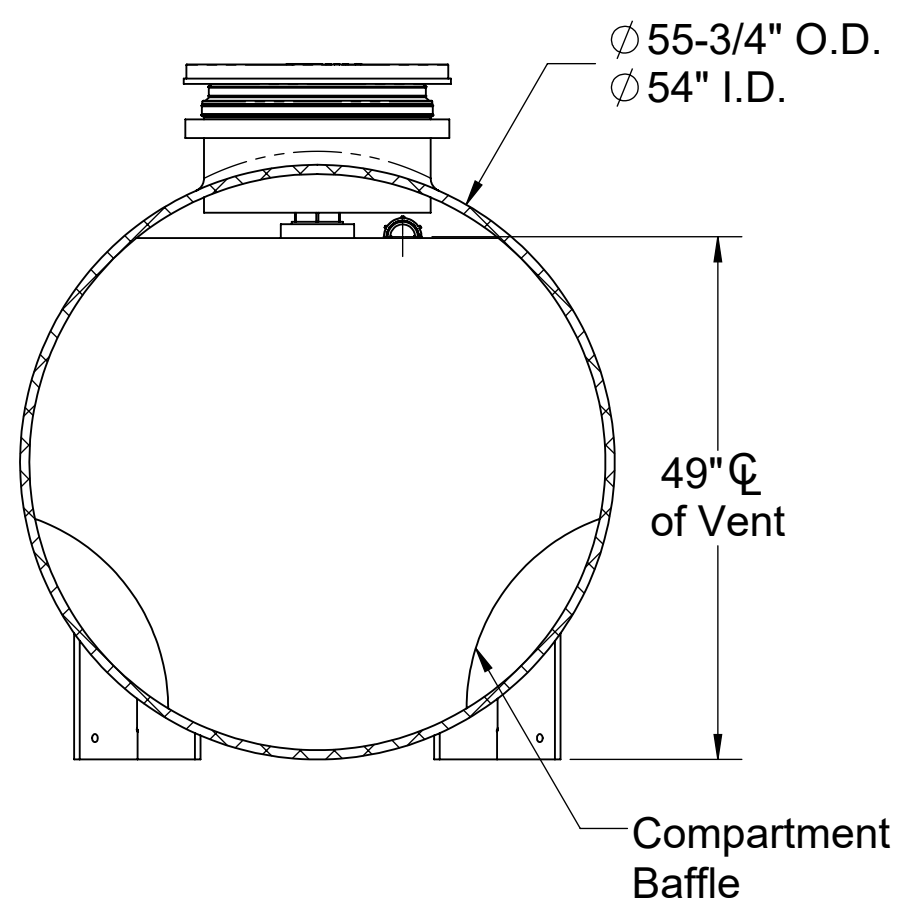

**SECTION B-B**

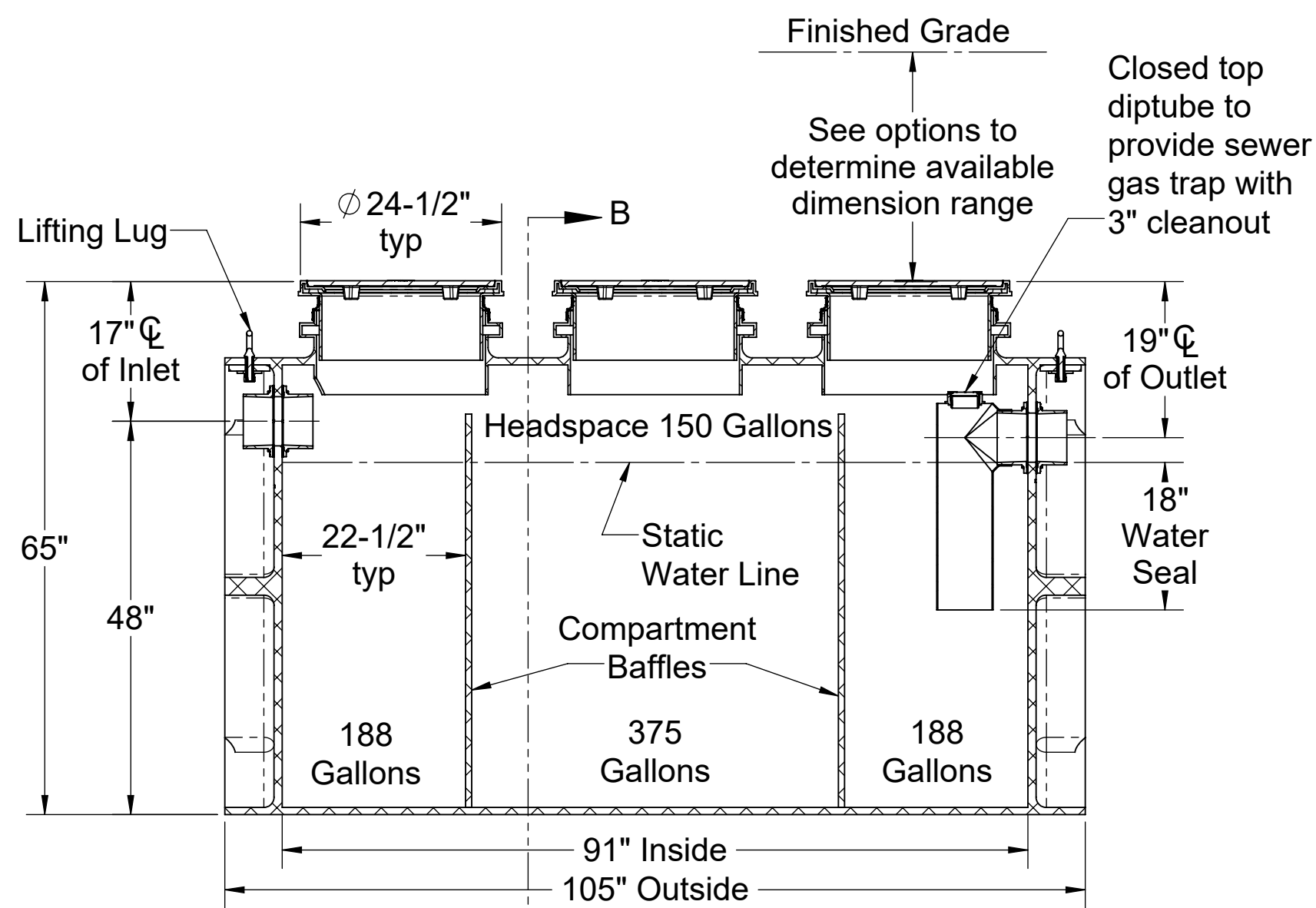

**SECTION A-A**

**Directions: Complete steps 1-3 and submit signed with purchase order.**

**1. Connections**

| Inlet / Outlet                       | Size   |
|--------------------------------------|--|
| <input type="checkbox"/> Plain End   | <input type="checkbox"/> 4"                  |
| <input type="checkbox"/> Male Thread | <input type="checkbox"/> 6"                  |
|                                      | <input type="checkbox"/> 8" (Plain End Only) |

**2. Riser Options**

- Included: 0" - 5"**
- SR24** (3): 5" - 24"
  - LR24** (3): 24" - 39"
  - SR24** (6): 39" - 43"
  - SR24** (3) + **LR24** (3): 43" - 58"
  - LR24** (6): 58" - 72"
  - SR24** (3) + **LR24** (6): 72" - 90"
  - LR24** (9): 90" - 106"

**- OR -**

- CPRK** (3): 11" - 106"
  - Corrugated Pipe Riser Kit.
  - 18" diameter corrugated pipe by others.
  - See CPRK specification for more detail.

**3. Additional Options**

- HDK-4**: High Water Table Hold Down Kit
  - SS**: Slick Stick™ Oil Level Monitoring System\*
  - CS3**: Clean Sweep Coalescing Media\*\*
- \*Monitoring system will raise covers by 3".  
 \*\*Clean Sweep Coalescing Media not compatible with CPRK

Signature of Approval: \_\_\_\_\_  
 Company: \_\_\_\_\_  
 Date of Approval: \_\_\_\_\_  
 Specifying Engineer: \_\_\_\_\_  
 Engineering Firm: \_\_\_\_\_

PO IS NON-CANCELABLE  
 ORDER IS NON-RETURNABLE

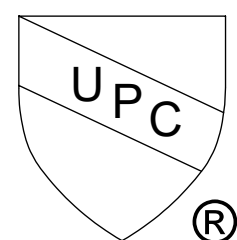

|                      |  |
|----------------------|--|
| <b>MODEL NUMBER:</b> | OT-750   |
| <b>DESCRIPTION:</b>  | OIL TANKER™<br>POLYETHYLENE OIL SEPARATOR<br>750 GALLON CAPACITY |
| <b>DWG BY:</b>       | WLF  |
| <b>DATE:</b>         | 6/8/22   |
| <b>REV:</b>          | 0  |
| <b>ECO:</b>          |  |

**SPECIFICATION SHEET**

**Striem**  
 3100 Brinkerhoff  
 Kansas City, KS 66115  
 Tel: 913-222-1500  
 orders@striemco.com  
 www.striemco.com

**Made in the U.S.A**

PROPRIETARY AND CONFIDENTIAL  
 THE INFORMATION CONTAINED IN THIS DRAWING IS THE SOLE PROPERTY OF STRIEM, LLC.  
 ANY REPRODUCTION IN PART OR AS A WHOLE WITHOUT THE WRITTEN PERMISSION OF STRIEM, LLC. IS PROHIBITED.