

SPECIFICATIONS

1. 3" Plain End inlet/outlet
2. Liquid Capacity: 38 gal.
3. Solids Capacity: 19 gal.
4. Unit weight with standard cover: 83 lbs.
5. Maximum operating temperature 140 °F continuous.
6. Pedestrian rated cover: 2,000 lb. capacity.

NOTES

1. For gravity drainage applications only. Do not use for pressure applications.
2. 3/8" seamless polyethylene tank.
3. Unit supplied with built-in adapter for up to 5" of adjustability. Additional riser(s) available for deeper burial depth.
4. Cover placement allows full access to tank for proper maintenance.
5. Internal components are removable for easy maintenance.
6. For on the-floor or buried applications.

ENGINEER SPECIFICATION GUIDE

Striem Prospector™ solids interceptor model PS-35-S shall be lifetime guaranteed and Made in USA of seamless, rotationally-molded Medium Density Polyethylene with minimum 3/8" uniform wall thickness. Interceptor shall be furnished for above or below-grade installation. Interceptor shall be furnished with connection for extending handle for deep burials. Cover shall provide water/gas-tight seal and have a maximum 2,000 lbs load capacity.

OPTIONS

- 2P:** 2" Plain end inlet/outlet
- 2M:** 2" Male thread inlet/outlet
- 3M:** 3" Male thread inlet/outlet
- 4P:** 4" Plain end inlet/outlet
- 4M:** 4" Male thread inlet/outlet
- C:** Course filter screen (openings 0.3" x 0.27")
- M:** Medium filter screen (openings 0.1" x 0.08")
- F:** Fine filter screen (openings 0.03" x 0.025")

TeleGlide RISER OPTIONS

- Included: 0" - 5"
- SR24:** 5" - 24"
 - LR24:** 24" - 39"

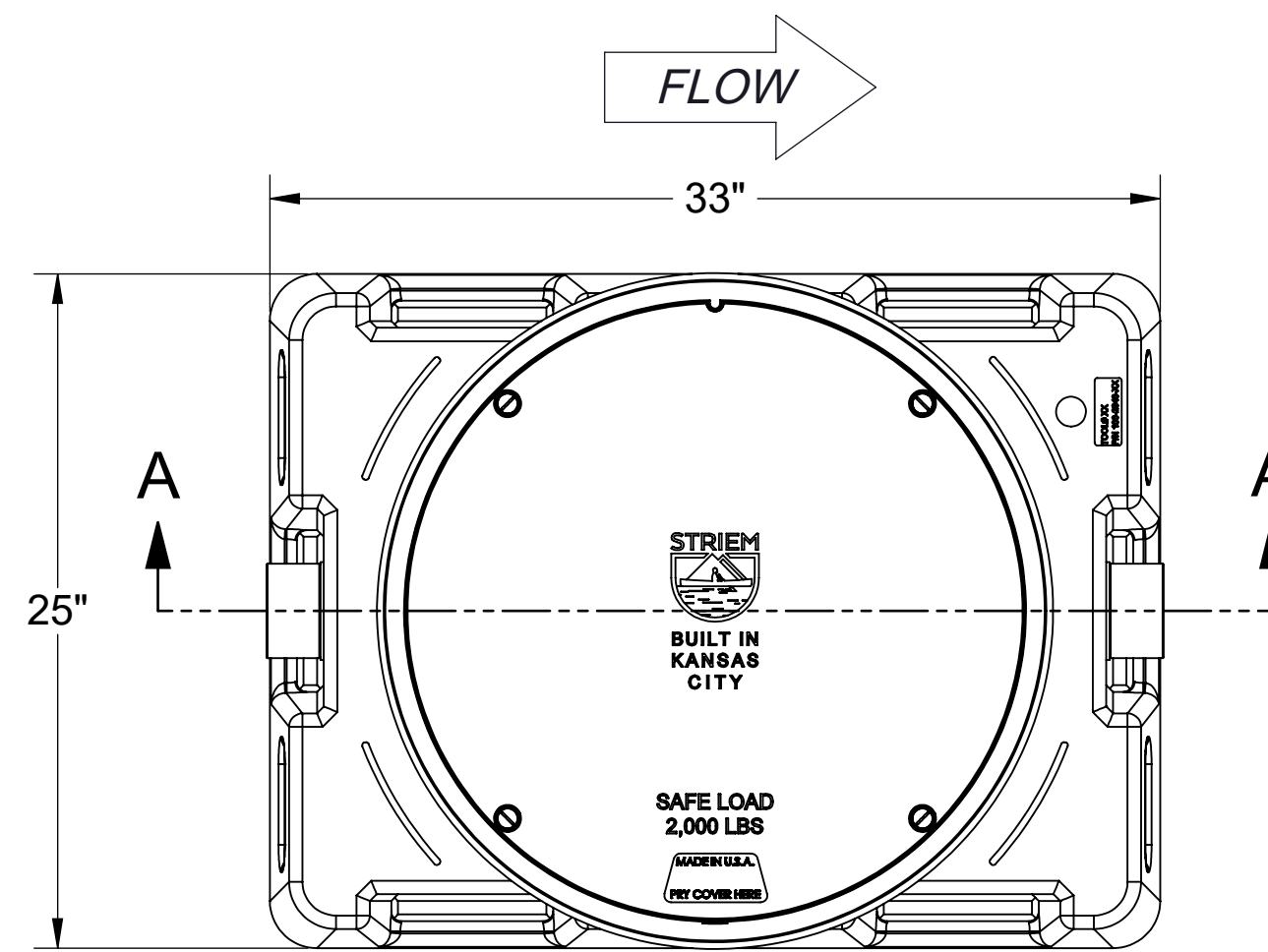

TOP VIEW

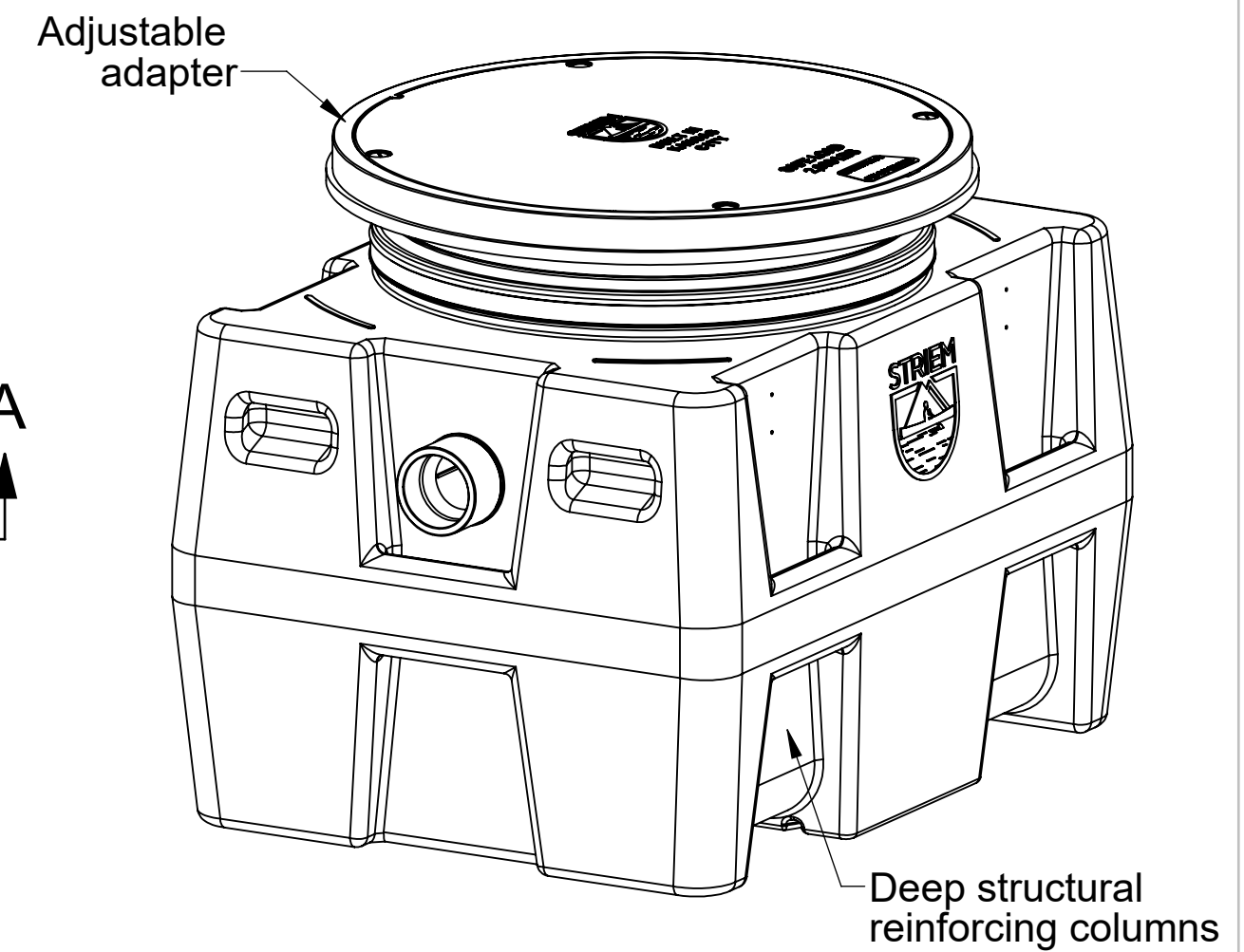

ISOMETRIC VIEW

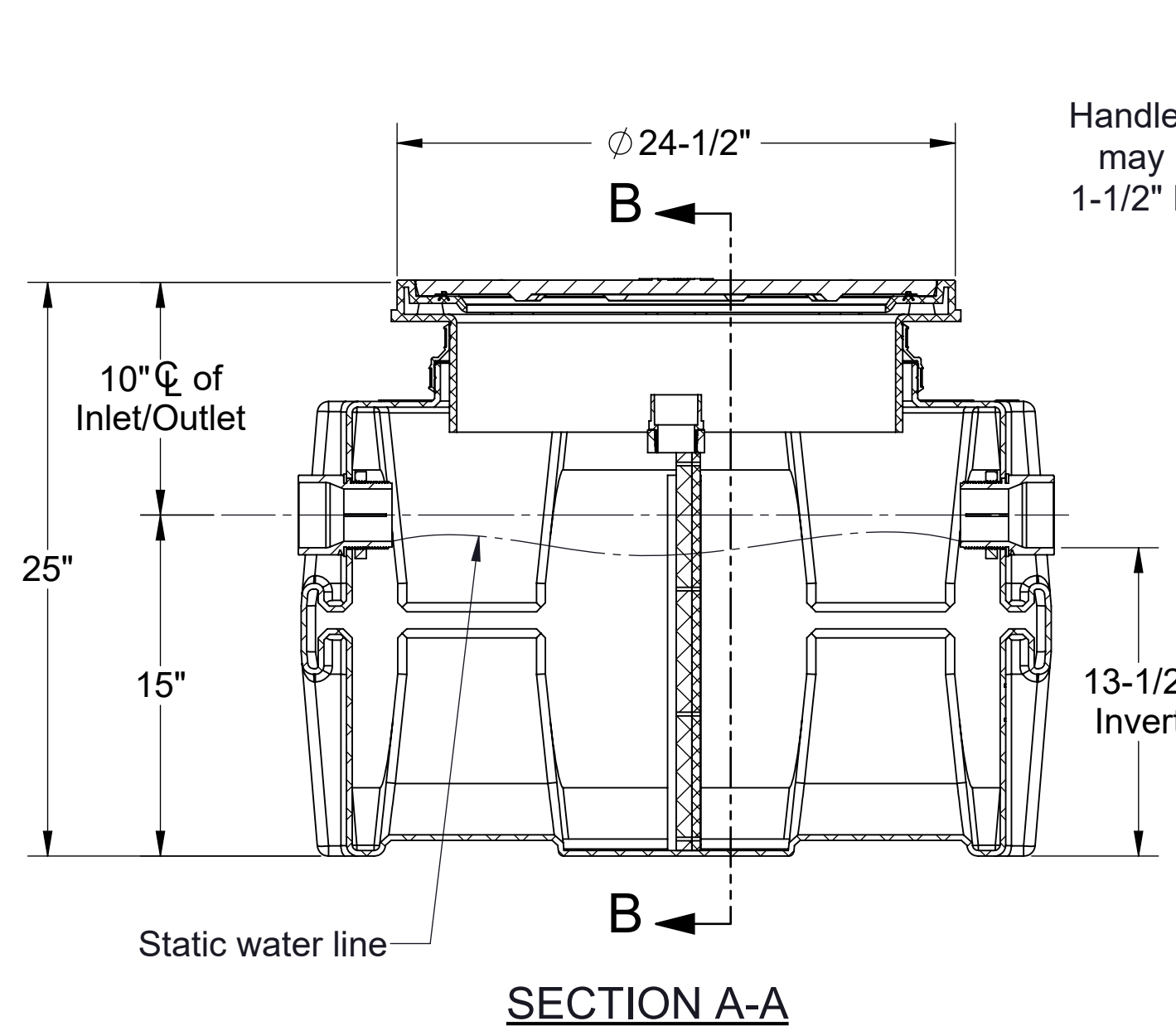

SECTION A-A

Handle of removable screen may be extended by using 1-1/2" PVC pipe. (by others)

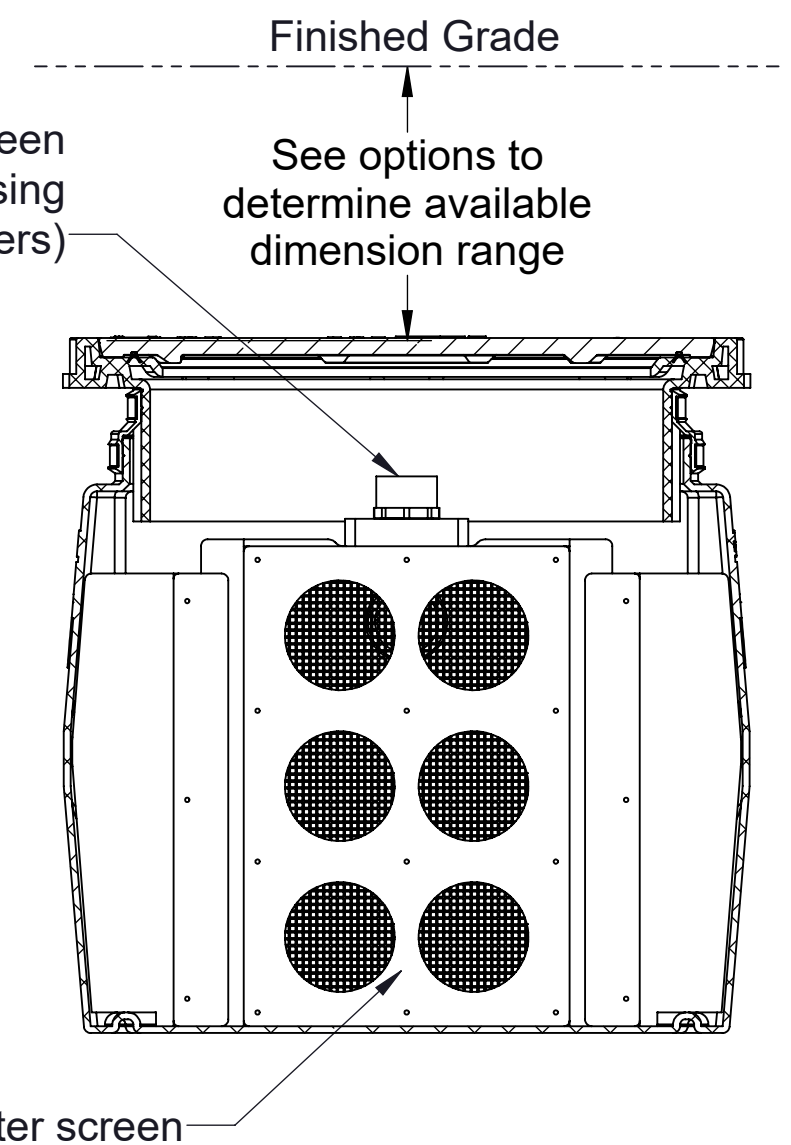

SECTION B-B

MODEL NUMBER: PS-35-S	
DESCRIPTION: PROSPECTOR SERIES POLYETHYLENE SCREEN STYLER SOLIDS INTERCEPTOR 38 GALLON LIQUID CAPACITY	
DWG BY: WLF	DATE: 4/29/22
REV: 1	ECO:

SPECIFICATION SHEET

Striem
3100 Brinkerhoff
Kansas City, KS 66115
Tel: 913-222-1500
orders@striemco.com
www.striemco.com



Made in the U.S.A

PROPRIETARY AND CONFIDENTIAL

THE INFORMATION CONTAINED IN THIS DRAWING IS THE SOLE PROPERTY OF STRIEM, LLC. ANY REPRODUCTION IN PART OR AS A WHOLE WITHOUT THE WRITTEN PERMISSION OF STRIEM, LLC. IS PROHIBITED.