

**SPECIFICATIONS**

1. 4" plain end inlet/outlet, 3" plain end vents.
2. Max flow rate: 43 GPM per 1016.3 of UPC.
3. Liquid capacity: 250 Gallons (33.4 cu ft).
4. Unit weight: 410 lbs.
5. (1) 28" H2O rated cast iron grate and (1) 23" H2O solid cast iron cover.
6. Seamless molded polyethylene tank.

**NOTES**

1. For gravity drainage applications only. Do not use for pressure applications.
2. Seamless medium density polyethylene tank.
3. Unit supplied with built-in adapter for up to 2-1/2" of adjustability. Additional riser(s) available for deeper burial depth.
4. Cover placement allows full access to tank for proper maintenance.
5. Narrow footprint allows clearance through doorways and down stairs.

**ENGINEER SPECIFICATION GUIDE**

Striem sand interceptor model SI-UPC-1016 shall be lifetime guaranteed and made in USA of seamless, rotationally-molded polyethylene. Interceptor shall be furnished for above or below grade installation, with field adjustable riser system, and vent connection. Unit shall have one grate cover over inlet section and one solid cover over outlet section. Each cover shall be traffic rated.

**THIRD PARTY STRUCTURAL ANALYSIS**

The SI-UPC-1016 has been structurally analyzed in accordance with the requirements of IBC 2012 and ASCE/SEI 7 for direct burial. The maximum burial depth and backfill material are specified in our installation instructions. The structural design has been reviewed and sealed by a professional engineer registered in the state of California. A sealed structural analysis report is available upon request.

**OPTIONS**

- 3M:** 3" Male Thread Inlet / Outlet
- 3P:** 3" Plain End Inlet / Outlet
- 4M:** 4" Male Thread Inlet / Outlet
- 6P:** 6" Plain End Inlet / Outlet
- 6M:** 6" Male Thread Inlet / Outlet
- HDK-2:** High Water Anchor Kit
- BCB-7:** 7 gallon capacity sediment basket with  $\phi$  1/4" perforations

**TeleGlide RISER OPTIONS**

Included: 0" - 2-1/2"

- SR24 (2):** 5"-24"
- LR24 (2):** 24"-39"
- SR24 (4):** 39"-43"
- SR24 (2) + LR24 (2):** 43"-58"
- LR24 (4):** 58"-72"
- SR24 (2) + LR24 (4):** 72"-90"

\*If in the range of 2-1/2"-5", contact Striem for a custom solution.

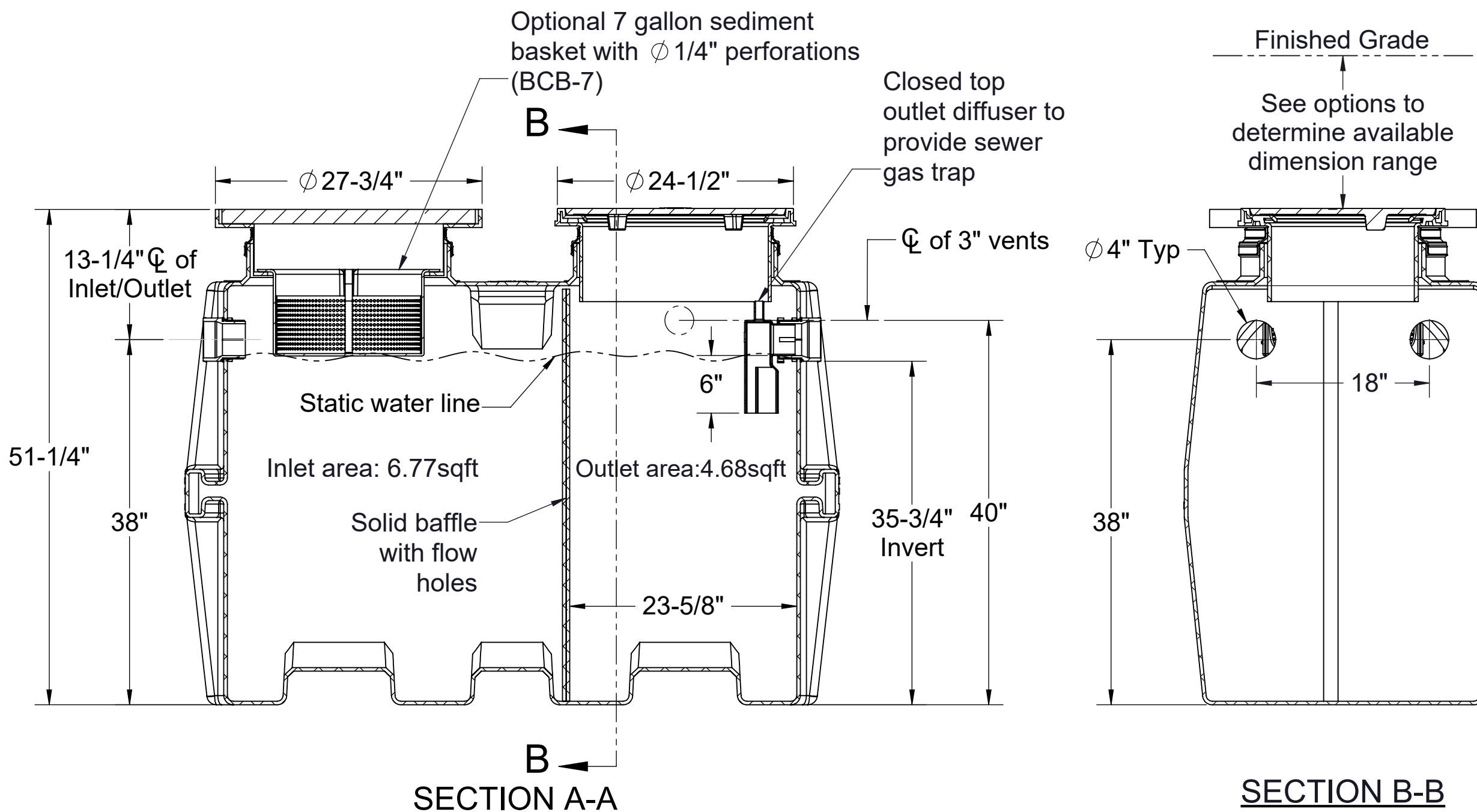
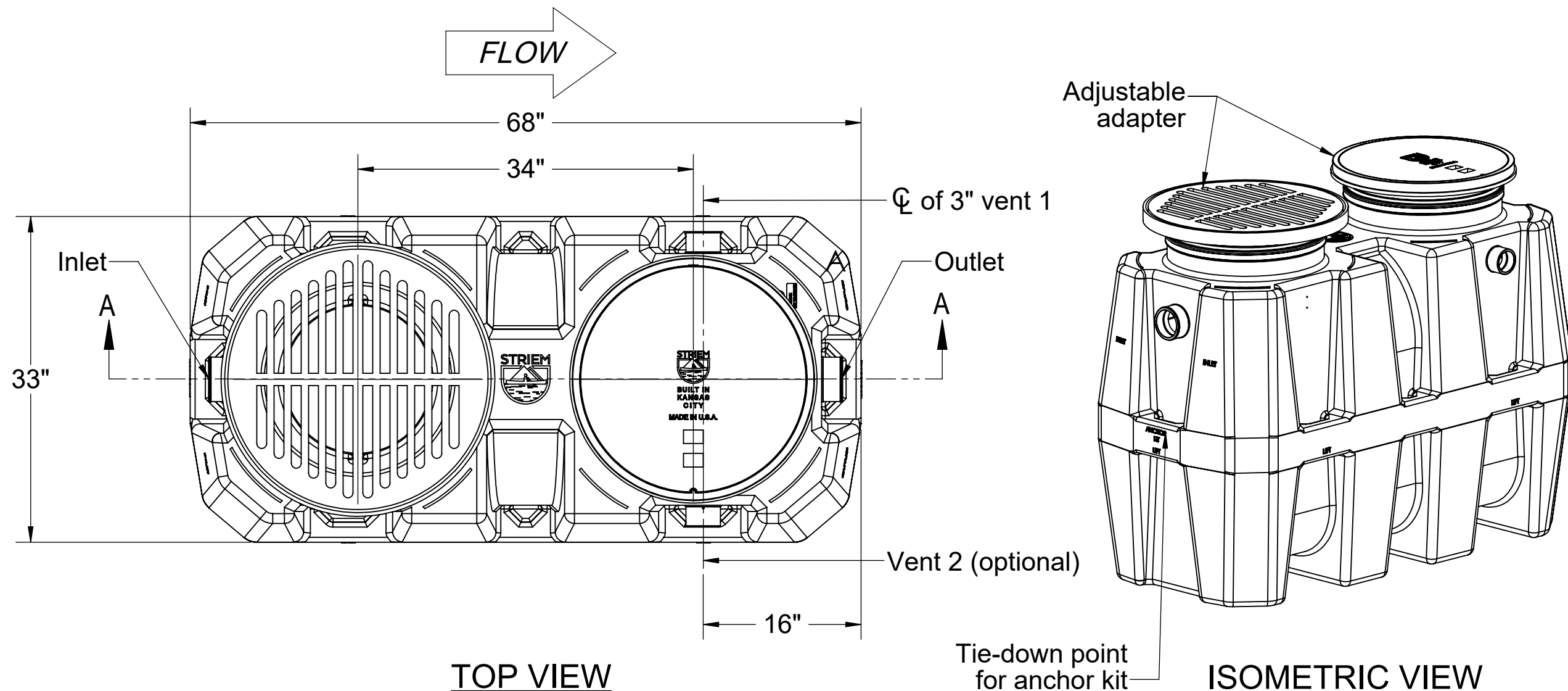

Signature of Approval: \_\_\_\_\_  
 Company: \_\_\_\_\_  
 Date of Approval: \_\_\_\_\_  
 Specifying Engineer: \_\_\_\_\_  
 Engineering Firm: \_\_\_\_\_

PO IS NON-CANCELABLE  
 ORDER IS NON-RETURNABLE

<b>MODEL NUMBER:</b> SI-UPC-1016	
<b>DESCRIPTION:</b> 250 GALLON SAND INTERCEPTOR DESIGNED PER SPECIFICATIONS LISTED IN UPC 1016.0.	
<b>DWG BY:</b> JC	<b>DATE:</b> 9/28/2022
<b>REV:</b> 0	<b>ECO:</b>

**SPECIFICATION SHEET**

**Striem**  
 3100 Brinkerhoff  
 Kansas City, KS 66115  
 Tel: 913-222-1500  
 orders@striemco.com  
 www.striemco.com

Made in the U.S.A

PROPRIETARY AND CONFIDENTIAL

THE INFORMATION CONTAINED IN THIS DRAWING IS THE SOLE PROPERTY OF STRIEM, LLC. ANY REPRODUCTION IN PART OR AS A WHOLE WITHOUT THE WRITTEN PERMISSION OF STRIEM, LLC. IS PROHIBITED.