

SPECIFICATIONS

1. 4" Plain End inlet/outlet standard.
2. Liquid holding capacity: 1 Gallon.
3. Unit weight: 10 lbs.
4. Maximum operating temperature 140°F continuous.

NOTES

1. For above grade placement of pH probe for CC-1 Command Center monitoring package.
2. For gravity drainage applications only.
3. Do not use for pressure applications.
4. Unit for above-grade installation.

OPTIONS

Connection Options (Plain End Only)

- 2"
- 3"
- 4"
- 6"

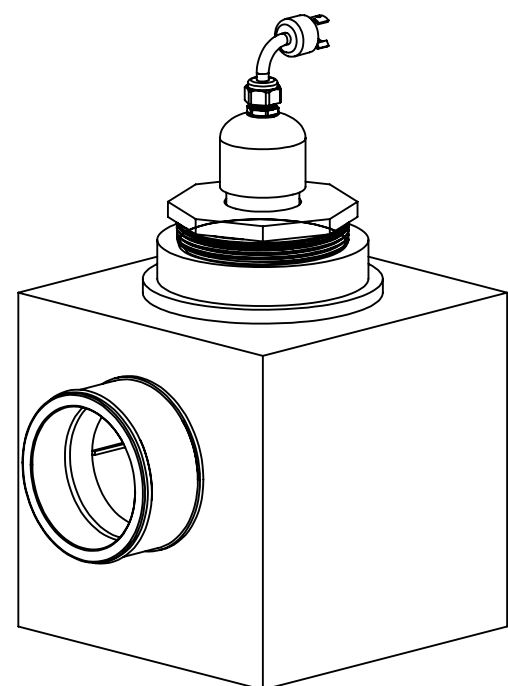
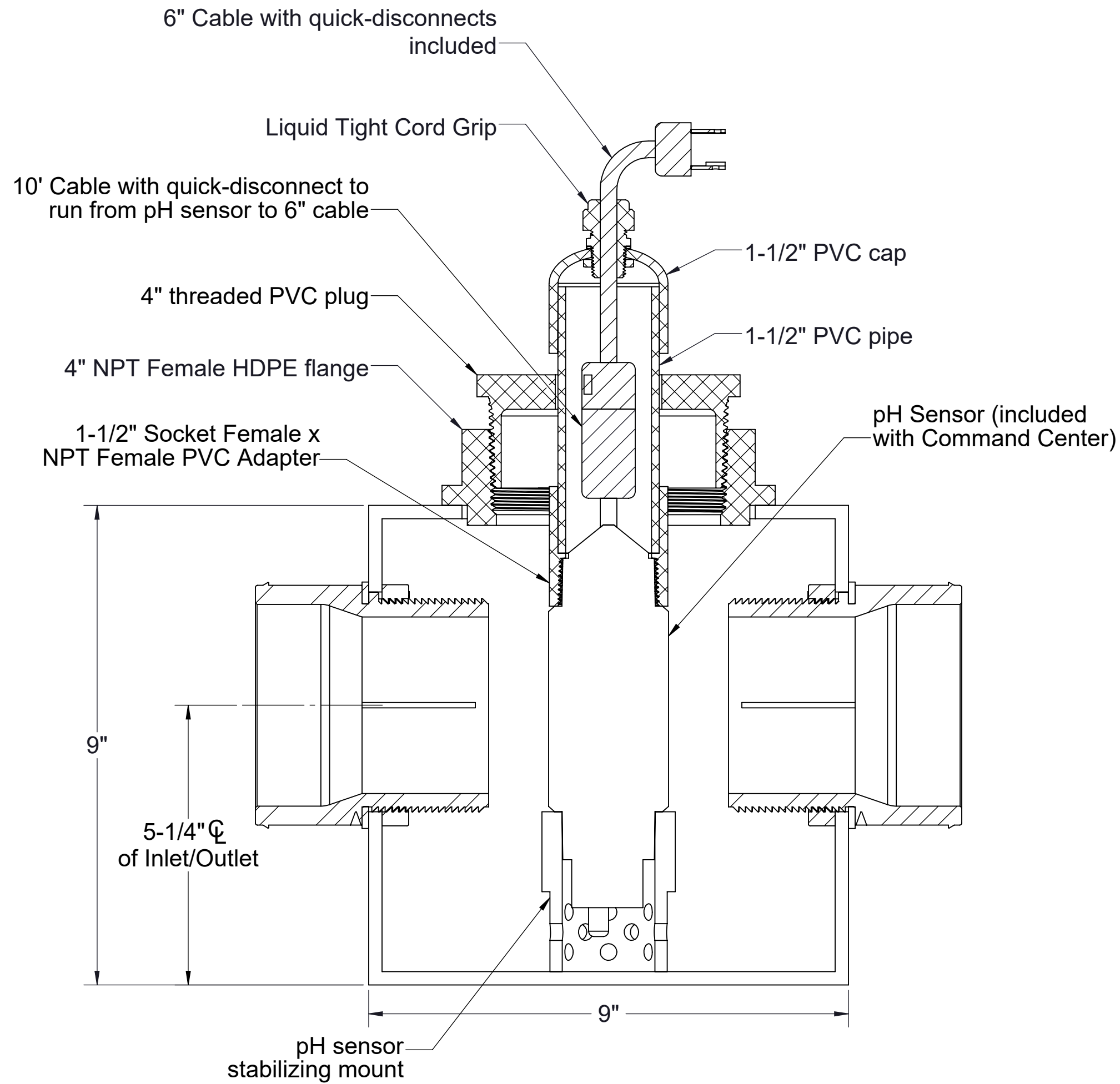

MODEL NUMBER: SPK-A

DESCRIPTION:
 SENSOR PLACEMENT KIT
 FOR ABOVE-GRADE USE

DWG BY: ENG **DATE:** 10/11/2023 **REV:** 0

SPECIFICATION SHEET

Striem
 Kansas City, KS
 Tel: 913-222-1500
 orders@striemco.com
 www.striemco.com

Made in the U.S.A

