

SPECIFICATIONS (SPK-A)

1. Liquid holding capacity: 1 Gallon.
2. Maximum operating temperature 140 °F continuous.

NOTES

1. For above grade placement of pH probe for CC-1 or CC-2 pH Command Center monitoring package.
Do not use for pressure applications.
2. For gravity drainage applications only.
3. 3/8" thick seamless medium density polyethylene walls.
4. Unit for above grade installation.

OPTIONS

Connection Type

- Plain End
- Female Thread
- Flanged

Size

- 1-1/2"
- 2"
- 3"
- 4"
- 6" (Female Thread not available)

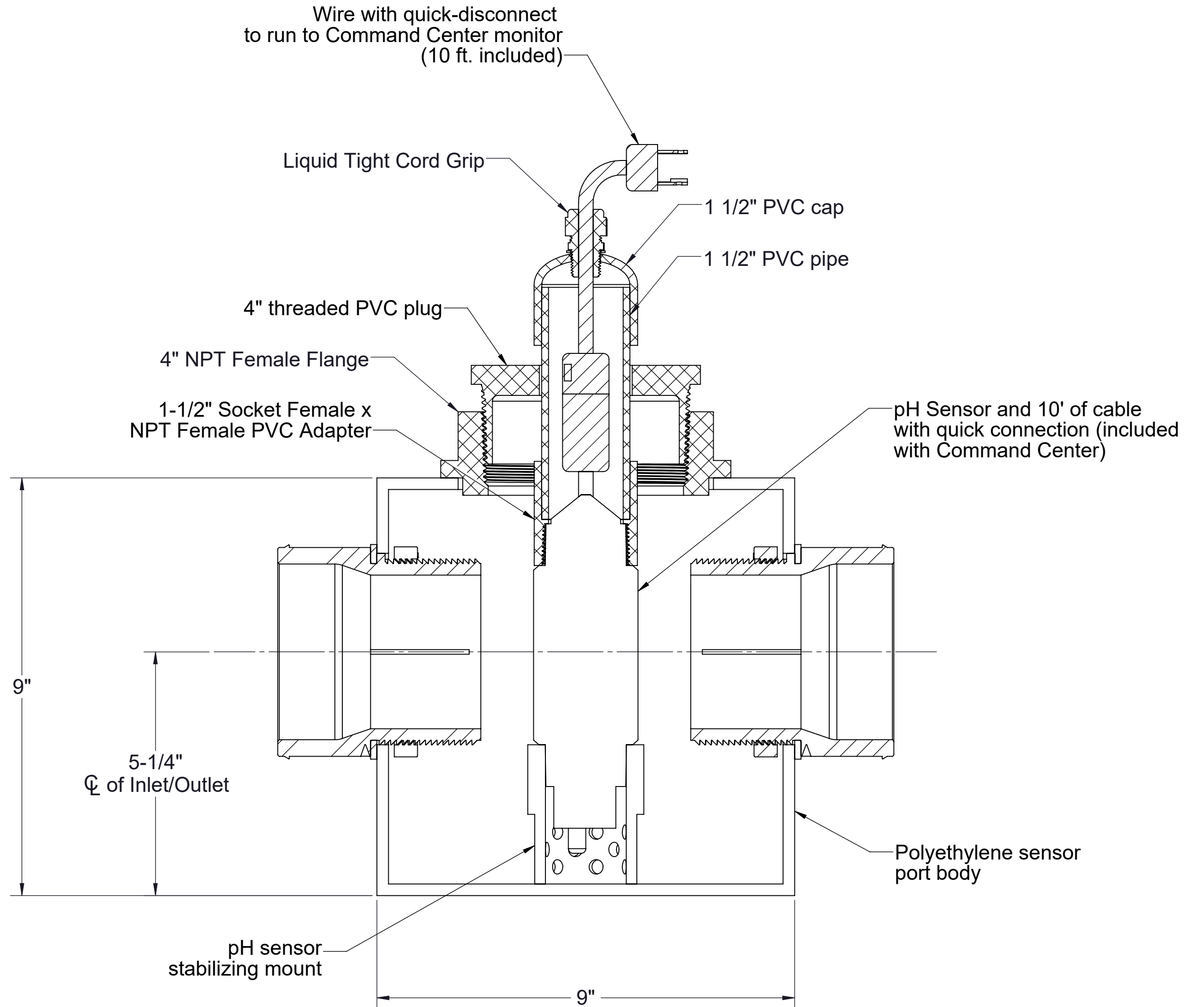

MODEL NUMBER: SPK-A	
DESCRIPTION: ABOVE GRADE pH SENSOR PLACEMENT KIT	
DWG BY: MJ	DATE: 03/11/2020
REV:	ECO:

SPECIFICATION SHEET

Striem
 3100 Brinkerhoff
 Kansas City, KS 66115
 Tel: 913-222-1500
 Fax: 913-291-0457
 www.striemco.com



Made in the U.S.A

PROPRIETARY AND CONFIDENTIAL

THE INFORMATION CONTAINED IN THIS DRAWING IS THE SOLE PROPERTY OF STRIEM, LLC. ANY REPRODUCTION IN PART OR AS A WHOLE WITHOUT THE WRITTEN PERMISSION OF STRIEM, LLC. IS PROHIBITED.