

**SPECIFICATIONS (OS-1000-SS)**

1. Max flow rate: 314 GPM
2. Liquid capacity: 1000 Gallons (133.7 cu. ft.)
3. Oil capacity: 451 Gallons
4. Solids/sediment capacity: 347 Gallons
5. Unit weight w/std. covers: 1215 lbs.
6. Highway traffic load rated, bolted, gas/water tight composite covers. (16,000 lbs)
7. Maximum operating temperature 140°F continuous.
8. Slick Stick™ Oil Monitoring System (see page 2)

**NOTES**

1. 1" thick high density polyethylene walls.
2. Unit supplied with built-in adapter(s) for up to 3-1/2" of adjustability. Additional riser(s) available for deeper burial depth.
3. For buried applications.
4. Lifting lug set included for easy install.

**ENGINEER SPECIFICATION GUIDE**

Striem oil separator model OS-1000-SS shall be lifetime guaranteed and made in USA of polyethylene with minimum 1" uniform wall thickness. Separator shall be furnished for below grade installation with field adjustable riser system. Separator shall be furnished with an oil level monitoring system. Separator flow rate shall be 314 GPM. Separator oil capacity shall be 451 gallons. Sand capacity shall be 347 gallons. Cover shall provide water/gas-tight seal and have a maximum 16,000 lbs load capacity.

**THIRD PARTY STRUCTURAL ANALYSIS**

The OS-1000-SS has been structurally analyzed in accordance with the requirements of IBC 2012 and ASCE/SEI 7 for direct burial. The maximum burial depth and backfill material are specified in our installation instructions. The structural design has been reviewed and sealed by a professional engineer registered in the state of California. A sealed structural analysis report is available upon request.

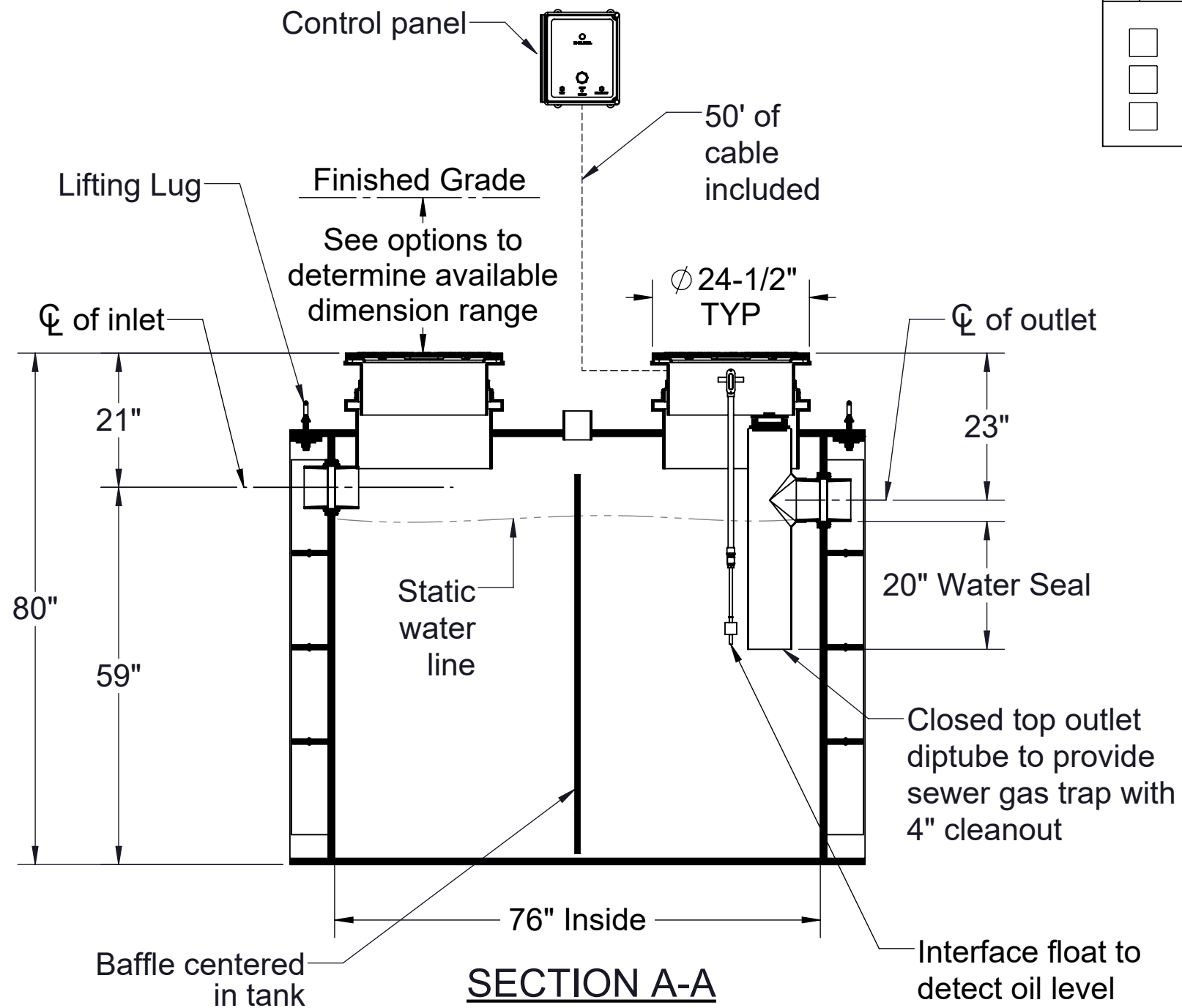
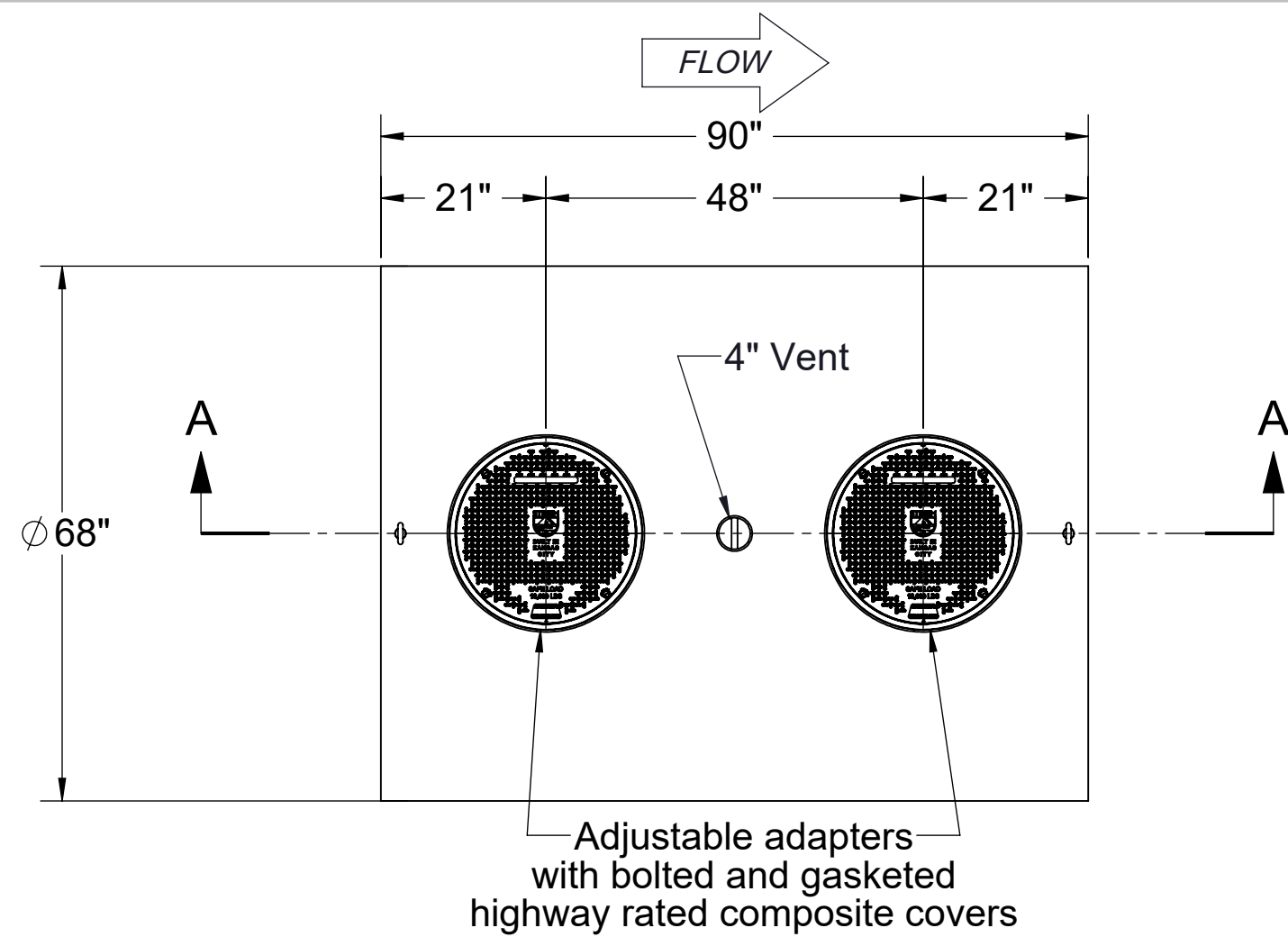
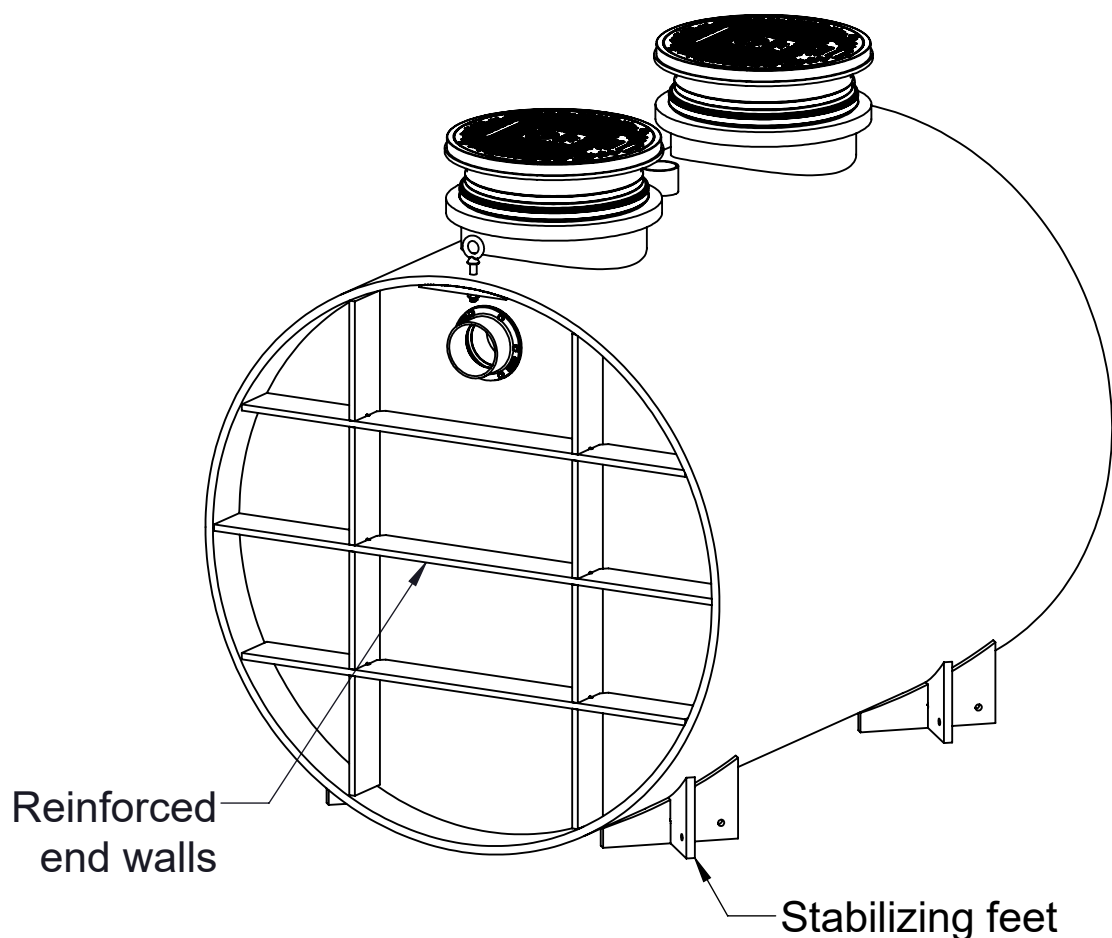

**Directions:** Complete steps 1-3 and submit signed with purchase order.

**1. Choose Connection Types.**

- |                                      |  |
|--------------------------------------|--|
| <b>Inlet / Outlet</b>                | <b>Size</b>  |
| <input type="checkbox"/> Plain End   | <input type="checkbox"/> 4"                            |
| <input type="checkbox"/> Male Thread | <input type="checkbox"/> 6"                            |
|                                      | <input type="checkbox"/> 8" (Only Plain End Available) |
| <b>Vent</b>                          | <b>Size</b>  |
| Plain End                            | <input type="checkbox"/> 2"                            |
|                                      | <input type="checkbox"/> 3"                            |
|                                      | <input type="checkbox"/> 4"                            |

**2. TeleGlide Riser Options.**

- SR24 (2) - >3'-1/2"-22"
- LR24 (2) - >22"-37"
- SR24 (4) - >37"-41"
- SR24 (2) + LR24 (2) - >41"-56"
- LR24 (4) - >56"-70"

**3. Choose Additional Options.**

- C24-HP (2) - H2O Rated Pickable Cast Iron Covers
- CS3 - Clean Sweep Coalescing Media (single)
- HDK-1 - High Water Table Hold Down Kit

Signature of Approval: \_\_\_\_\_

Company: \_\_\_\_\_

Date of Approval: \_\_\_\_\_

Specifying Engineer: \_\_\_\_\_

Engineering Firm: \_\_\_\_\_

PO IS NON-CANCELABLE  
ORDER IS NON-RETURNABLE

|   |                         |                |             |
|---|-------------------------|----------------|-------------|
| <b>MODEL NUMBER:</b> OS-1000-SS   |                         |                |             |
| <b>DESCRIPTION:</b><br>1000 GAL POLYETHYLENE OIL/SAND SEPARATOR WITH SLICK STICK™ OIL LEVEL MONITORING SYSTEM |                         |                |             |
| <b>DWG BY:</b> MJ   | <b>DATE:</b> 06/29/2020 | <b>REV:</b> 02 | <b>ECO:</b> |

**SPECIFICATION SHEET**

**Striem**  
3100 Brinkerhoff  
Kansas City, KS 66115  
Tel: 913-222-1500  
Fax: 913-291-0457  
www.striemco.com



Made in the U.S.A

THE INFORMATION CONTAINED IN THIS DRAWING IS THE SOLE PROPERTY OF STRIEM, LLC. ANY REPRODUCTION IN PART OR AS A WHOLE WITHOUT THE WRITTEN PERMISSION OF STRIEM, LLC. IS PROHIBITED.

**SPECIFICATIONS**

1. UL Listed
2. Provides warning of high oil level conditions with interface float.
3. Single phase, 120 volt, 60 hertz power required.
4. NEMA 4X fiberglass, corrosion resistant, weatherproof enclosure suitable for outdoor use and damp environments.
5. Audible Alarm Buzzer, 95dB pulsing horn with no timeout.
6. High Oil Light, indicates oil has accumulated below the oil interface float or the tank liquid level is below the High Oil Interface Float.
7. Power On light inside enclosure. Visible from the outside.
8. Green light indicates the power is on.
9. Horn off button that silences the audible alarm when pressed.
10. Test button that when pressed will test the system electronics.
11. Locking clasp on door.
12. Alarm bell stays on until reset. Light stays on until reset, even if level goes down.
13. Unit comes supplied with extra dry contact for connection to a building alarm system.

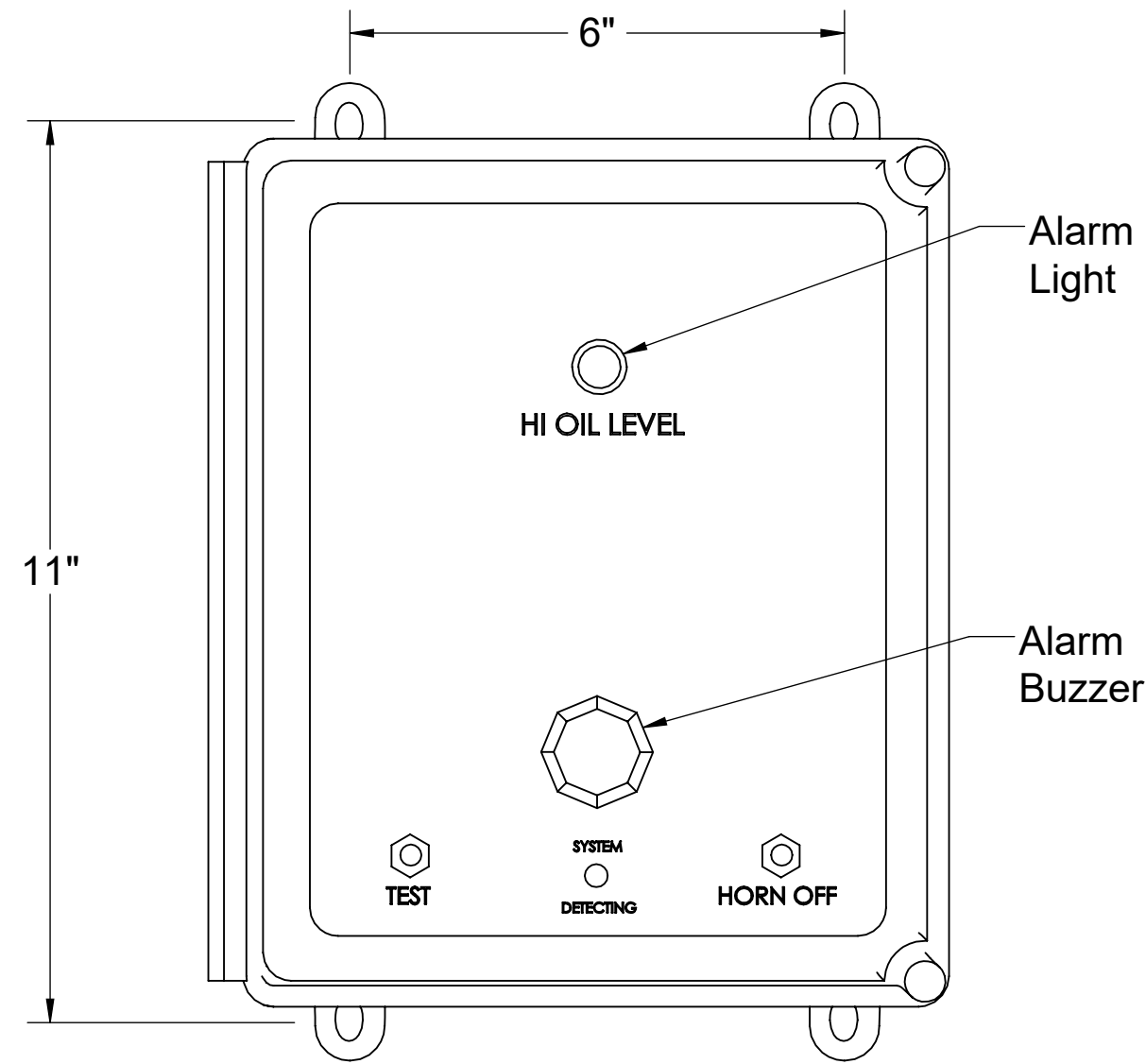

**FRONT VIEW**

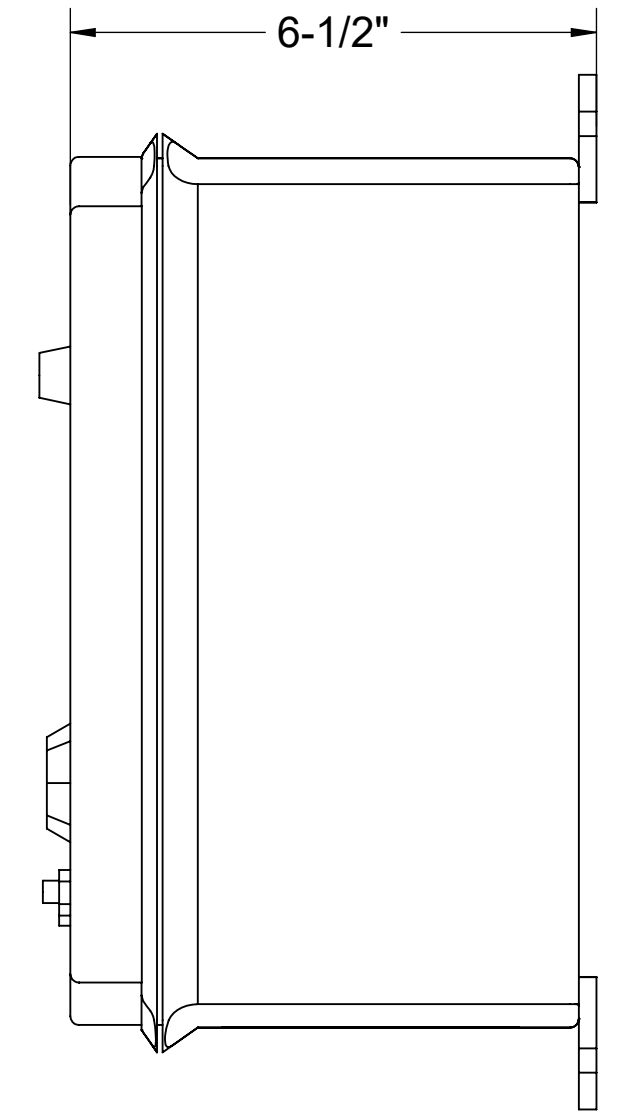

**LEFT VIEW**

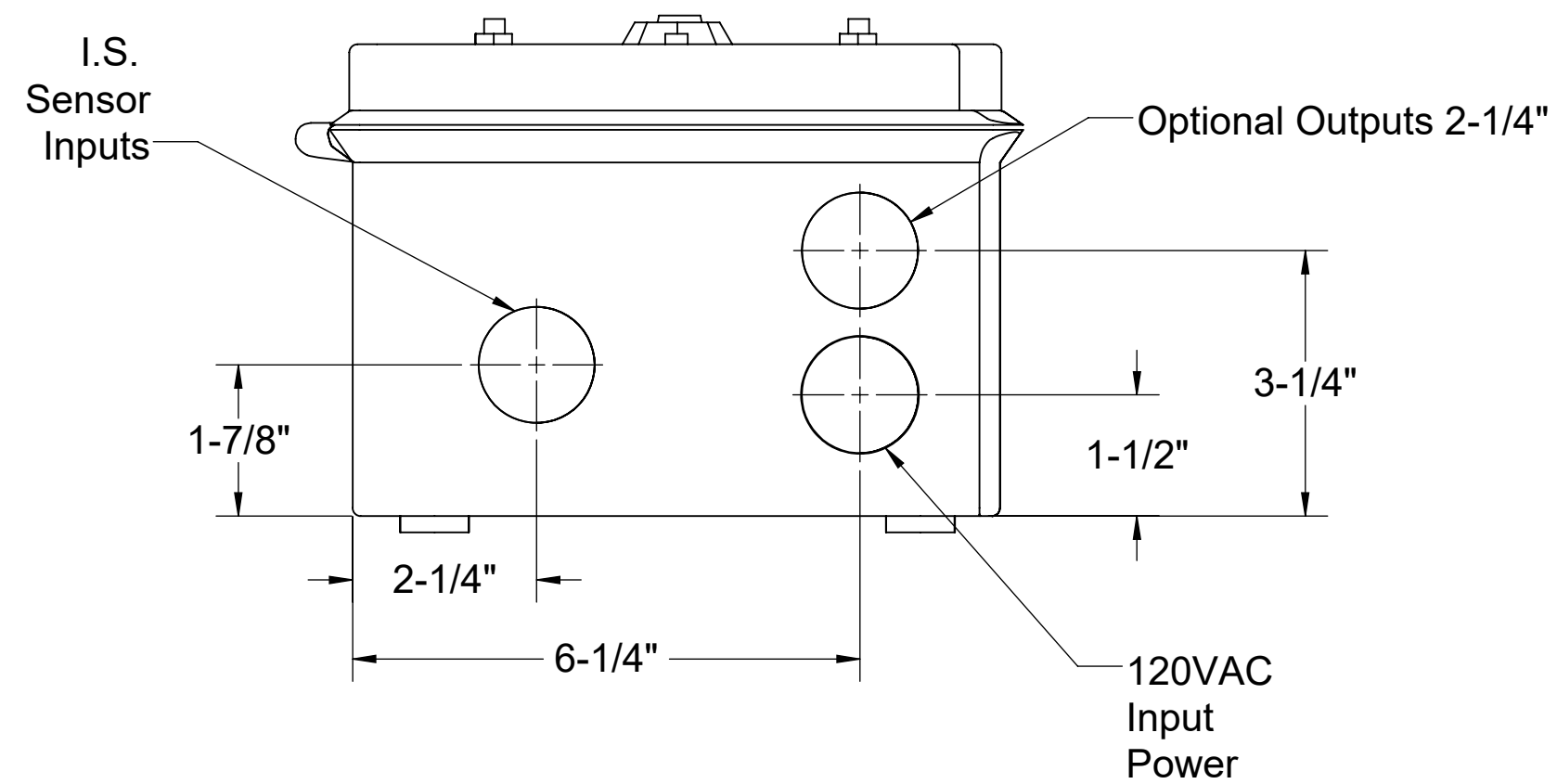
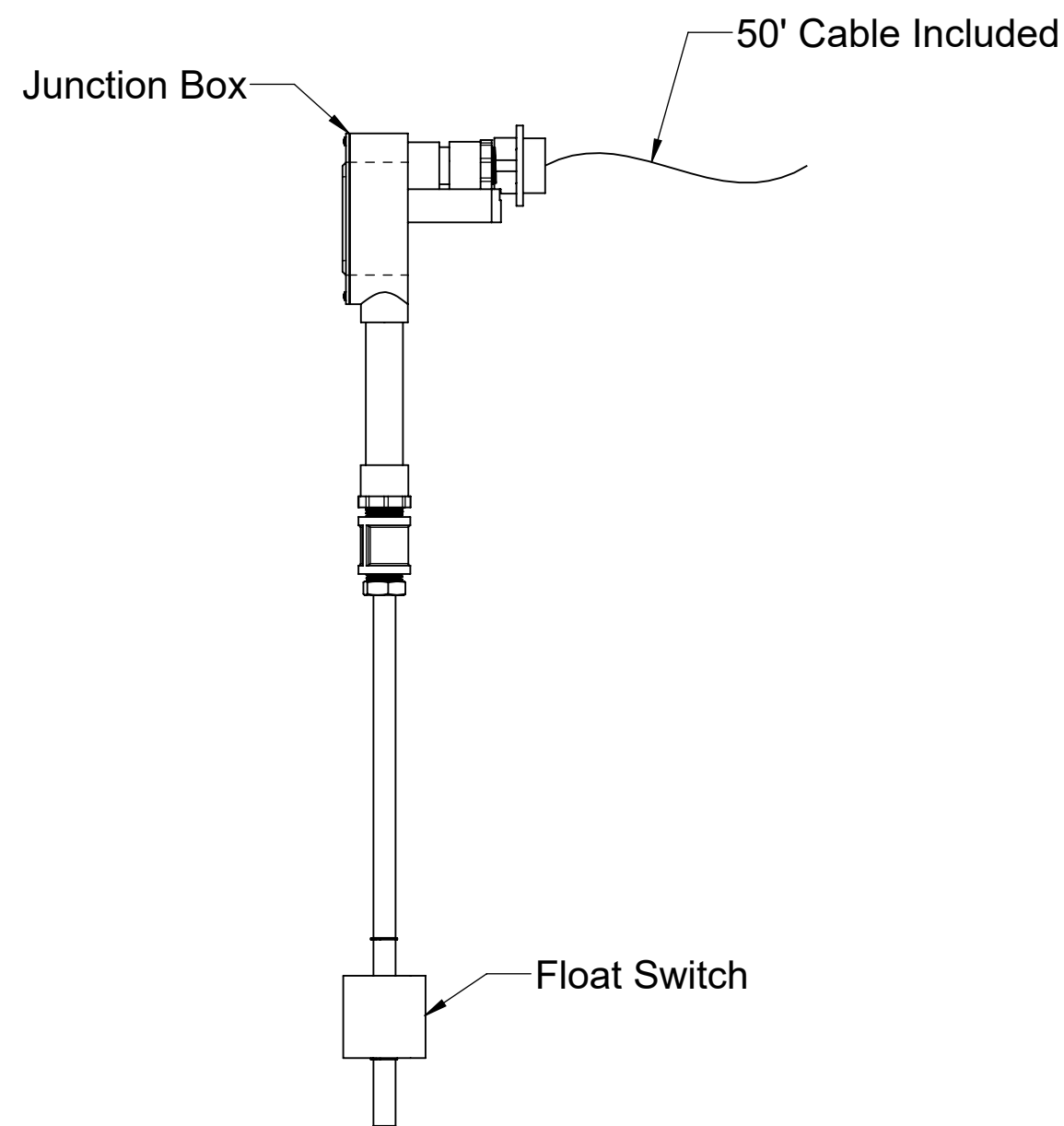

**BOTTOM VIEW**

|   |                         |                            |             |   |  |
|---|-------------------------|----------------------------|-------------|---|--|
| <b>MODEL NUMBER:</b> 8056-001-01  |                         | <b>SPECIFICATION SHEET</b> |             |   |  |
| <b>DESCRIPTION:</b><br>SLICK STICK™ OIL LEVEL MONITORING SYSTEM FOR OS-50, OS-75, OS-100, OS-750, OS-1000 & OS-1500 |                         |                            |             |   |  |
| <b>DWG BY:</b> MJ   | <b>DATE:</b> 06/29/2020 | <b>REV:</b> 02             | <b>ECO:</b> | <b>Striem</b><br>3100 Brinkerhoff<br>Kansas City, KS 66115<br>Tel: 913-222-1500<br>Fax: 913-291-0457<br>www.striemco.com<br><br>Made in the U.S.A |  |

PROPRIETARY AND CONFIDENTIAL

THE INFORMATION CONTAINED IN THIS DRAWING IS THE SOLE PROPERTY OF STRIEM, LLC. ANY REPRODUCTION IN PART OR AS A WHOLE WITHOUT THE WRITTEN PERMISSION OF STRIEM, LLC. IS PROHIBITED.

**Installation Guidelines:**

1. The Slick Stick™ interface float and alarm panel will ship separately from the tank.
2. Install the 1/2" FPT brass coupling to the end of the Slick Stick™ interface float. Thread the 1/2" MPT x socket PVC fitting into the 1/2" FPT brass coupling.
3. If the tank is to be installed above grade, or without any adjustment to the adapter, install a length of 1/2" sch. 40 PVC pipe between the bottom of the junction box and the top of the 1/2" MPT x socket PVC fitting. Choose the length from Table 1 that corresponds with the unit, and oil capacity to be monitored.
4. If the tank is buried, and the adapter will be adjusted upward and/or risers will be used, add the total upward extension dimension to the length determined from Table 1 to determine total length of 1/2" PVC pipe length. For example, assume an OS-75 is being installed below grade and requires 26" of riser extension. Assume you want the control panel to alarm when the oil capacity reaches 70% of the total oil capacity. The length of the 1/2" PVC pipe extension should be 26" (riser depth) + 10" (from Table 1) = 36".
5. Run interface float wiring through 1/2" PVC pipe and into the bottom of the junction box inside the adapter. Connect wiring to alarm panel (see wire diagram).

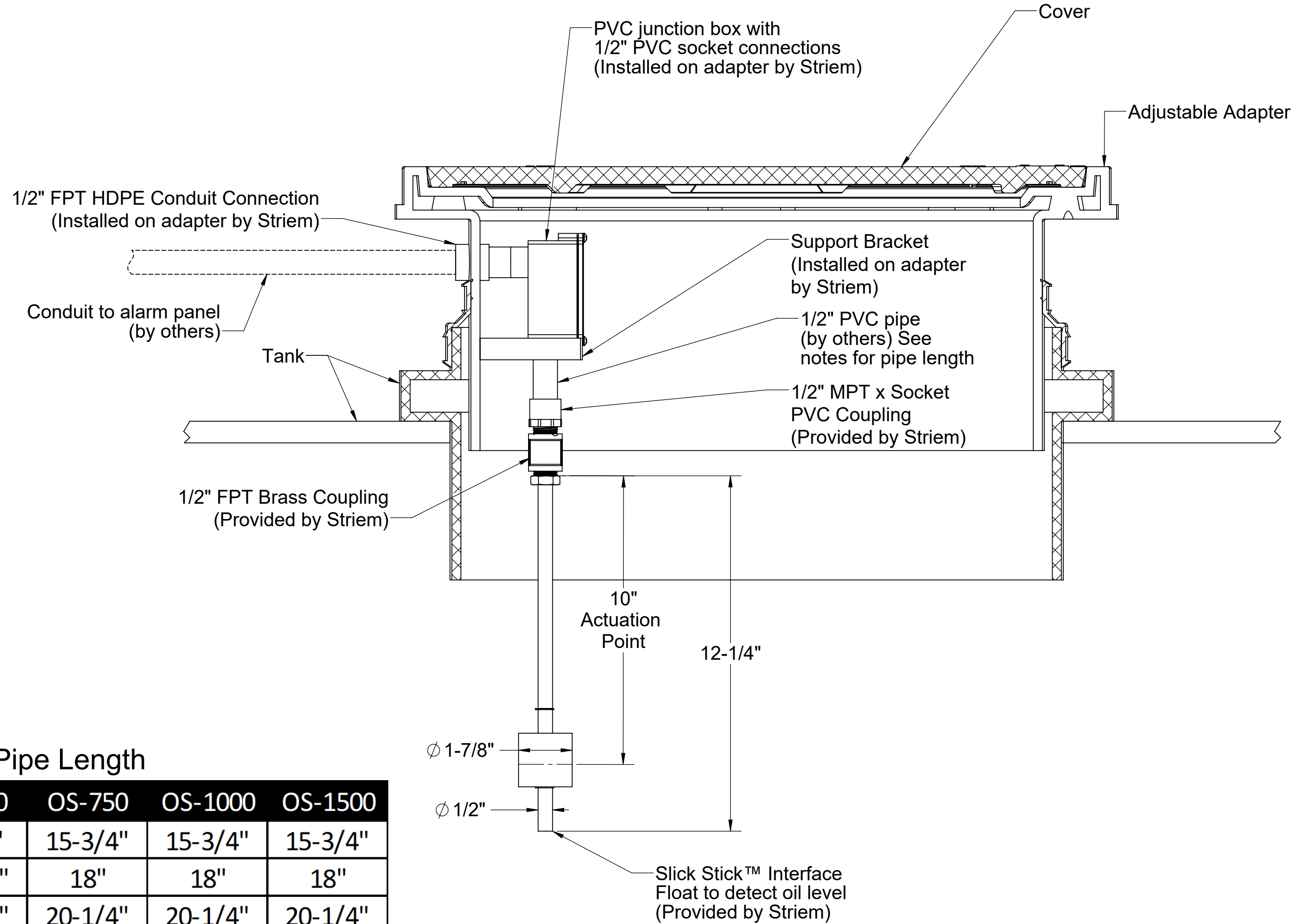

**Table 1: 1/2" PVC Pipe Length**

| Oil Capacity | OS-50  | OS-75   | OS-100  | OS-750  | OS-1000 | OS-1500 |
|--------------|--------|---------|---------|---------|---------|---------|
| 50%          | 1-1/2" | 6-5/8"  | 9-5/8"  | 15-3/4" | 15-3/4" | 15-3/4" |
| 60%          | 2-3/8" | 8-1/4"  | 11-1/2" | 18"     | 18"     | 18"     |
| 70%          | 3-3/8" | 10"     | 13-1/4" | 20-1/4" | 20-1/4" | 20-1/4" |
| 80%          | 4-3/8" | 12"     | 15"     | 22-1/2" | 22-1/2" | 22-1/2" |
| 90%          | 5-1/2" | 13-7/8" | 18-3/4" | 24-1/2" | 24-1/2" | 24-1/2" |

PROPRIETARY AND CONFIDENTIAL

THE INFORMATION CONTAINED IN THIS DRAWING IS THE SOLE PROPERTY OF STRIEM, LLC. ANY REPRODUCTION IN PART OR AS A WHOLE WITHOUT THE WRITTEN PERMISSION OF STRIEM, LLC. IS PROHIBITED.

**DESCRIPTION:**

**SLICK STICK™  
INTERFACE FLOAT  
INSTALLATION GUIDELINES**

**DWG BY: MJ    DATE: 06/29/2020    REV: 02    ECO:**

**Striem**  
3100 Brinkerhoff  
Kansas City, KS 66115  
Tel: 913-222-1500  
Fax: 913-291-0457  
www.striemco.com

**Made in the U.S.A**

