

SPECIFICATIONS

1. 2" Plain inlet/No outlet, 3" Plain vents.
2. Oil capacity: 57 Gallons (7.6 cu ft).
3. Unit weight w/std. covers: 68 lbs.
4. Maximum operating temperature: 140°F continuous.
5. Pedestrian rated covers: 2,000 lb. capacity.

NOTES

1. Seamless polyethylene tank.
2. Unit supplied with built-in adapter(s) for up to 3 1/2" of adjustability. Additional riser(s) available for deeper burial depth.
3. Cover placement allows full access to tank for proper maintenance.
4. Narrow footprint allows clearance through doorways and down stairwells.
5. For on the-floor or buried applications.

ENGINEER SPECIFICATION GUIDE

Striem Oil Reserve™ oil collection tank model OCT-50 shall be lifetime guaranteed and made in USA of seamless, rotationally-molded Polyethylene with minimum 3/8" uniform wall thickness. Separator shall be furnished for above or below grade installation, with field adjustable riser system, 2" Plain inlet line and 3" Plain vent connections. Oil collection tank shall have an oil storage capacity of 57 gallons. Cover shall provide water/gas-tight seal and have maximum 2,000 lbs load capacity.

THIRD PARTY STRUCTURAL ANALYSIS

The OCT-50 has been structurally analyzed in accordance with the requirements of IBC 2012 and ASCE/SEI 7 for direct burial. The maximum burial depth and backfill material are specified in our installation instructions. The structural design has been reviewed and sealed by a professional engineer registered in the state of California. A sealed structural analysis report is available upon request.

OPTIONS

- 2M** - 2" Male Thread Inlet
- 3P** - 3" Plain End SCH.40 Inlet
- 3M** - 3" Male Thread Inlet
- 4P** - 4" Plain End SCH.40 Inlet
- 4M** - 4" Male Thread Inlet
- C24-H** - Highway Rated Composite Cover
- C24-HP** - H20 Rated Pickable Cast Iron Cover
- CC24** - Integral Membrane Clamping Collar Kit
- AK1** - High Water Anchor Kit
- AVA-3** - Single Level Monitoring Package*
- AVA-4** - Multi-Level Monitoring Package*

*Monitoring packages will raise covers by 2-1/2".

TeleGlide RISER OPTIONS

- SR24** - >3 1/2"-22"
- LR24** - >22"-37"

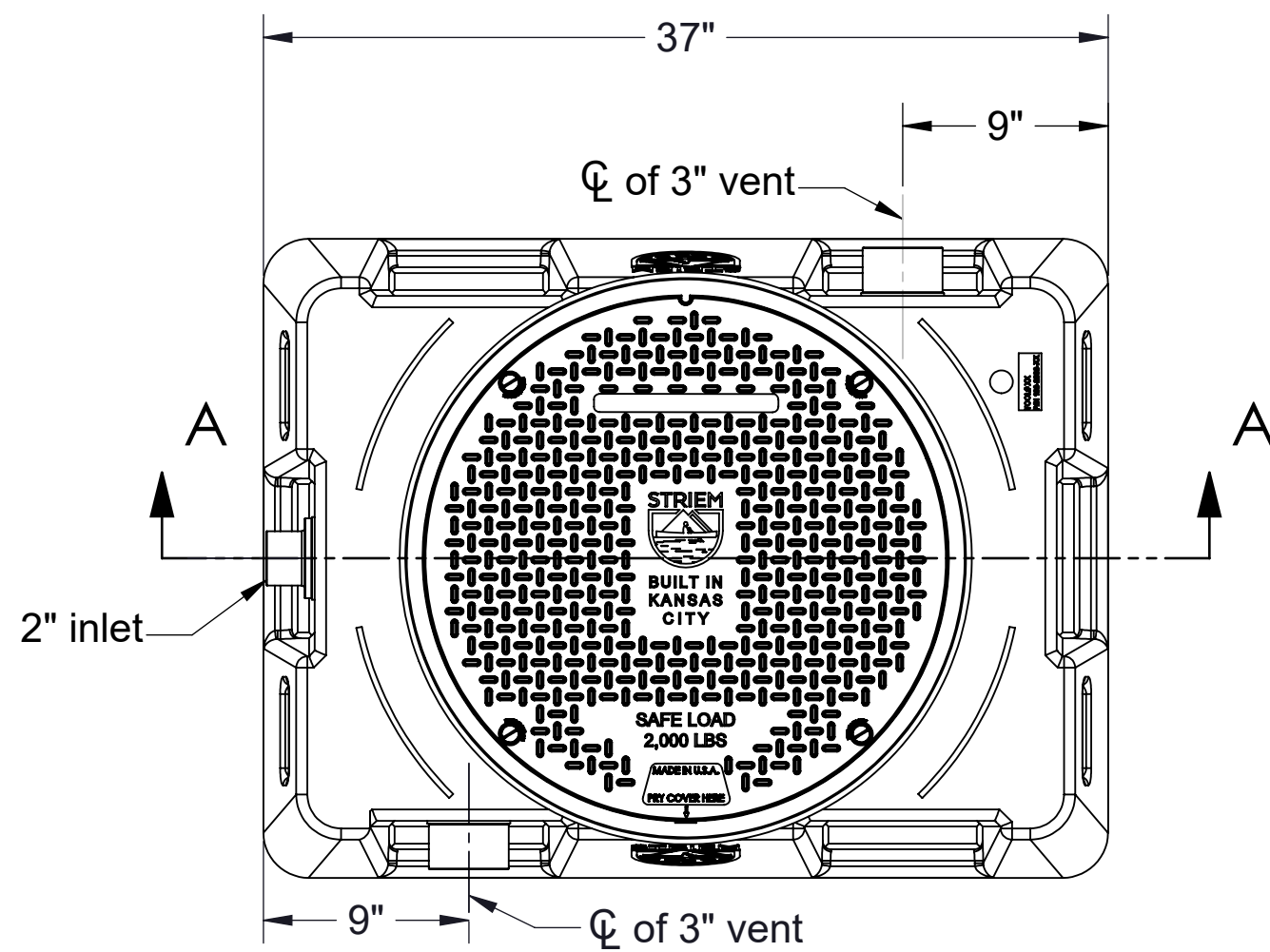

TOP VIEW

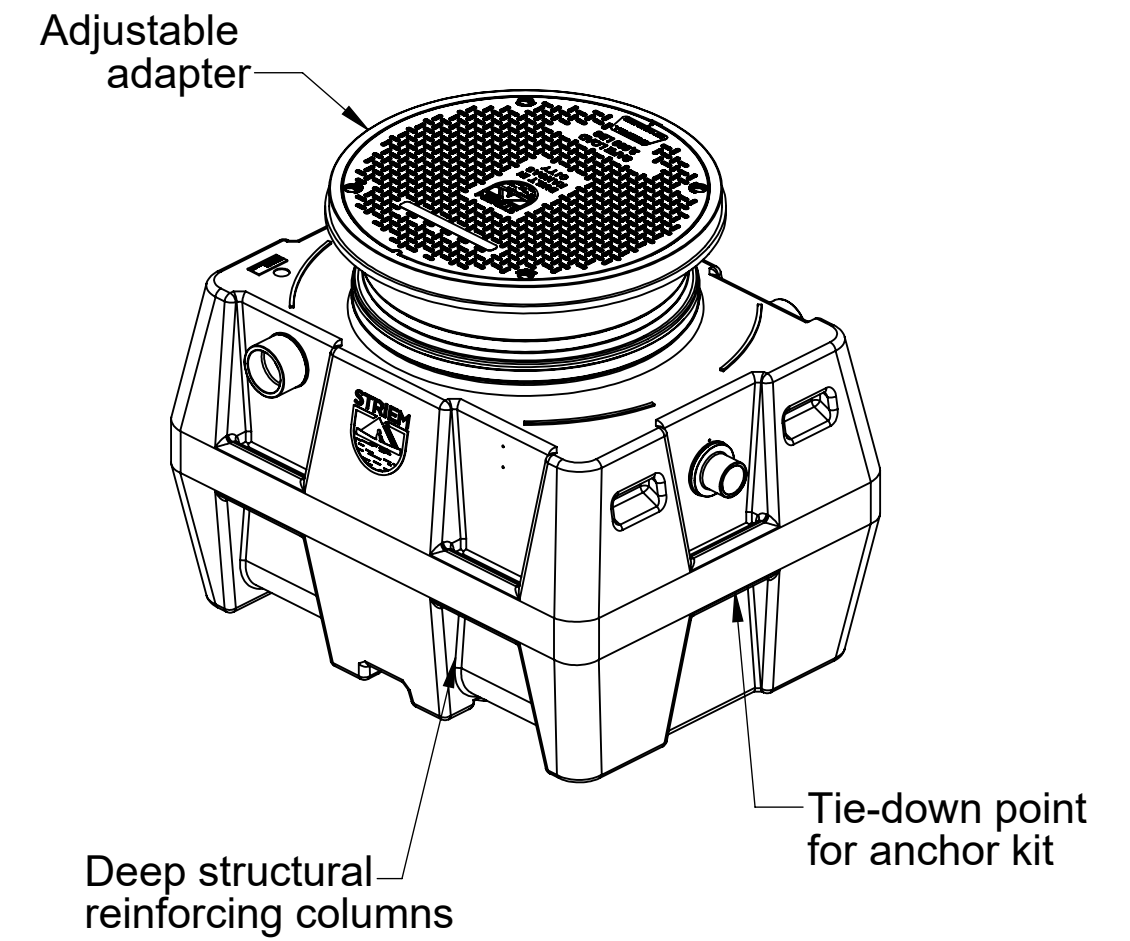

ISOMETRIC VIEW

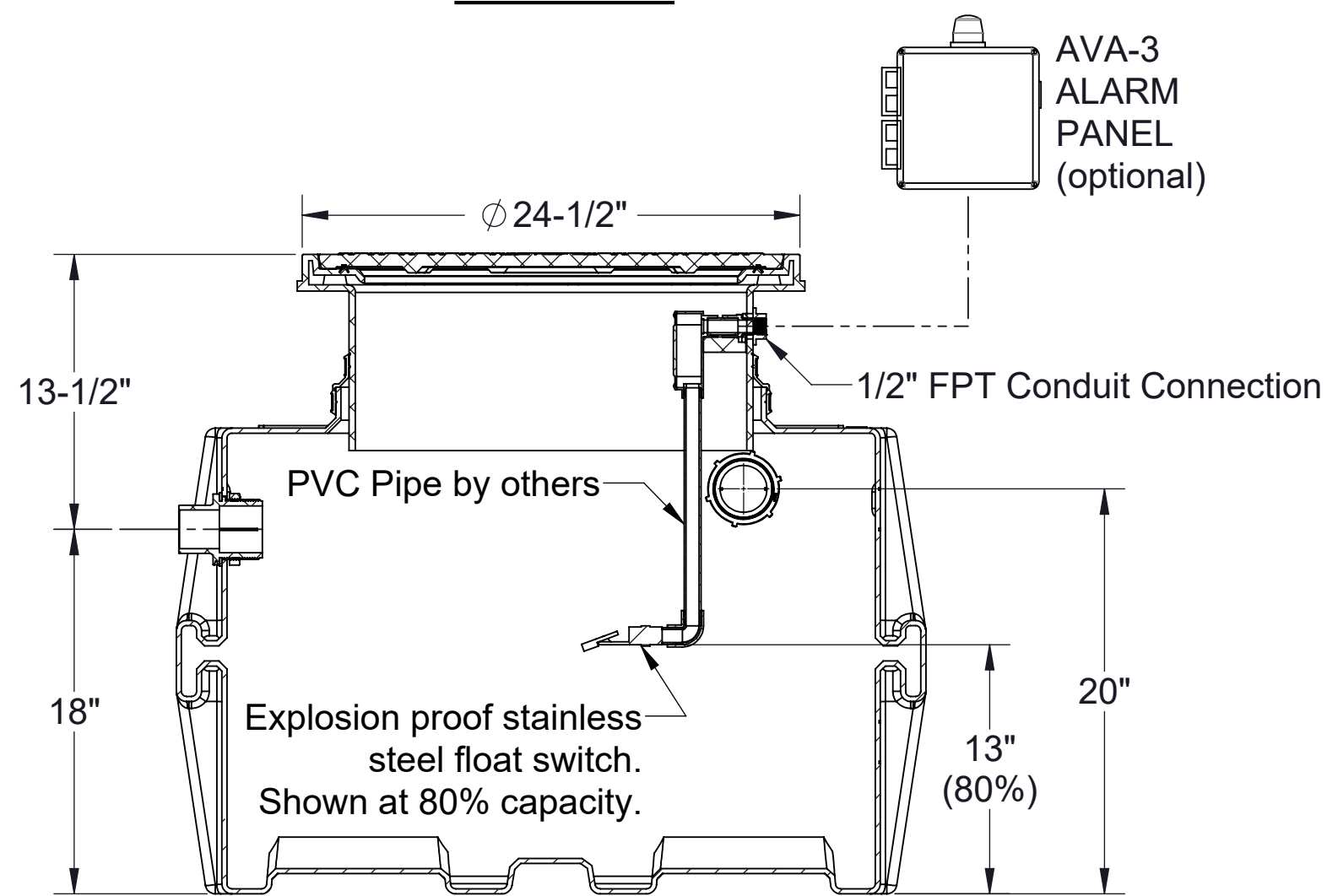

SECTION "A-A"

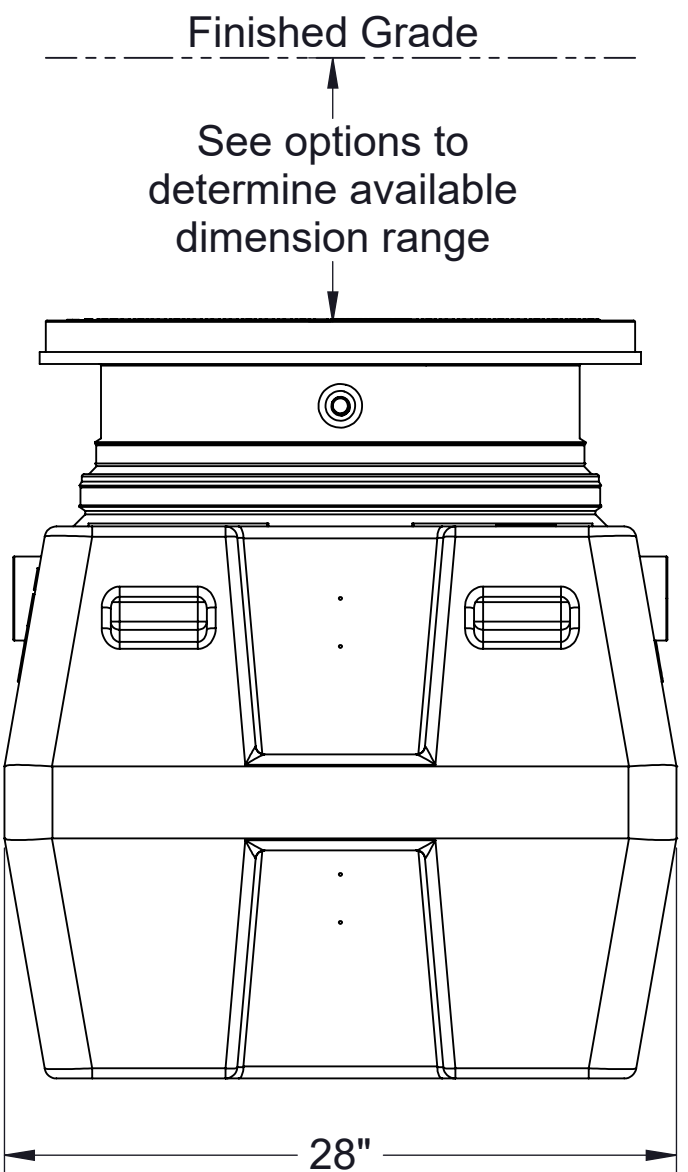

END VIEW

MODEL NUMBER: OCT-50	
DESCRIPTION: 52 GAL POLYETHYLENE OIL COLLECTION TANK	
DWG BY: MJ	DATE: 03/03/20
REV: 02	ECO:

SPECIFICATION SHEET

Striem
3100 Brinkerhoff
Kansas City, KS 66115
Tel: 913-222-1500
Fax: 913-291-0457
www.striemco.com

Made in the U.S.A

PROPRIETARY AND CONFIDENTIAL

THE INFORMATION CONTAINED IN THIS DRAWING IS THE SOLE PROPERTY OF STRIEM, LLC. ANY REPRODUCTION IN PART OR AS A WHOLE WITHOUT THE WRITTEN PERMISSION OF STRIEM, LLC. IS PROHIBITED.