

SPECIFICATIONS

1. 2" Plain End inlet, 3" Plain End vents, C24-M cover standard.
2. Oil capacity: 57 Gallons (7.6 cu ft).
3. Unit weight w/ standard cover: 93 lbs.; w/ cast iron cover: 153 lbs.
4. Maximum operating temperature: 140 °F continuous.

NOTES

1. For gravity drainage applications only.
2. Do not use for pressure applications.
3. Capped auxiliary vent provided to allow flexibility with vent piping and design. Provided cap can be moved to unused vent location, or discarded if two chamber vents are required per local code.
4. Narrow footprint allows clearance through doorways and down stairs.
5. Cover placement allows full access to tank for proper maintenance.
6. Maximum burial depth: 39" (36" w/ monitoring) from standard cover height.

ENGINEER SPECIFICATION GUIDE

Striem oil collection tank model OCT-50 shall be lifetime guaranteed and made in the USA. Tank shall be constructed of polyethylene. Tank shall be manufactured for above- or below-grade installation. Field-adjustable riser system is available as an option to bring manhole cover to grade. Tank oil collection capacity shall be 57 gallons. Cover shall provide water/gas-tight seal and have a maximum 2,000 lbs. load capacity.

OPTIONS	
Connection Options (Plain End Only)	
Inlet	
<input type="checkbox"/> 2"	
<input type="checkbox"/> 3"	
<input type="checkbox"/> 4"	
Riser Options	
From Factory:	Up to 5" (Up to 2" w/ monitoring)
<input type="checkbox"/>	Up to 24" (21" w/ monitoring): SR24
<input type="checkbox"/>	Up to 39" (36" w/ monitoring): LR24
Additional Options	
<input type="checkbox"/>	HDK-2: High Water Table Hold Down Kit
<input type="checkbox"/>	C24-H: Highway Rated Composite Cover
<input type="checkbox"/>	C24-HP: H20 Rated Pickable Cast Iron Cover
<input type="checkbox"/>	AVA-3: Single-Level Monitoring Package

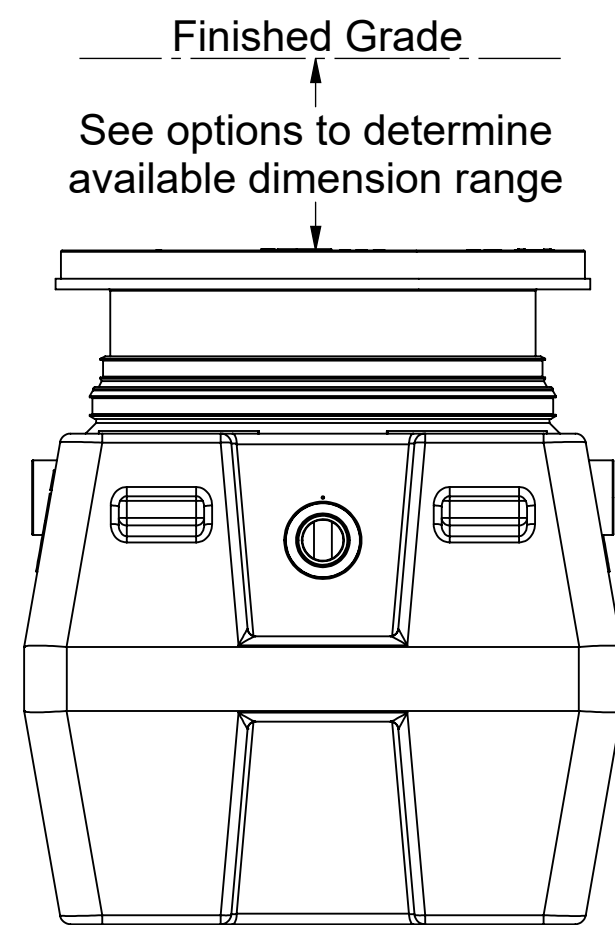
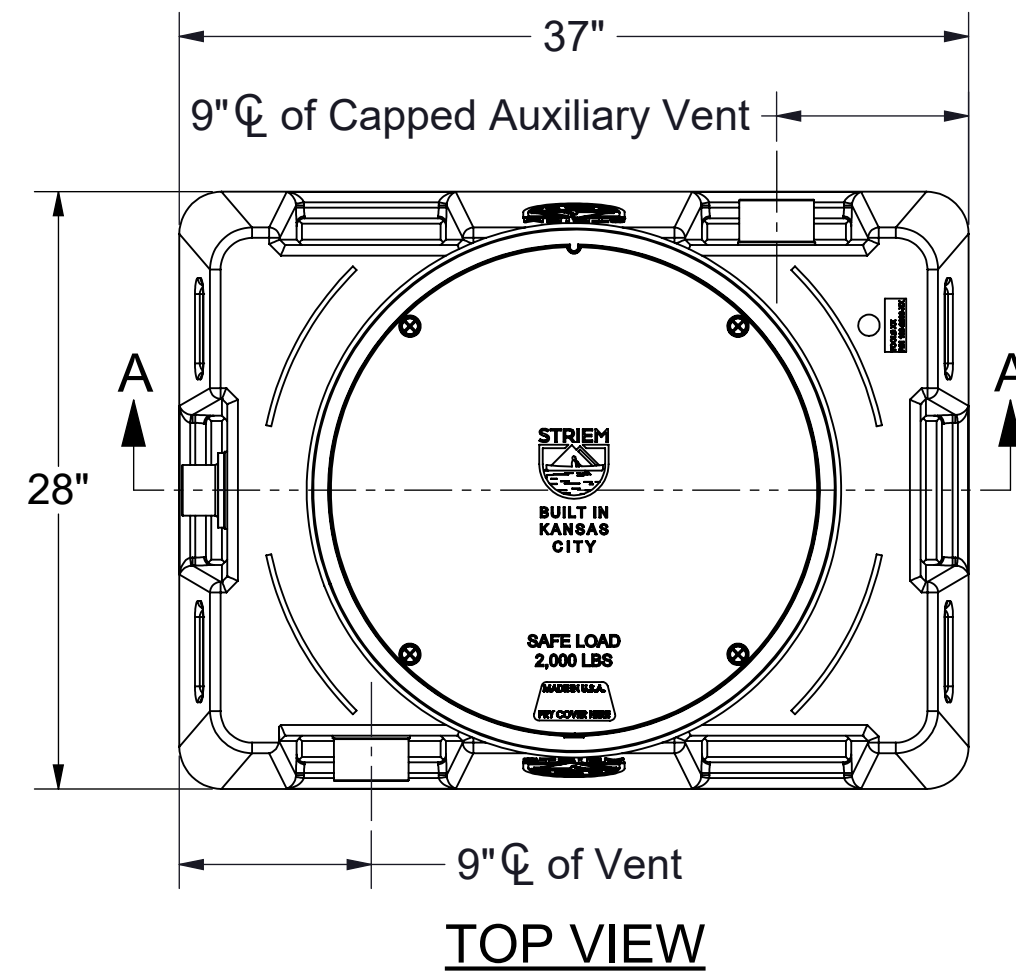

END VIEW

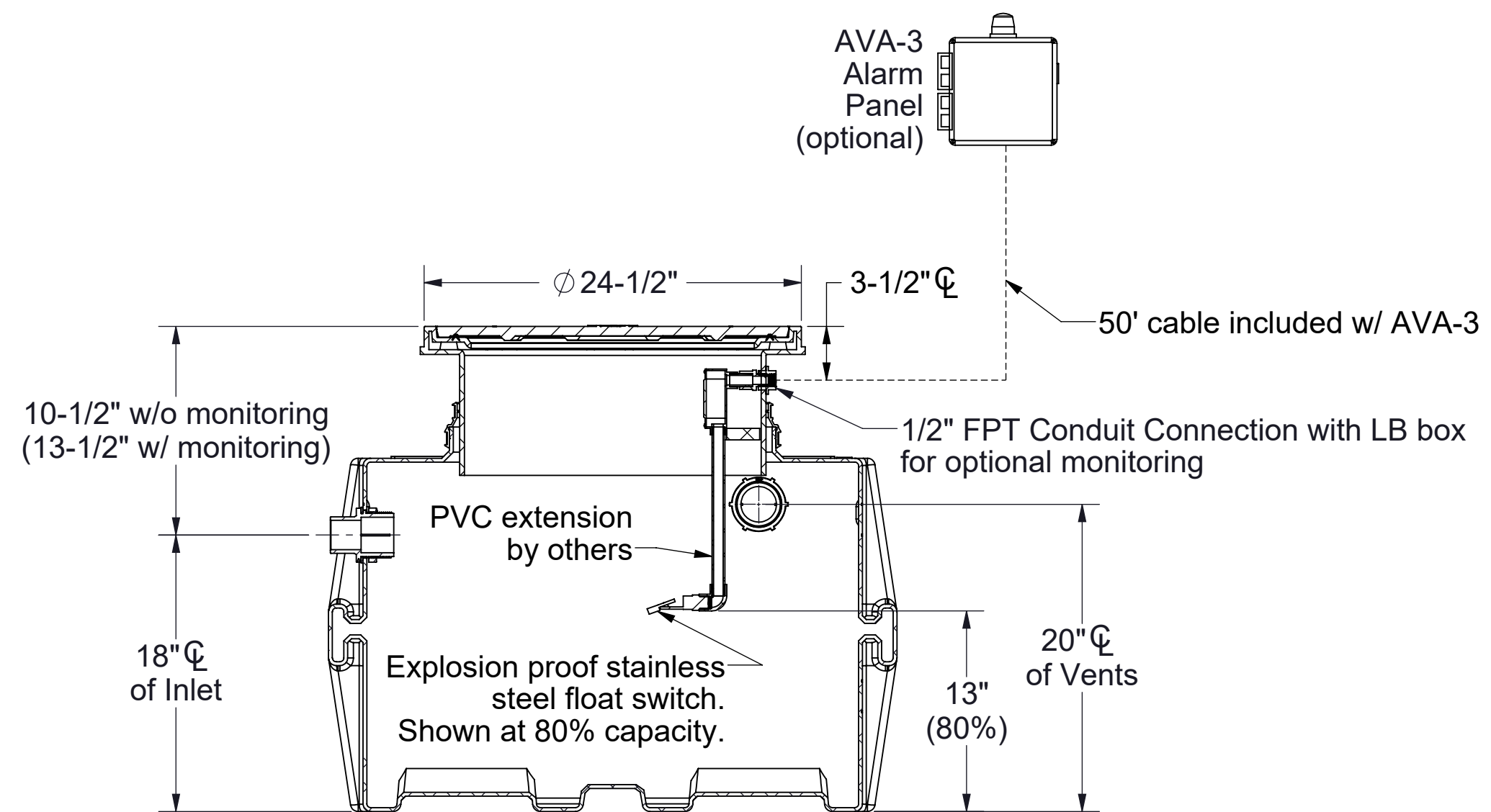

SECTION A-A

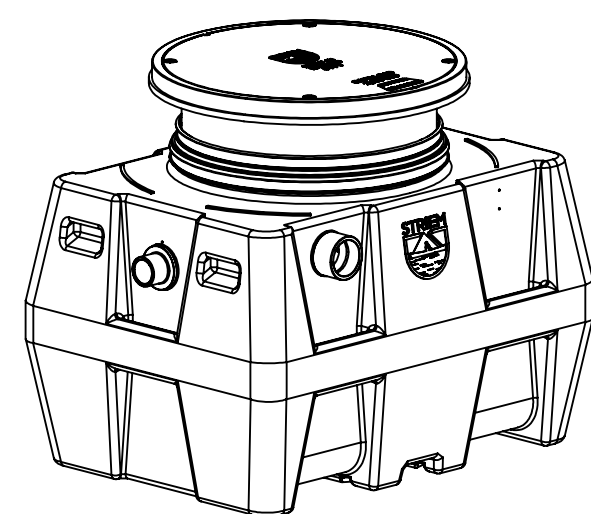

PROPRIETARY AND CONFIDENTIAL
 THE INFORMATION CONTAINED IN THIS DRAWING IS THE SOLE PROPERTY OF STRIEM, LLC.
 ANY REPRODUCTION IN PART OR AS A WHOLE WITHOUT THE WRITTEN PERMISSION OF STRIEM, LLC. IS PROHIBITED.

MODEL NUMBER:	OCT-50
DESCRIPTION:	57 GALLON POLYETHYLENE OIL COLLECTION TANK
DWG BY:	ENG
DATE:	1/14/2025
REV:	1

SPECIFICATION SHEET

Striem
 Kansas City, KS
 Tel: 913-222-1500
 orders@striemco.com
 www.striemco.com

Made in the U.S.A

