

**SPECIFICATIONS**

1. 4" Plain End inlet/outlet, 3" Plain End vent, C24-M cover standard.
2. Certified max flow rate: 50 GPM.
3. Liquid capacity: 57 Gallons (7.6 cu. ft.).
4. Oil capacity: 14.25 Gallons.
5. Solids capacity: 7 Gallons.
6. Unit weight w/ standard cover: 93 lbs.; w/ cast iron cover: 153 lbs.
7. Maximum operating temperature 140°F continuous.
8. Slick Stick Oil Level Monitoring System (see page 2).

**NOTES**

1. Engineered inlet diffuser efficiently separates oil from water.
2. For gravity drainage applications only.
3. Do not use for pressure applications.
4. Cover placement allows full access to tank for proper maintenance.

**ENGINEER SPECIFICATION GUIDE**

Striem high efficiency oil/water separator model OS-50-SS shall be lifetime guaranteed and made in the USA. Separator shall be certified to IAPMO IGC 325 and carry a UPC listing. Separator shall be constructed of polyethylene. Separator shall be manufactured for above- or below-grade installation. Field-adjustable riser system is available as an option to bring manhole cover to grade. Separator flow rate shall be 50 GPM. Separator liquid holding capacity shall be 57 gallons and oil capacity shall be 14.25 gallons. Solids capacity shall be 7 gallons. Cover shall provide water/gas-tight seal and have a maximum 2,000 lbs. load capacity.

**IAPMO IGC 325 CERTIFICATION**

The OS-50-SS has been third party certified by IAPMO to the IGC 325 standard. The OS-50-SS achieved an average 98% efficiency rating at 50 GPM up to the maximum oil capacity of 14.25 gallons. The structural design has been approved and stamped by a licensed structural engineer for direct burial in accordance with Striem's installation instructions.

**OPTIONS**

**Riser Options**

**From Factory:** Up to 2"

- Up to 21": **SR24**
- Up to 36": **LR24**

**Additional Options**

- HDK-2:** High Water Table Hold Down Kit
- C24-H:** Highway Rated Bolted Composite Cover
- C24-HP:** H20 Rated Pickable Cast Iron Cover

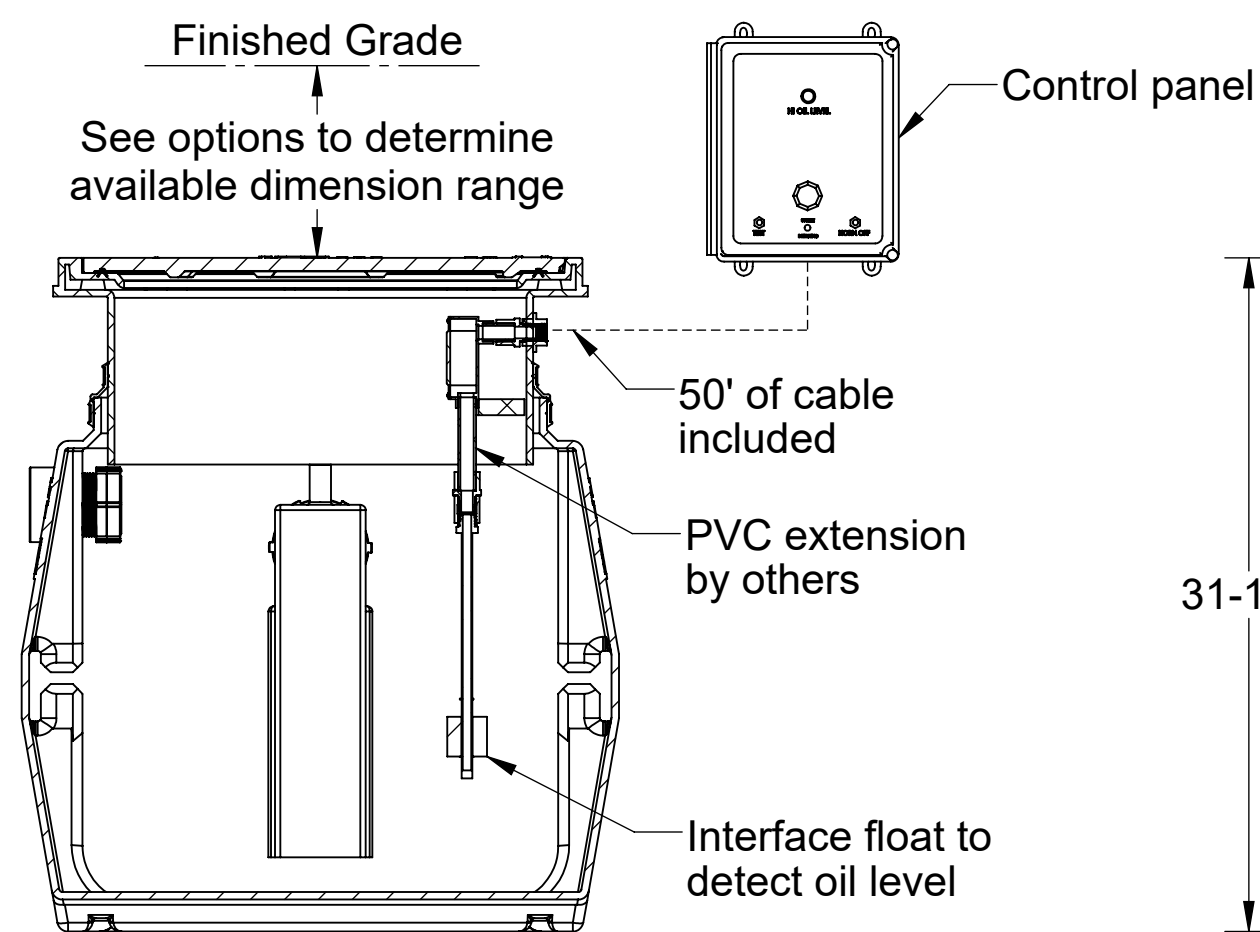
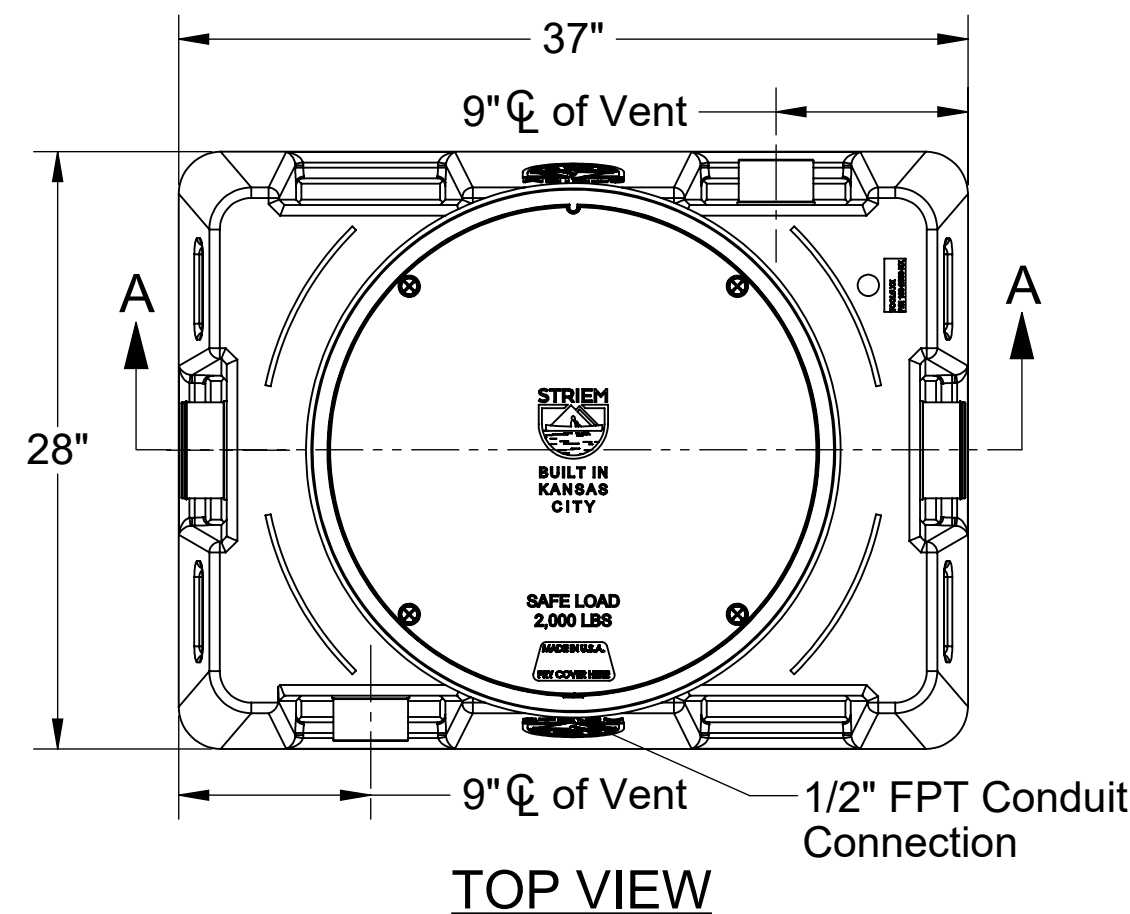

**SECTION B-B**

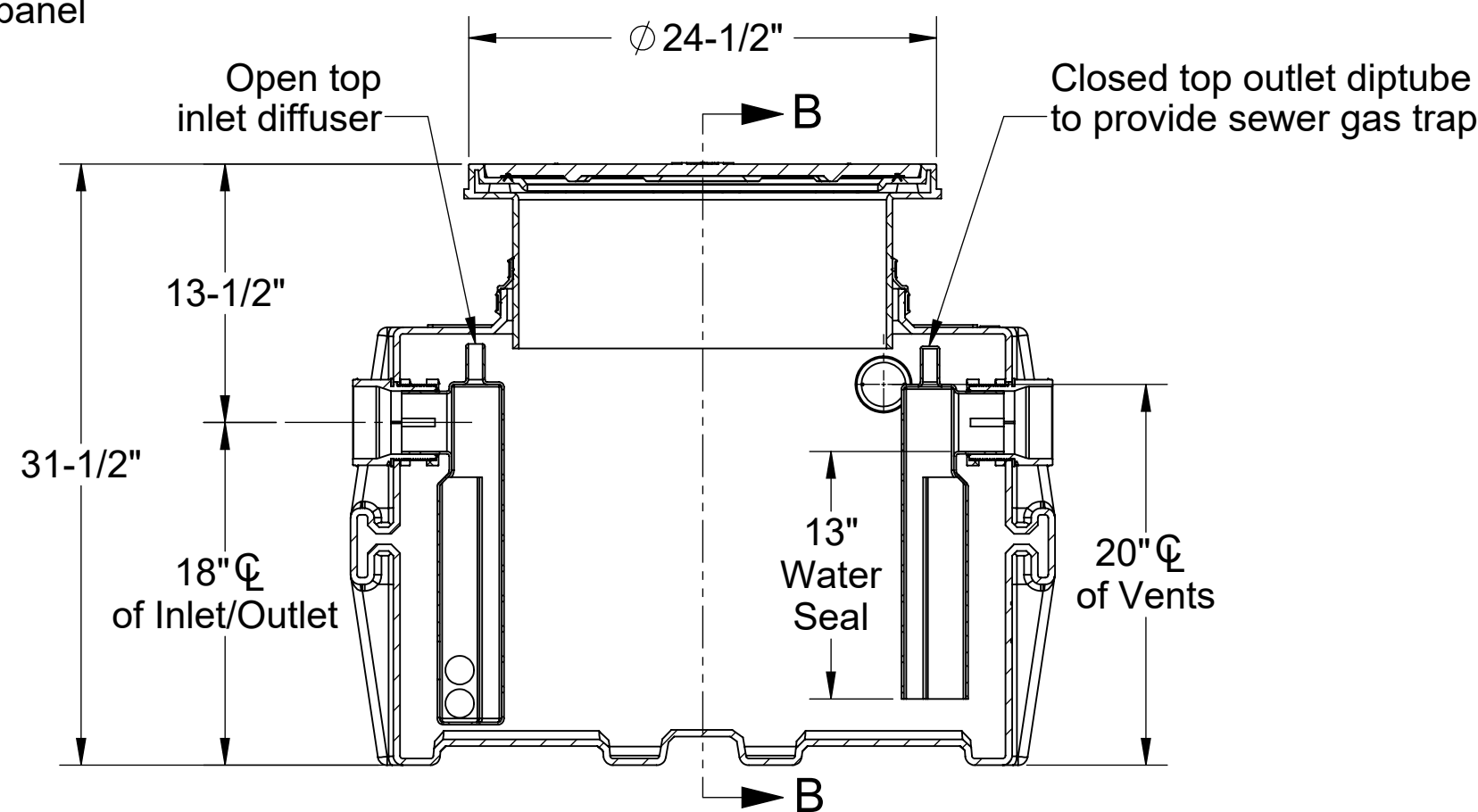

**SECTION A-A**

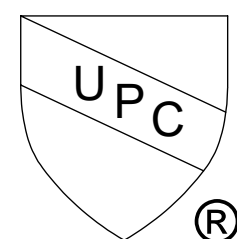
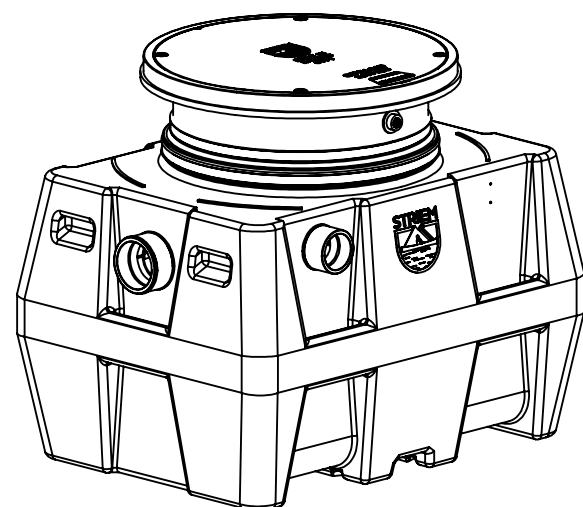

**PROPRIETARY AND CONFIDENTIAL**  
THE INFORMATION CONTAINED IN THIS DRAWING IS THE SOLE PROPERTY OF STRIEM, LLC. ANY REPRODUCTION IN PART OR AS A WHOLE WITHOUT THE WRITTEN PERMISSION OF STRIEM, LLC. IS PROHIBITED.

**MODEL NUMBER:** OS-50-SS

**DESCRIPTION:**  
50 GPM POLYETHYLENE  
HIGH EFFICIENCY OIL/WATER SEPARATOR  
WITH SLICK STICK™ OIL LEVEL MONITORING SYSTEM

**DWG BY:** ENG    **DATE:** 1/8/2024    **REV:** 1

**SPECIFICATION SHEET**

Striem  
Kansas City, KS  
Tel: 913-222-1500  
orders@striemco.com  
www.striemco.com

Made in the U.S.A



**SPECIFICATIONS**

1. UL Listed
2. Provides warning of high oil level conditions with interface float.
3. Single phase, 120 volt, 60 hertz power required.
4. NEMA 4X fiberglass, corrosion resistant, weatherproof enclosure suitable for outdoor use and damp environments.
5. Audible Alarm Buzzer, 95dB pulsing horn with no timeout.
6. High Oil Light, indicates oil has accumulated below the oil interface float or the tank liquid level is below the High Oil Interface Float.
7. Power On light inside enclosure. Visible from the outside. Green light indicates the power is on.
8. Horn off button that silences the audible alarm when pressed.
9. Test button that when pressed will test the system electronics.
10. Locking clasp on door.
11. Alarm bell stays on until reset. Light stays on until reset, even if level goes down.
12. Unit comes supplied with extra dry contact for connection to a building alarm system.

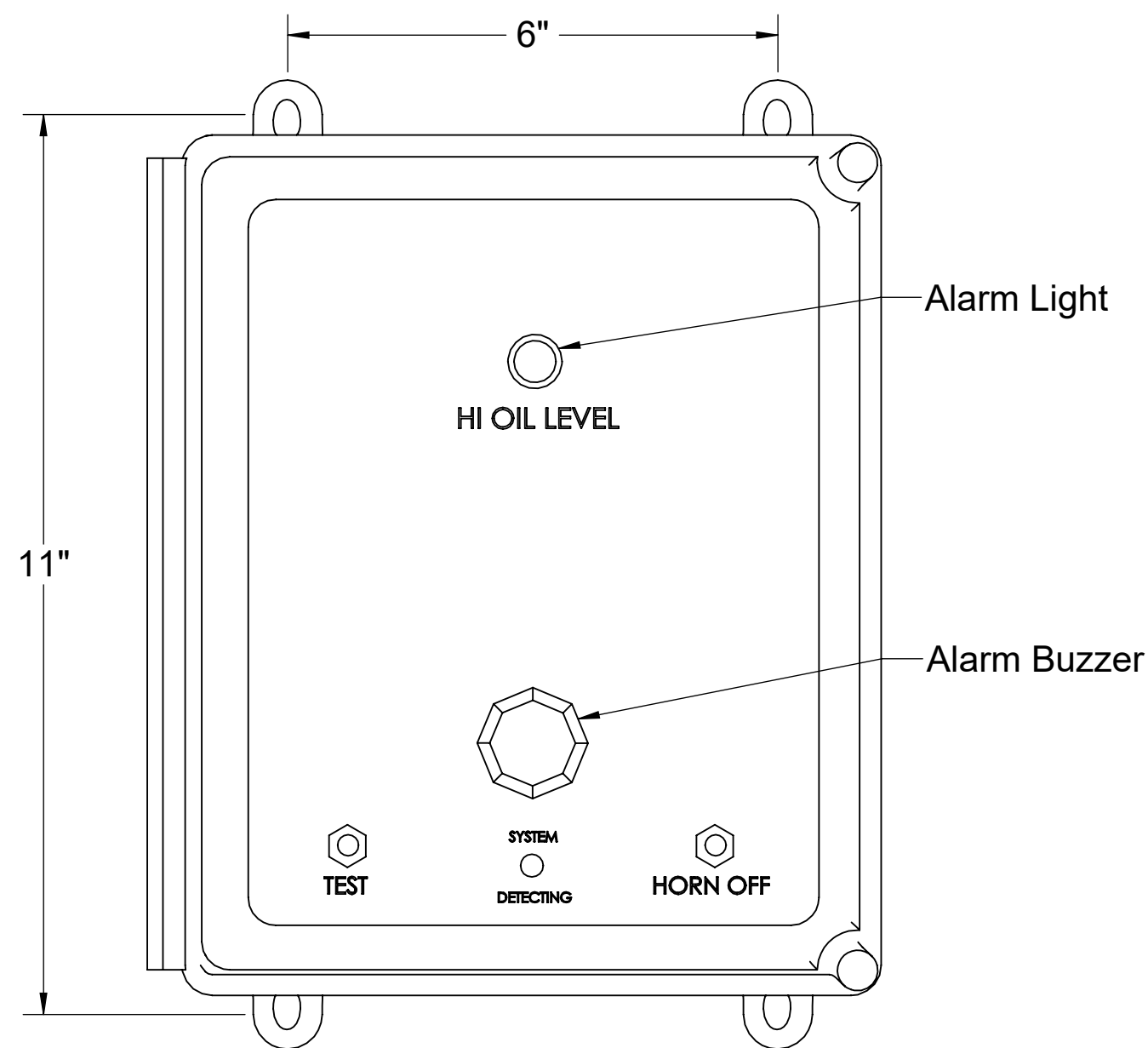
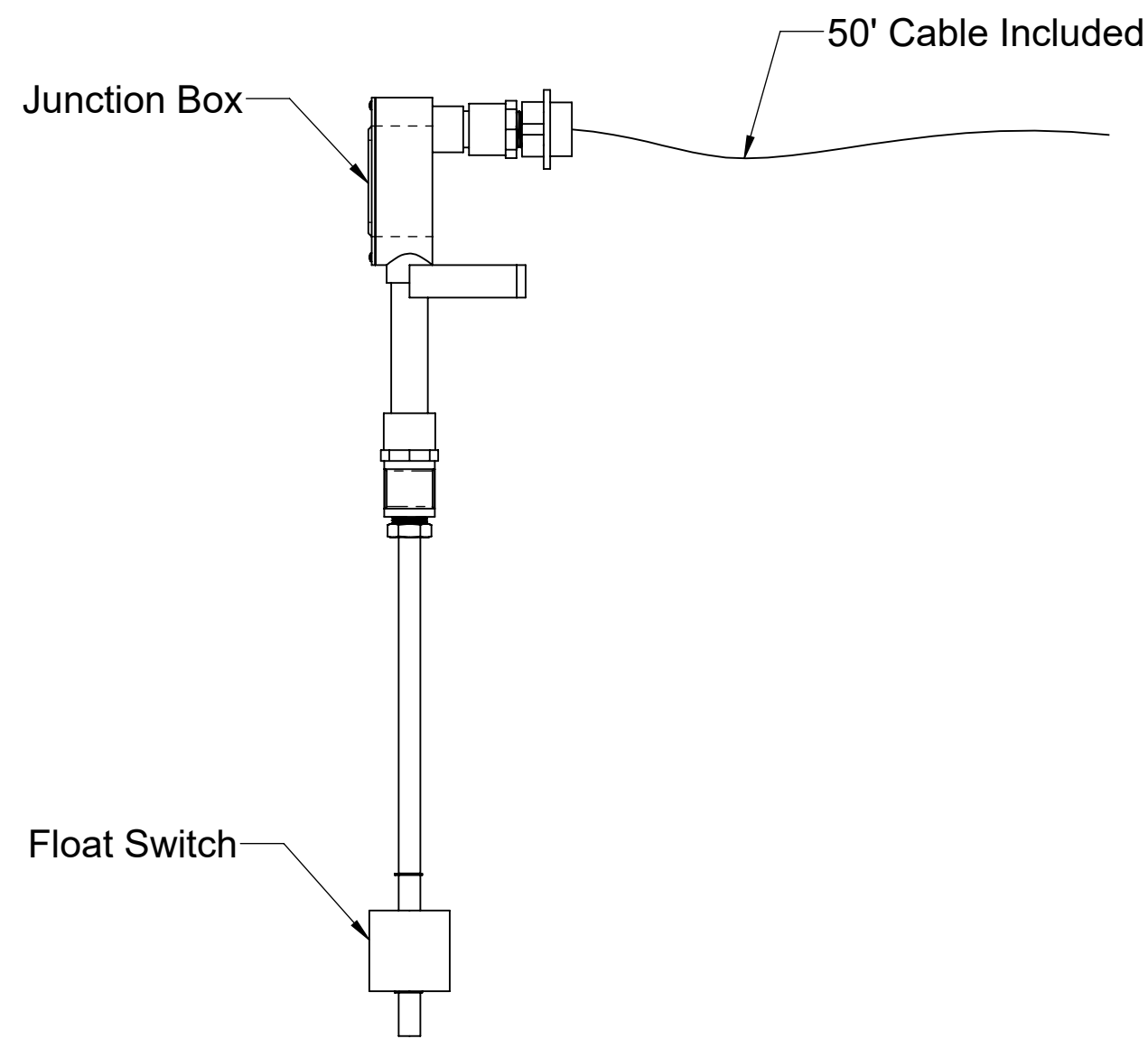

**FRONT VIEW**

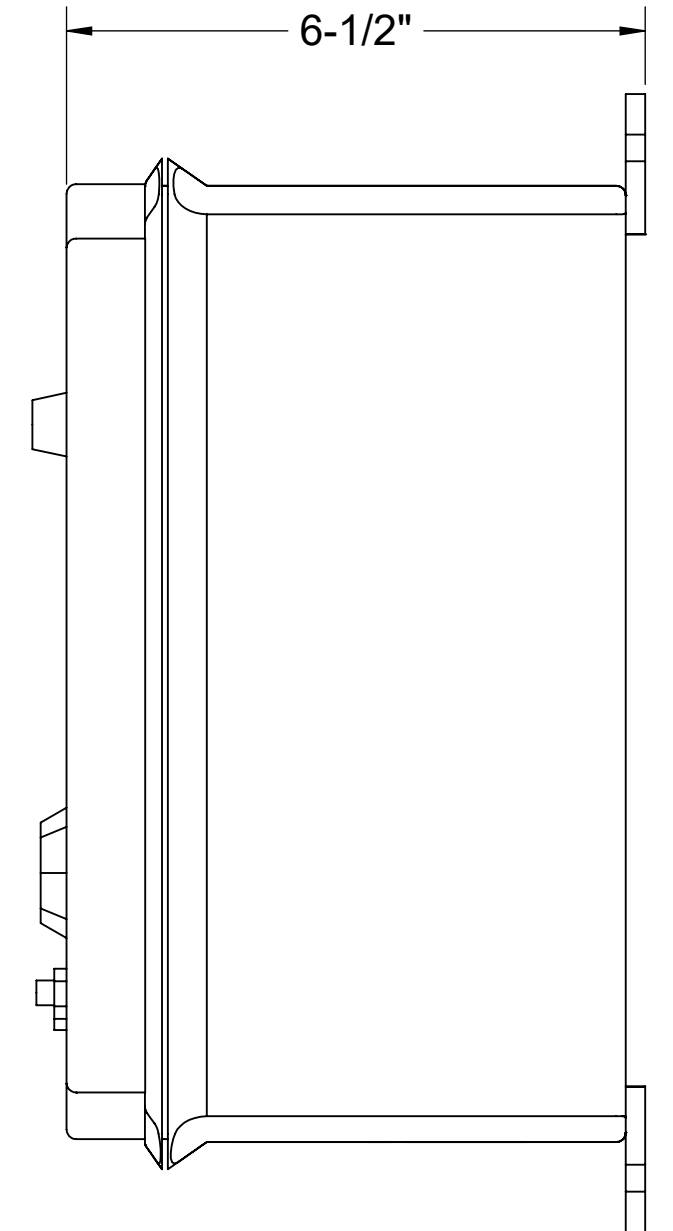

**LEFT VIEW**

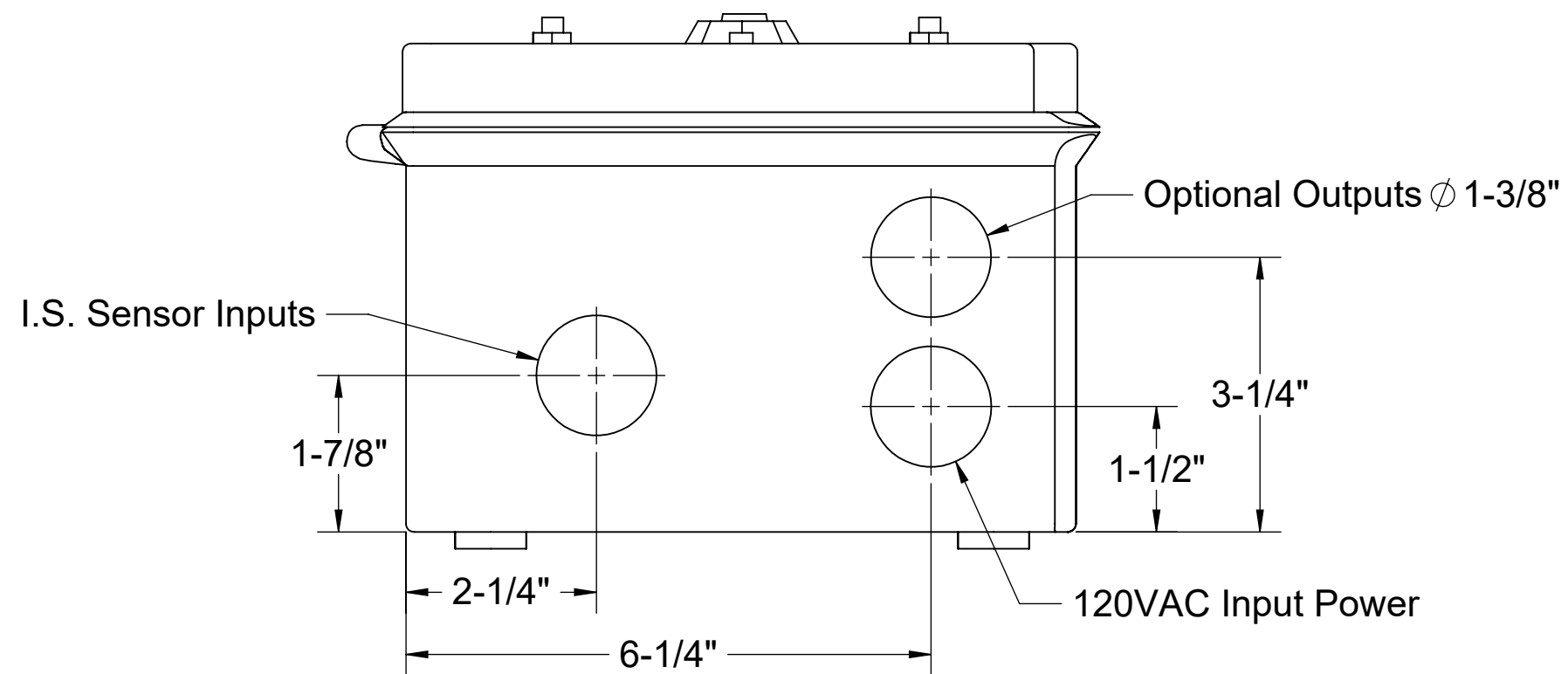

**BOTTOM VIEW**

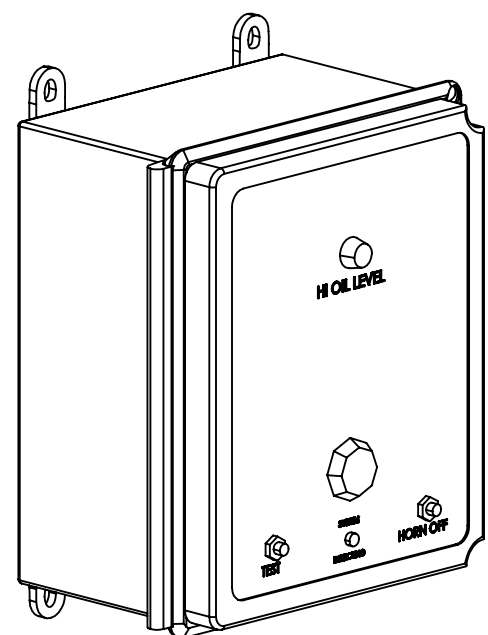

<b>MODEL NUMBER:</b> SS		<b>SPECIFICATION SHEET</b>	
<b>DESCRIPTION:</b>  SLICK STICK™ OIL LEVEL MONITORING SYSTEM			
<b>DWG BY:</b> ENG		<b>DATE:</b> 5/19/2023	
<b>REV:</b> 0		<p>Striem Kansas City, KS Tel: 913-222-1500 orders@striemco.com www.striemco.com</p> <p>Made in the U.S.A</p> 	

**PROPRIETARY AND CONFIDENTIAL**  
THE INFORMATION CONTAINED IN THIS DRAWING IS THE SOLE PROPERTY OF STRIEM, LLC.  
ANY REPRODUCTION IN PART OR AS A WHOLE WITHOUT THE WRITTEN PERMISSION OF STRIEM, LLC. IS PROHIBITED.