



TELEGLIDE RISER SYSTEM INSTALLATION INSTRUCTIONS

OIL SEPARATOR (OS)

TANK MODEL	MAX RISER HEIGHT	CUT LINE DIMENSION	MAX RISER HEIGHT WITH SLICK STICK™	CUT LINE DIMENSION
OS-35	37"	X + 2.25"	N/A	N/A
OS-50	37"	X + 2.25"	36"	X + 7.75"
OS-75	72"	X + 5.25"	69"	X + 7.75"
OS-100	90"	X + 5.25"	87"	X + 7.75"
OS-750	106"	X + 5.25"	103"	X + 7.75"
OS-1000	106"	X + 5.25"	103"	X + 7.75"
OS-1500	106"	X + 5.25"	103"	X + 7.75"

OIL TANKER (OT)

TANK MODEL	MAX RISER HEIGHT	CUT LINE DIMENSION	MAX RISER HEIGHT WITH SLICK STICK™	CUT LINE DIMENSION
OT-500	106"	X + 2.25"	103"	X + 7.75"
OT-750	106"	X + 5.25"	103"	X + 7.75"
OT-1000	106"	X + 5.25"	103"	X + 7.75"
OT-1500	106"	X + 5.25"	103"	X + 7.75"

AARDVARK (AA)

TANK MODEL	MAX RISER HEIGHT	CUT LINE DIMENSION
AA-M	37"	X + 2.25"
AA-L	37"	X + 2.25"
AA-XL	72"	X + 5.25"

PROSPECTOR (PS)

TANK MODEL	MAX RISER HEIGHT	CUT LINE DIMENSION
PS-35	37"	X + 2.25"
PS-50	37"	X + 2.25"
PS-125	72"	X + 5.25"
PS-275	90"	X + 5.25"

CATCH BASIN (CB)

TANK MODEL	MAX RISER HEIGHT	CUT LINE DIMENSION
CB-50-S	37"	X + 2.25"
CB-125-S	72"	X + 5.25"
CB-275-S	90"	X + 5.25"
CB-50-G	37"	X + 2.25"
CB-125-G	70"	X + 2.25"
CB-50-SFL	37"	X + 2.25"
CB-125-SFL	72"	X + 5.25"
CB-275-SFL	90"	X + 5.25"
SI-UPC-1016	87"	X + 5.25"

LAB BASIN (LB)

TANK MODEL	MAX RISER HEIGHT	CUT LINE DIMENSION
LB-35	37"	X + 2.25"
LB-50	37"	X + 2.25"
LB-125	72"	X + 5.25"
LB-275	90"	X + 5.25"
LB-500	106"	X + 5.25"
LB-750	106"	X + 5.25"
LB-1000	106"	X + 5.25"
LB-1500	106"	X + 5.25"

BIO BASIN (BB)

TANK MODEL	MAX RISER HEIGHT	CUT LINE DIMENSION	MAX RISER HEIGHT WITH AVA	CUT LINE DIMENSION
BB-275	90"	X + 5.25"	87"	X + 7.75"
BB-500	106"	X + 5.25"	103"	X + 7.75"
BB-750	106"	X + 5.25"	103"	X + 7.75"
BB-1000	106"	X + 5.25"	103"	X + 7.75"
BB-1500	106"	X + 5.25"	103"	X + 7.75"

FLAMMABLE LIQUID INTERCEPTOR (FLI)

TANK MODEL	MAX RISER HEIGHT	CUT LINE DIMENSION	MAX RISER HEIGHT WITH SLICK STICK™	CUT LINE DIMENSION
FLI-125	72"	X + 5.25"	69"	X + 7.75"
FLI-275	90"	X + 5.25"	87"	X + 7.75"

INSPECTOR (INS)

TANK MODEL	MAX RISER HEIGHT	CUT LINE DIMENSION
Inspector	103"	X + 2.25"

OIL COLLECTION TANK (OCT)

TANK MODEL	MAX RISER HEIGHT	CUT LINE DIMENSION	MAX RISER HEIGHT WITH AVA	CUT LINE DIMENSION
OCT-50	37"	X + 2.25"	37"	X + 7.75"
OCT-125	72"	X + 5.25"	69"	X + 7.75"
OCT-275	90"	X + 5.25"	87"	X + 7.75"

TELEGLIDE RISER | INSTALLATION INSTRUCTIONS

- 1**
- Place unit so that the pipe connections line up with jobsite piping.
 - Measure dimension X to determine riser height needed.
 - Reference tables on other side** to determine unit's maximum riser height.
 - Select the required risers from the adjacent table. Riser chart shows quantity for each tank manway.

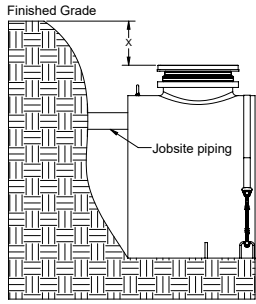

Cover Adapter	
Riser Height Needed	Risers Required Per Manway
0" - 5"	None
5" - 24"	SR24 (1)
24" - 39"	LR24 (1)
39" - 43"	SR24 (2)
43" - 58"	SR24 (1), LR24 (1)
58" - 72"	LR24 (2)
72" - 90"	SR24 (1), LR24 (2)
90" - 106"	LR24 (3)
Cover Adapter with Monitoring equipment	
0 - 2"	None
2" - 21"	SR24 (1)
21" - 36"	LR24 (1)
36" - 40"	SR24 (2)
40" - 55"	SR24 (1), LR24 (1)
55" - 69"	LR24 (2)
69" - 87"	SR24 (1), LR24 (2)
87" - 103"	LR24 (3)

- 2**
- Loosen upper clamp with **nut driver bit (included with tank)**.
 - If no risers are needed, adjust cover adapter height as needed.
 - Ensure 2-1/2" minimum engagement is maintained.
 - If risers are needed, remove covers from cover adapters, and cover adapters from the unit.

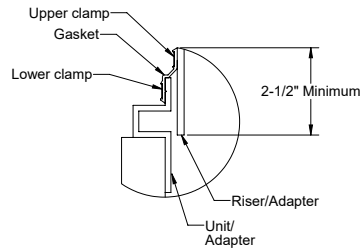

- 3**
- Insert cover adapters into the required risers until they stop.
 - Tighten upper clamp to keep risers from shifting. Risers are installed from short to long.
 - Reference table on other side to determine the Cut Line Dimension**
 - From the cover adapter, measure the **Cut Line Dimension** from the table, down the sidewall of the risers.
 - Mark the location with **china marker (included with tank)**.
 - Cover adapter may need to be adjusted outward for some dimension ranges. If mark is at the end of riser, no cutting is required.

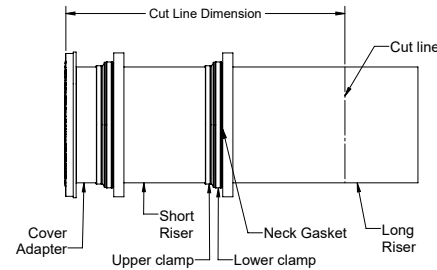

- 4**
- Uninstall cover adapters and risers.
 - Extend mark made in **step 3** around the circumference of the riser.
 - Cut along line with jigsaw, circular saw, or reciprocating saw.
 - Make a mark around the circumference of the riser 3" from the cut end of riser.
 - If no cuts were needed, make the mark 3" from the bottom of the bottom riser.

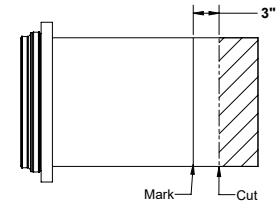

- 5**
- Wipe clean all riser and cover adapter sidewalls.
 - Insert the first riser into the tank neck until the mark made in **step 4** is in-line with the top of the neck gasket. This will ensure your risers reach the finished grade measured in **step 1**.

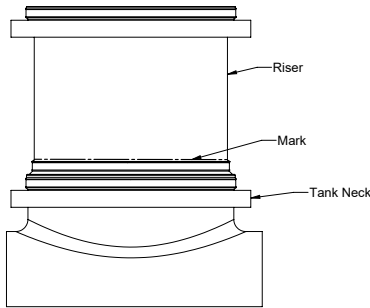

- 6**
- Install risers and cover adapters into the tank neck starting from the marked riser, moving up to finished grade.
 - Upper clamps may need to be loosened or removed to aid in assembly.

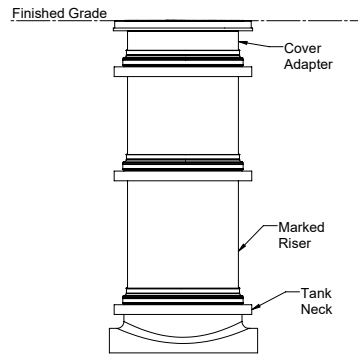

- 7**
- Tighten all clamps to 14 lbs. of torque.
 - Reinstall covers on cover adapters.
 - If tilting of the cover adapter is required to be flush with finished floor, it must be done after all clamps are tightened. A 6.5° tilt is the maximum.

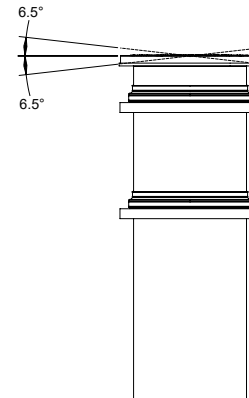

- 8**
- If jobsite riser height conditions change after the previous steps have been completed, there is still room for vertical adjustment.
 - As long as the minimum engagement of 2-1/2" on all joints are maintained, the adapters and risers may be adjusted/cut as many times as necessary.

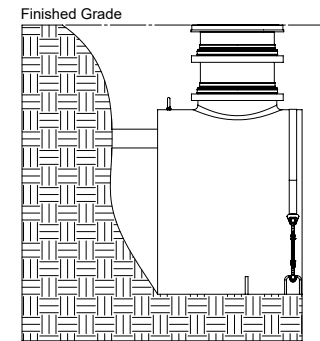

WARNING



DO NOT AIR PRESSURE TEST UNIT!
DOING SO MAY RESULT IN PROPERTY DAMAGE, SERIOUS BODILY INJURY, OR DEATH!
Refer to Installation Instructions for correct testing procedure.

FOR BURIED APPLICATIONS ONLY LEAK/SEAL TESTING

Do not air test unit or Teleglide Riser system! Doing so may result in property damage, personal injury or death. To perform a leak/seal test on the base unit, cap/plug all plumbing connections, remove the cover, and fill the unit with water just above the highest connection. Inspect unit and connections for leaks. Check water level at specific time intervals per local code. Note: This unit has been subjected to a 24 hour water test prior to shipment from the factory.



913-222-1500



HELP@STRIEMCO.COM



STRIEMCO.COM

CUSTOMER SERVICE HOURS: Mon-Fri, 8 am - 5 pm CST

