

SPECIFICATIONS

1. 1-1/2" or 2" FPT connections standard (polypropylene bushings included).
2. 3" gasketed top access port.
3. Liquid capacity: 2 Gallons (1-1/2"); 1.8 Gallons (2").
4. Unit weight: 6 lbs. (dry); 23 lbs. (wet); 36 lbs. (wet w/ limestone).
5. Maximum operating temperature 140°F continuous.

NOTES

1. Top inlet and side inlet options standard.
2. Built-in sewer gas trap.
3. Bottom of tank must be supported if not sitting on floor. Support must hold at least 50 lbs.
4. Uses: Neutralization (w/ limestone) or dilution (no limestone).

ENGINEER SPECIFICATION GUIDE

Striem neutralization tank model LB-2-ADA shall be lifetime guaranteed and made in the USA. Tank shall be constructed of polyethylene. Tank shall be manufactured for above-grade installation. Tank shall be furnished with (2) inlets and (1) outlet connection with bushings included to field-adapt to 1-1/2" or 2" drain line pipe size. Tank shall be watertight up to 36" head and contain an internal sewer gas trap. Tank shall have gasketed cover.

INCLUDED

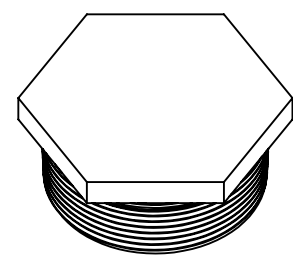

2" MPT Plug

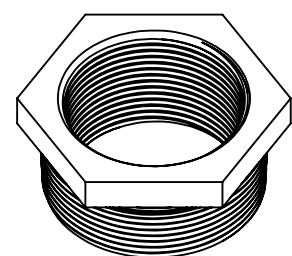

2" x 1-1/2" MPT Reducer (2)

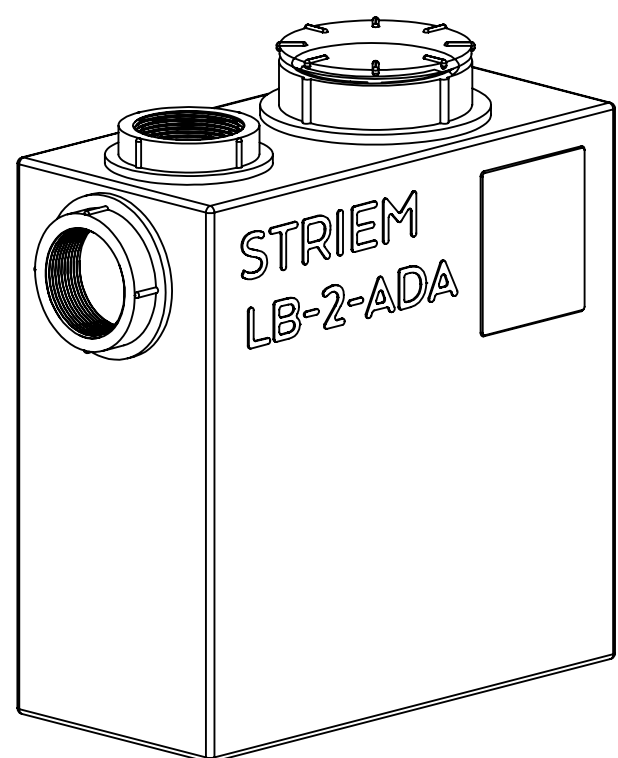

OPTIONS

Limestone: 90%+ Calcium Carbonate (25 lbs.)

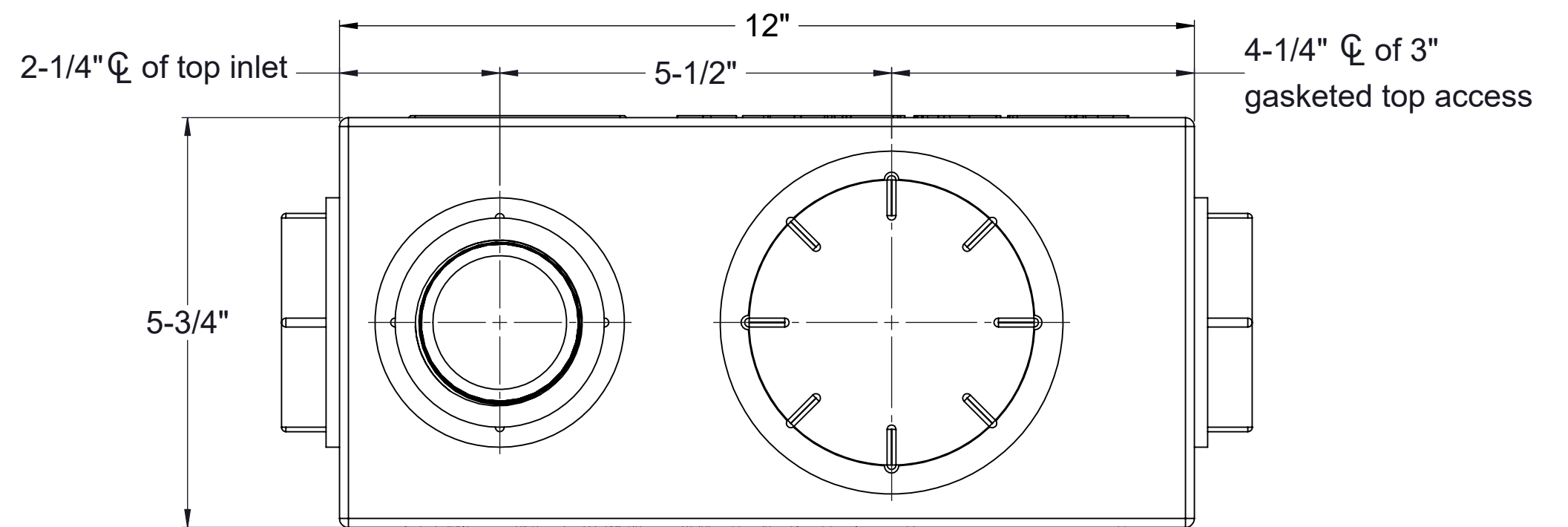

TOP VIEW

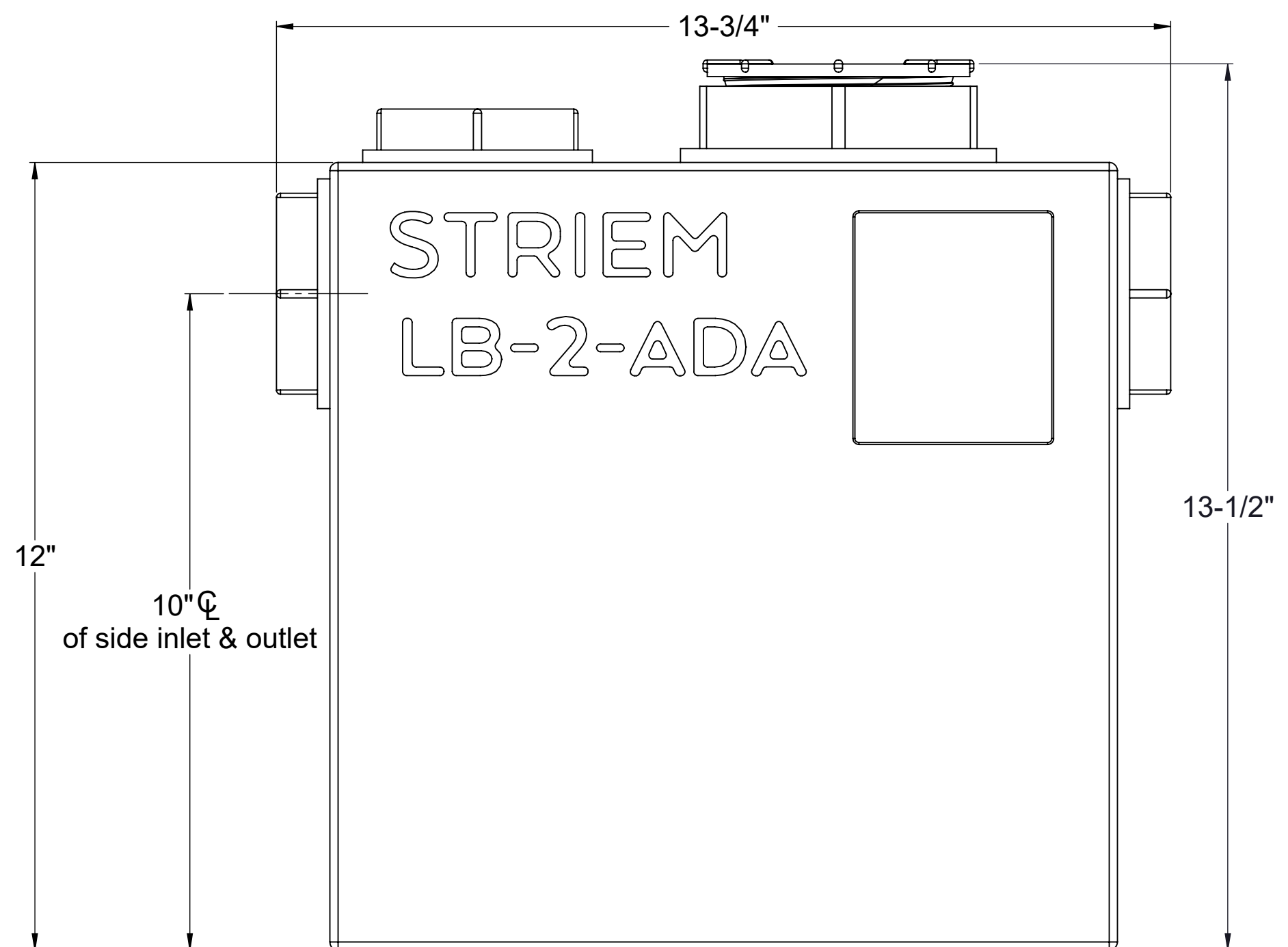

FRONT VIEW

MODEL NUMBER: LB-2-ADA		SPECIFICATION SHEET	
DESCRIPTION: LAB RAT™ POLYETHYLENE POINT OF USE NEUTRALIZATION TANK FOR ADA SINK			
DWG BY: ENG	DATE: 5/12/2023	REV: 0	Striem Kansas City, KS Tel: 913-222-1500 orders@striemco.com www.striemco.com Made in the U.S.A

PROPRIETARY AND CONFIDENTIAL
 THE INFORMATION CONTAINED IN THIS DRAWING IS THE SOLE PROPERTY OF STRIEM, LLC.
 ANY REPRODUCTION IN PART OR AS A WHOLE WITHOUT THE WRITTEN PERMISSION OF STRIEM, LLC. IS PROHIBITED.