

SPECIFICATIONS

1. UL Listed
2. Provides warning of high oil level conditions with interface float.
3. Single phase, 120 volt, 60 hertz power required.
4. NEMA 4X fiberglass, corrosion resistant, weatherproof enclosure suitable for outdoor use and damp environments.
5. Audible Alarm Buzzer, 95dB pulsing horn with no timeout.
6. High Oil Light, indicates oil has accumulated below the oil interface float or the tank liquid level is below the High Oil Interface Float.
7. Power On light inside enclosure. Visible from the outside. Green light indicates the power is on.
8. Horn off button that silences the audible alarm when pressed.
9. Test button that when pressed will test the system electronics.
10. Locking clasp on door.
11. Alarm bell stays on until reset. Light stays on until reset, even if level goes down.
12. Unit comes supplied with extra dry contact for connection to a building alarm system.

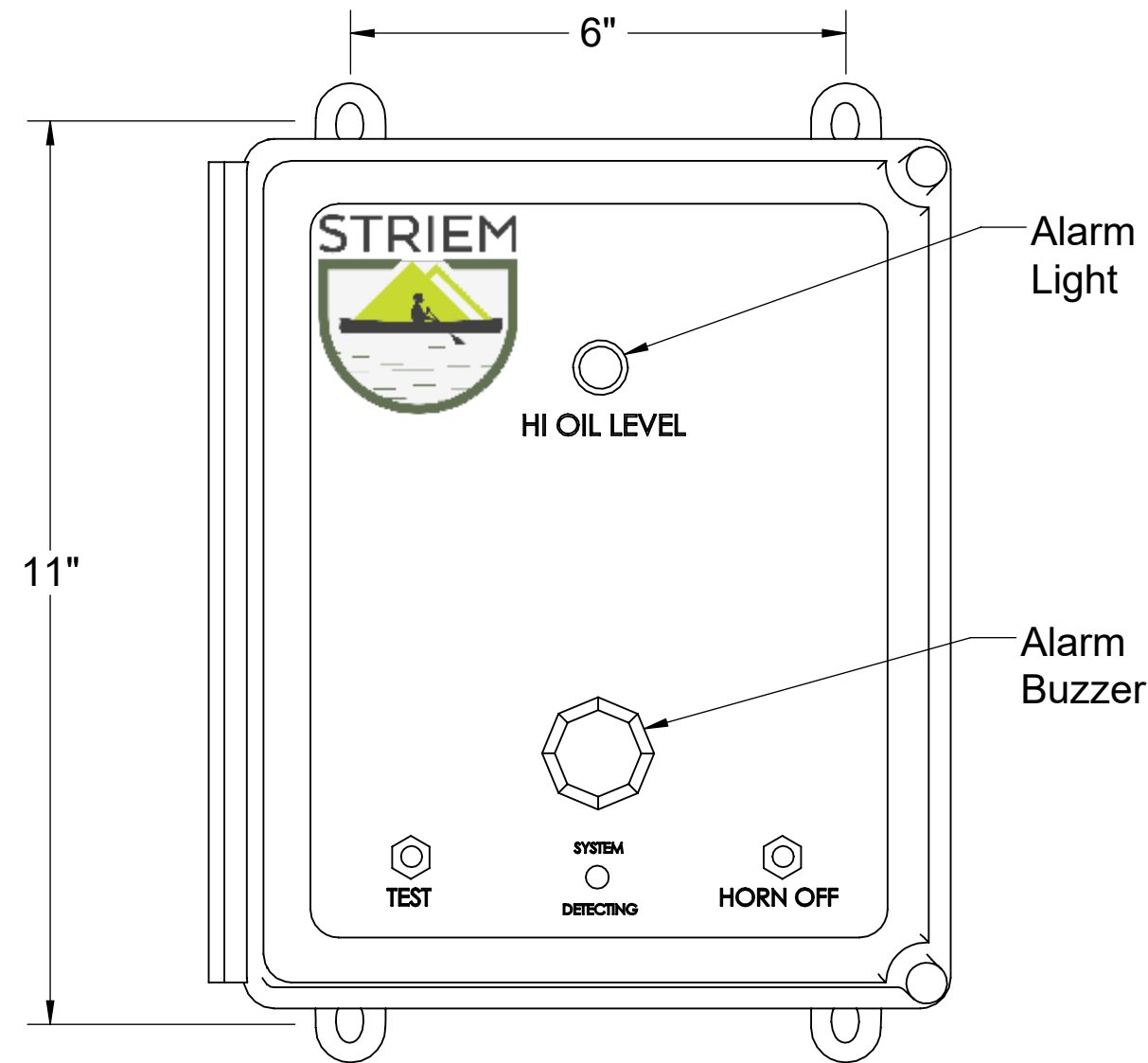

FRONT VIEW

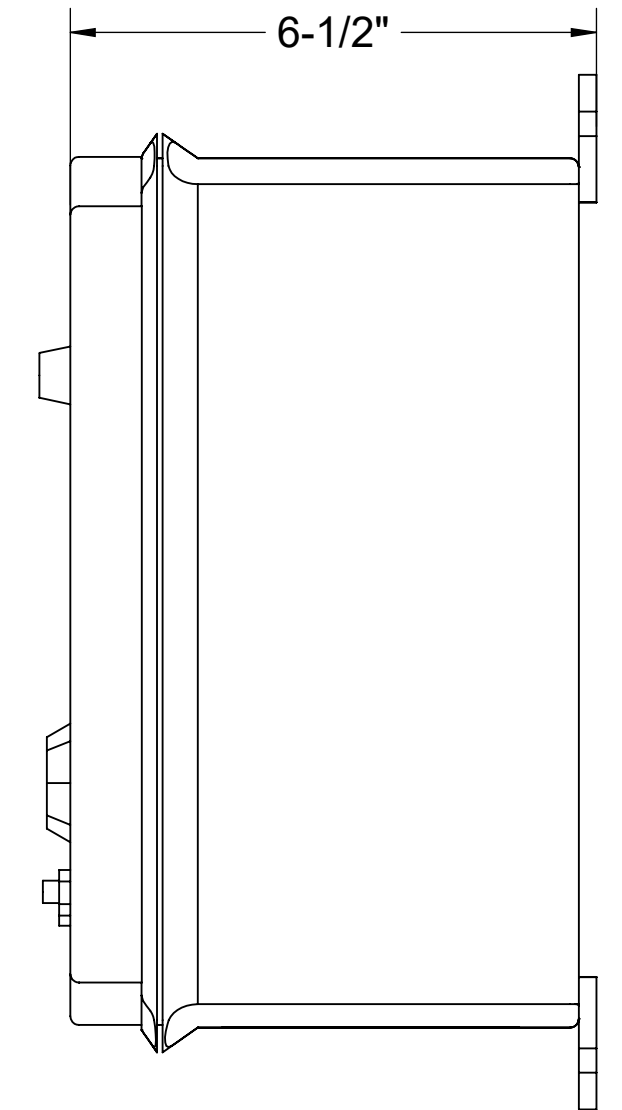

LEFT VIEW

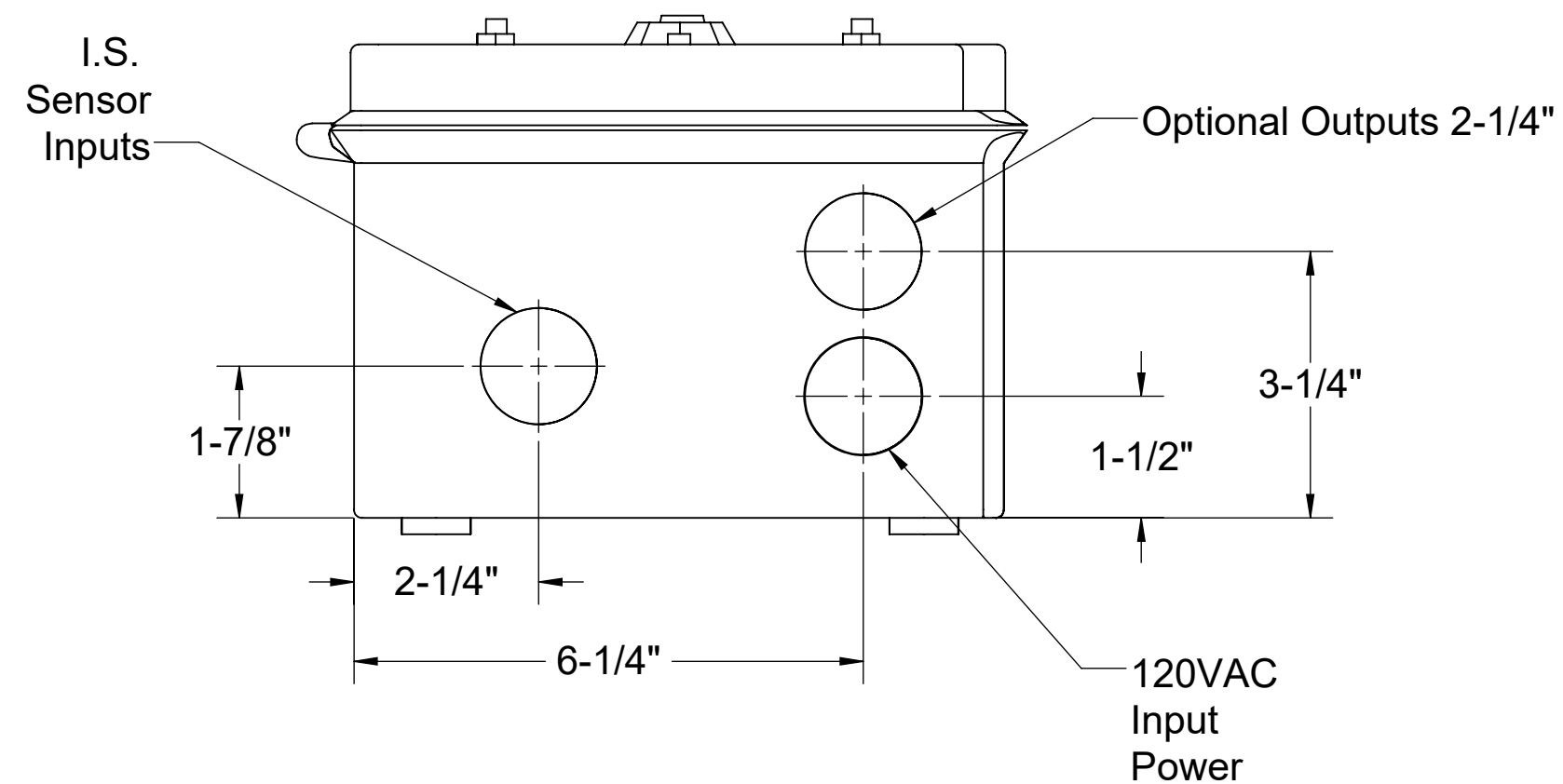

BOTTOM VIEW

MODEL NUMBER: 8056-001-01		SPECIFICATION SHEET	
DESCRIPTION: SLICK STICK™ OIL LEVEL MONITORING SYSTEM FOR OS-50, OS-75, & OS-100			
DWG BY: MJ		DATE: 11/15/18	
REV:		ECO:	
		<p>Striem 3100 Brinkerhoff Kansas City, KS 66115 Tel: 913-222-1500 Fax: 913-291-0457 www.striemco.com</p> <p>Made in the U.S.A</p>	

PROPRIETARY AND CONFIDENTIAL

THE INFORMATION CONTAINED IN THIS DRAWING IS THE SOLE PROPERTY OF STRIEM, LLC. ANY REPRODUCTION IN PART OR AS A WHOLE WITHOUT THE WRITTEN PERMISSION OF STRIEM, LLC IS PROHIBITED.

Striem Slick Stick™ Connection Diagram

COLOR CODE

CABLES FROM SENSORS TO REMOVABLE SENSOR INPUT CONNECTORS

1	RED	SENSOR #1 OWI-1
2	UNUSED	
3	UNUSED	
4	UNUSED	
5	UNUSED	
6	UNUSED	
7	BLACK	FROM SENSOR #1
8	SHIELD DRAIN	FROM SENSOR #1

WIRES TO OPTION BOARD

WIRES FROM RA-SERIES REMOTE

1	GREEN	-HORN
2	RED	+HORN
3	BLACK	GROUND
4	WHITE	HIGH OIL LEVEL
5	UNUSED	
6	UNUSED	

WIRES FROM RELAY OUTPUTS

7	UNUSED	
8	UNUSED	
9	UNUSED	
10	UNUSED	
11	COMMON	HIGH OIL LEVEL
12	NORMALLY OPEN	

120VAC

WIRES TO POWER SUPPLY

F.G.	FIELD GROUND
L	LINE
N	NEUTRAL

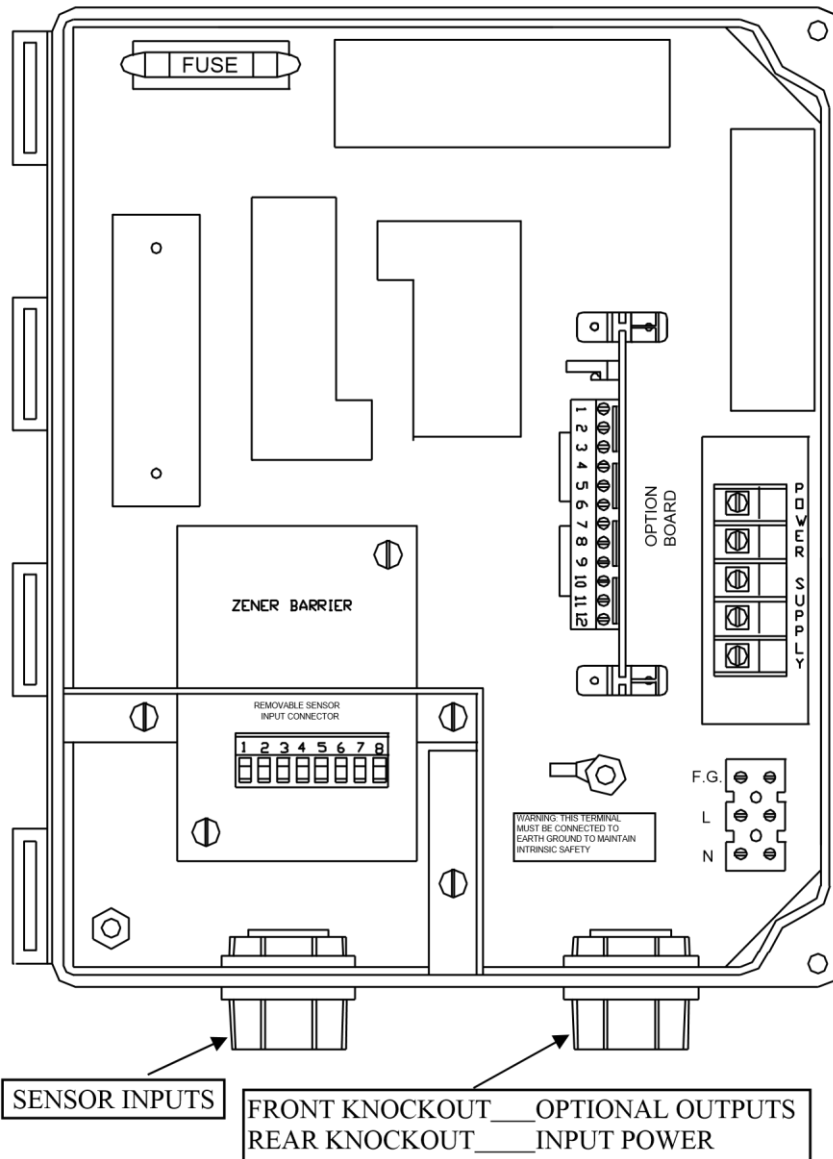

NOTE: To maintain proper shielding, BLACK sensor wires and SHIELD DRAINS should **not** be connected together at sensors.

Striem Slick Stick™ System Control Drawing

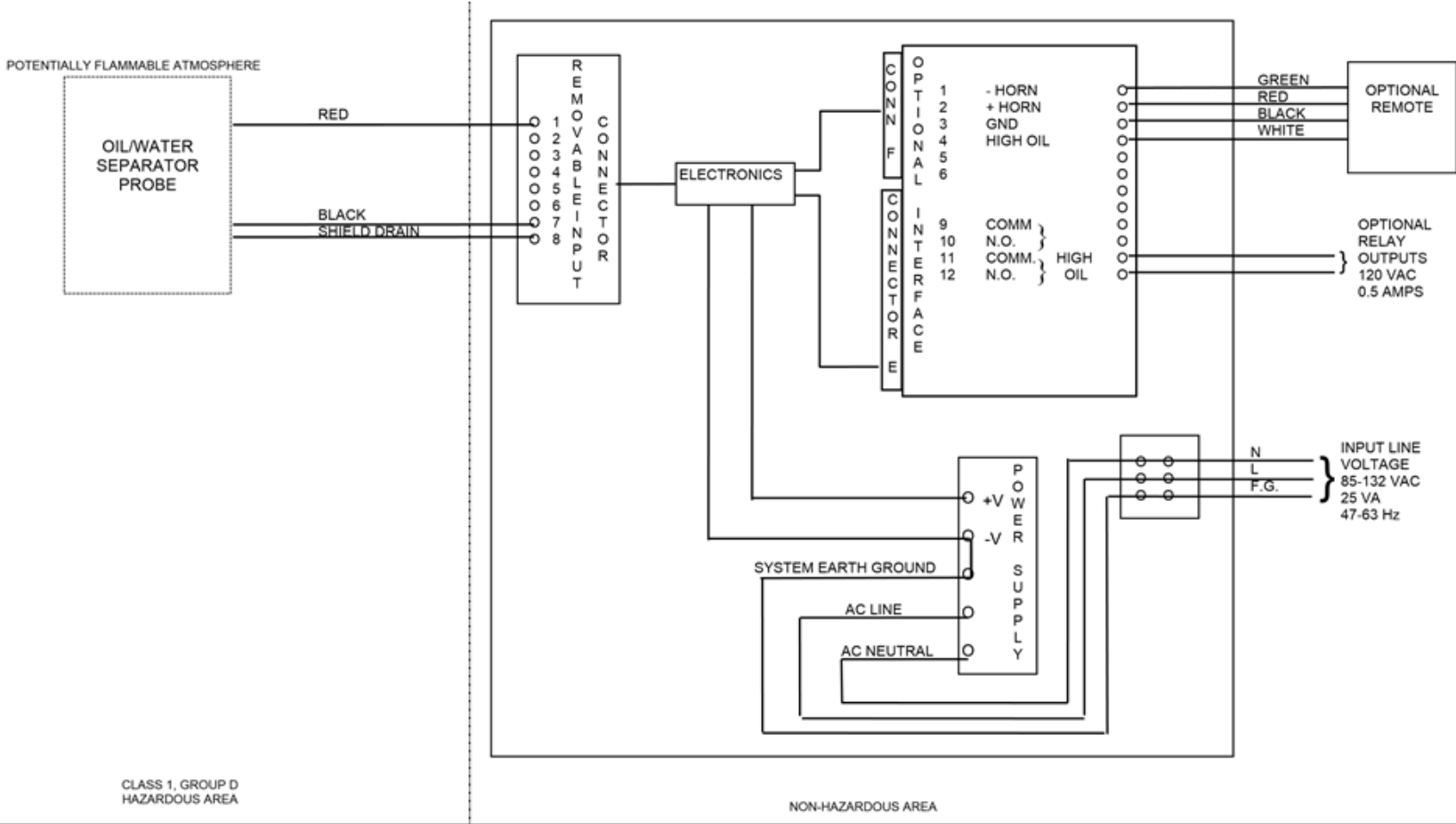

CLASS 1, GROUP D
HAZARDOUS AREA

NON-HAZARDOUS AREA

NOTES ON PROBES

1. THE INSTRINSICALLY SAFE FIELD WIRING SHALL BE INSTALLED IN ACCORDANCE WITH ARTICLE 504 IN THE NATIONAL ELECTRICAL CODE ANSINFPFA 70
2. ALL PROBES ARE ELECTRICALLY IDENTICAL AND MAY BE INTERCHANGED ALLOWING SYSTEM FLEXIBILITY
3. PROBE TO CONTROL UNIT CABLE WILL BE TWO PAIR OF #22 AWG WITH SHIELD AND DRAIN PVC JACKETED UL-118830 CM. CABLE LENGTH WILL BE LIMITED TO 2000 FEET MAXIMUM

NOTES ON CONTROL EQUIPMENT

1. ALL WIRING MUST MEET LOCAL AND NATIONAL ELECTRICAL CODES
2. SYSTEM EARTH GROUND MUST BE CONNECTED TO TERMINAL F.G. TO INSURE INTRINSIC SAFETY AND MUST BE LESS THEN 1Ω WITH RESPECT TO EARTH GROUND
3. OPTIONAL REMOTE REQUIRES #22 AWG LOW VOLTAGE COMMUNICATION CABLE MINIMUM

Installation Guidelines:

1. The Slick Stick™ interface float and alarm panel will ship separately from the tank.
2. Install the 1/2" FPT brass coupling to the end of the Slick Stick™ interface float. Thread the 1/2" MPT x socket PVC fitting into the 1/2" FPT brass coupling.
3. If the tank is to be installed above grade, or without any adjustment to the adapter, install a length of 1/2" sch. 40 PVC pipe between the bottom of the junction box and the top of the 1/2" MPT x socket PVC fitting. Choose the length from Table 1 that corresponds with the unit, and oil capacity to be monitored.
4. If the tank is buried, and the adapter will be adjusted upward and/or risers will be used, add the total upward extension dimension to the length determined from Table 1 to determine total length of 1/2" PVC pipe length. For example, assume an OS-75 is being installed below grade and requires 26" of riser extension. Assume you want the control panel to alarm when the oil capacity reaches 70% of the total oil capacity. The length of the 1/2" PVC pipe extension should be 26" (riser depth) + 10" (from Table 1) = 36".
5. Run interface float wiring through 1/2" PVC pipe and into the bottom of the junction box inside the adapter. Connect wiring to alarm panel (see wire diagram).

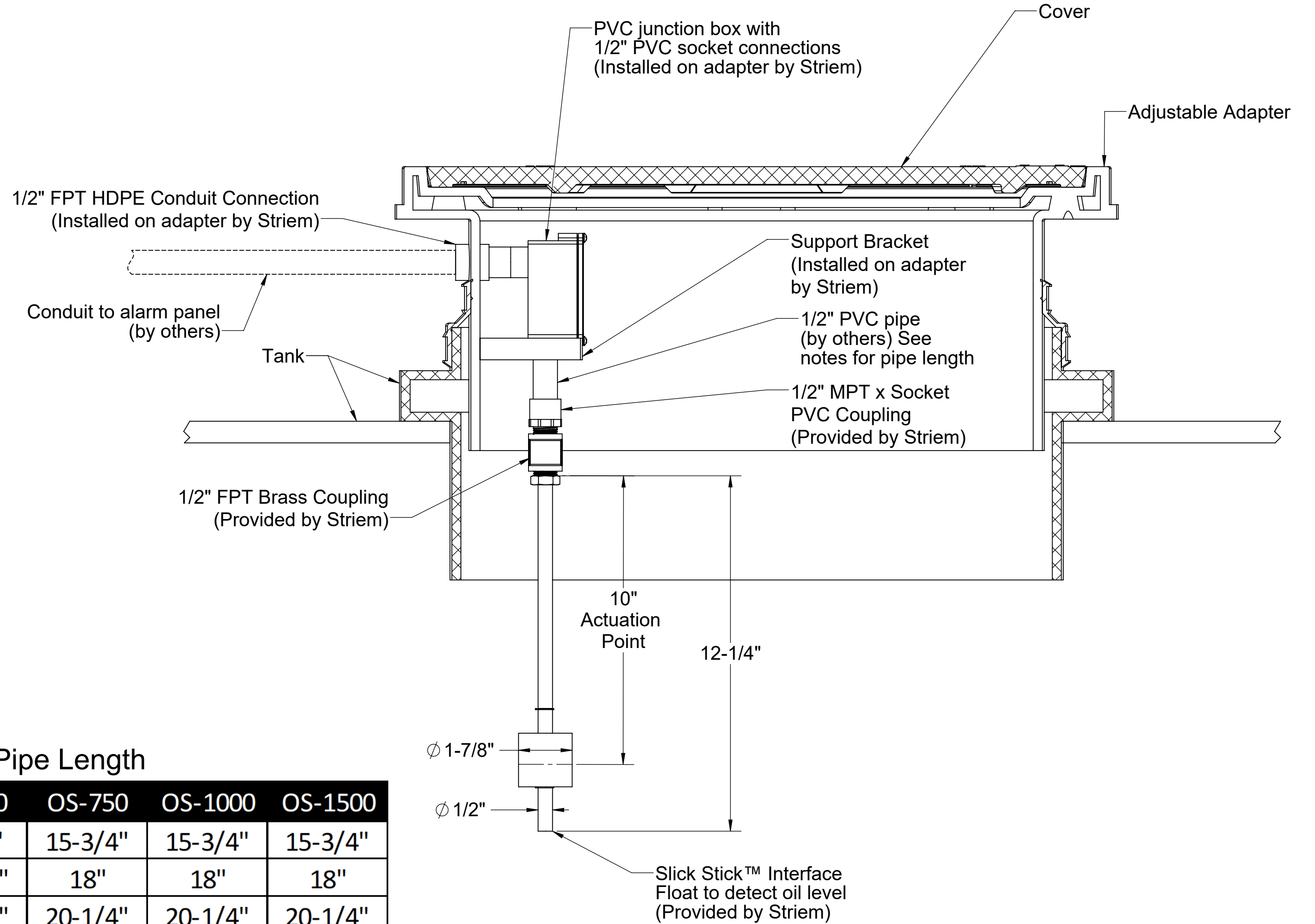

Table 1: 1/2" PVC Pipe Length

Oil Capacity	OS-50	OS-75	OS-100	OS-750	OS-1000	OS-1500
50%	1-1/2"	6-5/8"	9-5/8"	15-3/4"	15-3/4"	15-3/4"
60%	2-3/8"	8-1/4"	11-1/2"	18"	18"	18"
70%	3-3/8"	10"	13-1/4"	20-1/4"	20-1/4"	20-1/4"
80%	4-3/8"	12"	15"	22-1/2"	22-1/2"	22-1/2"
90%	5-1/2"	13-7/8"	18-3/4"	24-1/2"	24-1/2"	24-1/2"

DESCRIPTION:

**SLICK STICK™
INTERFACE FLOAT
INSTALLATION GUIDELINES**

Striem
3100 Brinkerhoff
Kansas City, KS 66115
Tel: 913-222-1500
Fax: 913-291-0457
www.striemco.com



Made in the U.S.A

DWG BY: MJ DATE: 12/17/18 REV: ECO:

PROPRIETARY AND CONFIDENTIAL
THE INFORMATION CONTAINED IN THIS DRAWING IS THE SOLE PROPERTY OF STRIEM, LLC.
ANY REPRODUCTION IN PART OR AS A WHOLE WITHOUT THE WRITTEN PERMISSION OF STRIEM, LLC. IS PROHIBITED.