

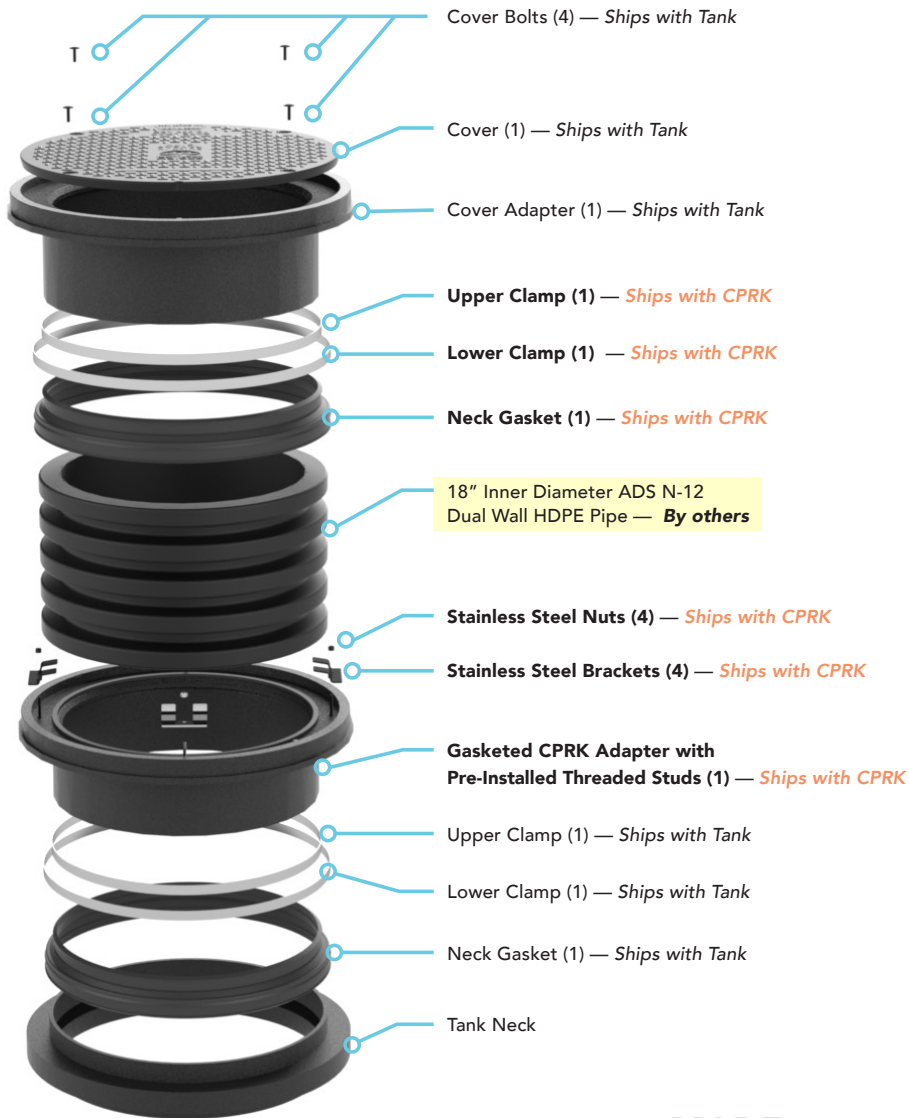

CORRUGATED PIPE RISER KIT (CPRK) INSTALLATION INSTRUCTIONS

Uses 18" Inner Diameter ADS N-12 Dual Wall HDPE Pipe (*by others*)

(1) CPRK REQUIRED PER MANWAY



PRODUCT COMPATIBILITY & MAX BURIAL DEPTH

OIL SEPARATORS

OS SERIES

TANK MODEL	BURIAL DEPTH RANGE
OS-75	11"-72"
OS-100	11"-90"
OS-350	11"-90"

OIL TANKER™ SERIES

TANK MODEL	BURIAL DEPTH RANGE
OT-500	11"-106"
OT-750	11"-106"
OT-1000	11"-106"
OT-1500	11"-106"
OT-2000	11"-106"

SOLIDS INTERCEPTORS

TANK MODEL	BURIAL DEPTH RANGE
CB-125-S	11"-72"
CB-275-S	11"-90"
CB-500-S	11"-106"
CB-750-S	11"-106"
CB-1000-S	11"-106"
CB-1500-S	11"-106"
CB-2000-S	11"-106"

MARKET SPECIFIC

TANK MODEL	BURIAL DEPTH RANGE
CB-1000-SFL	11"-106"
CB-1500-SFL	11"-106"
FLI-125	11"-72"
FLI-275	11"-90"
FLI-500	11"-106"
FLI-750	11"-106"
FLI-1000	11"-106"
FLI-1500	11"-106"
FLI-2000	11"-106"
FWT-35	12"-90"
OCT-125	11"-72"
OCT-275	11"-90"
OS-100-OMAHA	11"-90"
OS-500-OMAHA	11"-106"

CHEMICAL WASTE TANKS

TANK MODEL	BURIAL DEPTH RANGE
LB-125	11"-72"
LB-275	11"-90"
LB-500	11"-106"
LB-750	11"-106"
LB-1000	11"-106"
LB-1500	11"-106"
LB-2000	11"-106"

TANK MODEL	BURIAL DEPTH RANGE
BB-275	11"-90"
BB-500	11"-106"
BB-750	11"-106"
BB-1000	11"-106"
BB-1500	11"-106"
BB-2000	11"-106"

SENSOR PLACEMENT KIT	BURIAL DEPTH RANGE
SPK	11"-103"



CORRUGATED PIPE RISER KIT (CPRK) | INSTALLATION INSTRUCTIONS

- 1**
- Place unit so that the pipe connections line up with jobsite piping.
 - Measure dimension X to determine riser height needed.
 - If X is less than 11", SR-24/LR-24 Risers must be used.

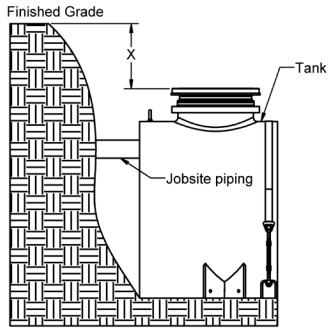

- 2**
- If corrugated pipe has an end piece, mark the corrugation valley closest to the end piece with **china marker (included with tank)**.

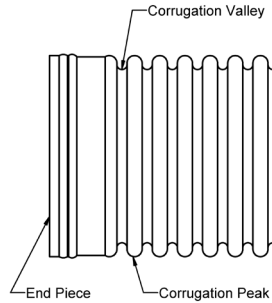

- 3**
- In the marked corrugation valley **from step 2**, mark the centerline of the corrugation valley around the circumference of the pipe using the **china marker**.
 - Cut along centerline with reciprocating saw, jigsaw, or circular saw.

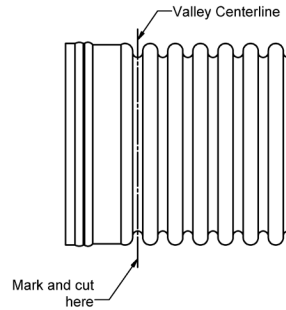

- 4**
- Subtract 8.5" from the riser height needed, X, measured in **step 1**.
 - If adapter is equipped with monitoring system, instead subtract 6" from the riser height needed, X, measured in **step 1**.
 - Measure this dimension down the sidewall of the corrugated pipe.
 - Mark the location with **china marker**.
- E.g.: If Riser height needed is 30", measure $30 - 8.5" = 21.5"$.*

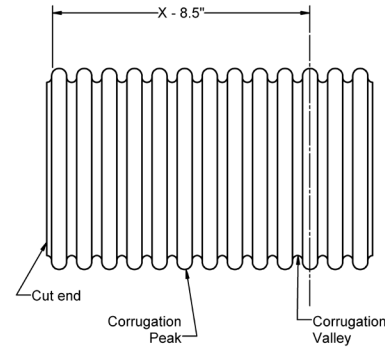

- 5**
- In the corrugation valley centerline that most closely precedes the mark **from step 4**, mark and cut along the centerline using the same method **from step 3**.

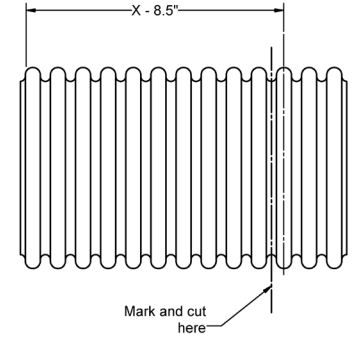

- 6**
- Remove cover from cover adapter.
 - On the cover adapter assembly, loosen the upper clamp with **nut driver bit (included with tank)**.
 - Remove cover adapter from tank.
 - Insert **gasketed CPRK adapter (included with CPRK)** until it stops.
 - Tighten upper clamp with **nut driver bit** using 14 lbs. of torque.

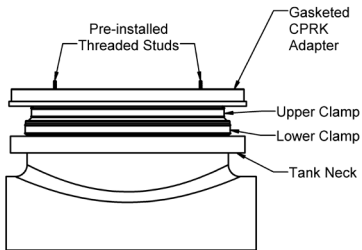

- 7***
- Place the corrugated pipe onto the **gasketed CPRK adapter (installed on the tank)**.
 - Center the corrugated pipe over the manway hole.
 - Slip **(4) steel brackets (included)** over the **(4) pre-installed threaded studs** so that the bracket tongues capture the pipe's bottom corrugation.
 - Hand-tighten the **(4) nuts (included)** onto the threaded studs. Tighten with nut driver using 8 lbs. of torque.

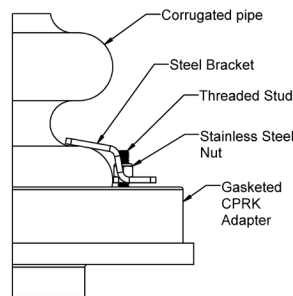

*Some installations may be eased by reversing steps 7 and 8.

- 8***
- Install the **neck gasket (included with CPRK)** onto the pipe's top corrugation, with the bottom of the neck gasket tangent to the bottom of the corrugation peak.
 - Install **lower clamp** on the neck gasket.
 - Tighten with nut driver using 14 lbs. of torque.
 - Place the cover adapter that was removed from the tank atop the corrugated pipe.
 - Install **upper clamp** on the neck gasket.
 - Tighten with nut driver using 14 lbs. of torque.

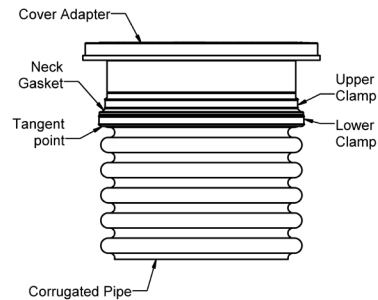

*Some installations may be eased by reversing steps 7 and 8.

- 9**
- If cover adapter is not level with finished grade, loosen the upper clamp installed on the tank neck.
 - Adjust the riser system upward to reach finished grade.
 - When cover adapter is level with grade, tighten the upper clamp with nut driver using 14 lbs. of torque.

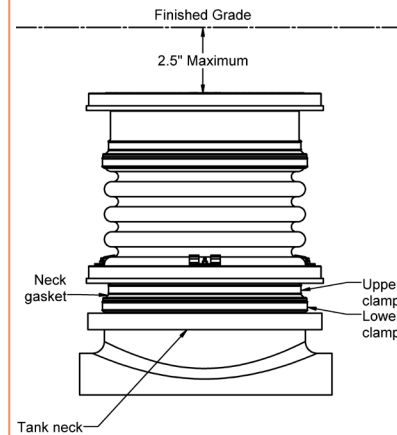

- 10**
- Reinstall cover on cover adapter.
 - Verify all clamps have been tightened to 14 lbs. of torque prior to backfill.
 - Verify all nuts have been tightened to 8 lbs. of torque prior to backfill.

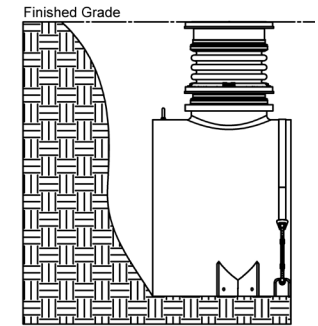

WARNING

DO NOT AIR PRESSURE TEST UNIT!
DOING SO MAY RESULT IN PROPERTY DAMAGE, SERIOUS BODILY INJURY, OR DEATH!
Refer to Installation Instructions for correct testing procedure.

FOR BURIED APPLICATIONS ONLY

LEAK/SEAL TESTING

Do not air test unit or Teleglide Riser system! Doing so may result in property damage, personal injury or death. To perform a leak/seal test on the base unit, cap/plug all plumbing connections, remove the cover, and fill the unit with water just above the highest connection. Inspect unit and connections for leaks. Check water level at specific time intervals per local code. Note: This unit has been subjected to a 24 hour water test prior to shipment from the factory.



913-222-1500



HELP@STRIEMCO.COM



STRIEMCO.COM

CUSTOMER SERVICE HOURS: Mon-Fri, 8 am - 5 pm CST