

**SPECIFICATIONS**

1. 1-1/2" or 2" PVC socket inlet and outlet connections (adapters included).
2. Under-sink solids interceptor.
3. PVC housing, polycarbonate perforated basket with o-ring to provide water-tight seal.
4. Top inlet and three outlet options (plugs included for unused outlets).
5. Max flow rate: 23 GPM.
6. Solids capacity: 0.17 gallons.
7. Unit weight: 3.2 lbs.
8. Maximum operating temperature: 140°F continuous.
9. For gravity drainage applications only.

**ENGINEER SPECIFICATION GUIDE**

Striem solids interceptor model SIDEKICK shall be lifetime guaranteed and made in the USA. Interceptor shall be constructed of an injection molded PVC housing and polycarbonate perforated basket. Interceptor shall be certified to IAPMO/ANSI/CAN Z1167 and carry a UPC listing. Interceptor is manufactured for above-grade installation. Basket shall provide the ability for side-access maintenance and shall be clear to allow visibility into unit. Solids capacity shall be 0.17 gallons.

**INCLUDED**

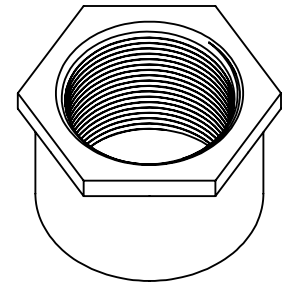

2" x 1-1/2" NPS  
PVC Adapter

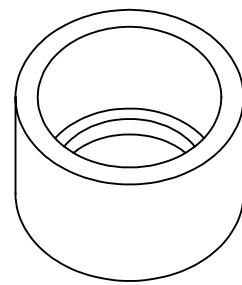

2" x 1-1/2"  
PVC Adapter (2)

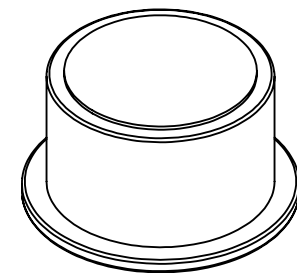

2" Inverted  
PVC Plug (2)

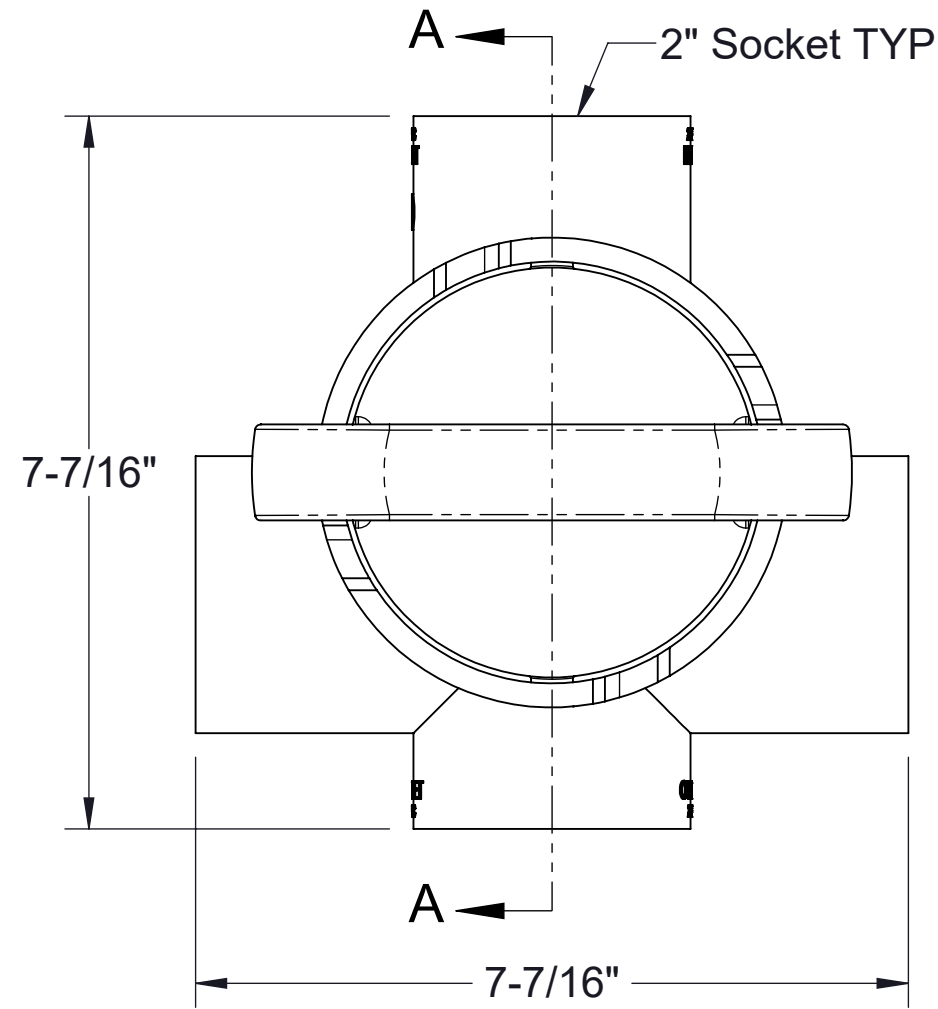

**FRONT VIEW**

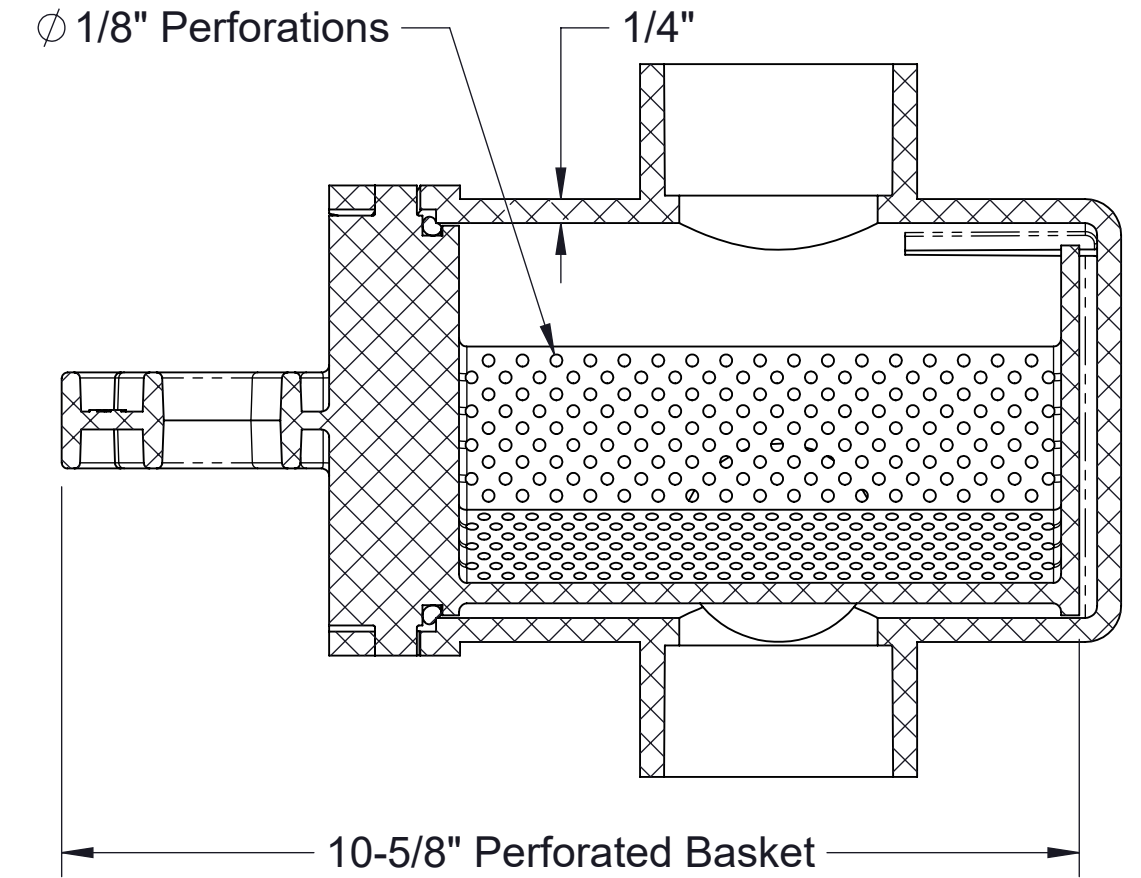

**SECTION A-A**

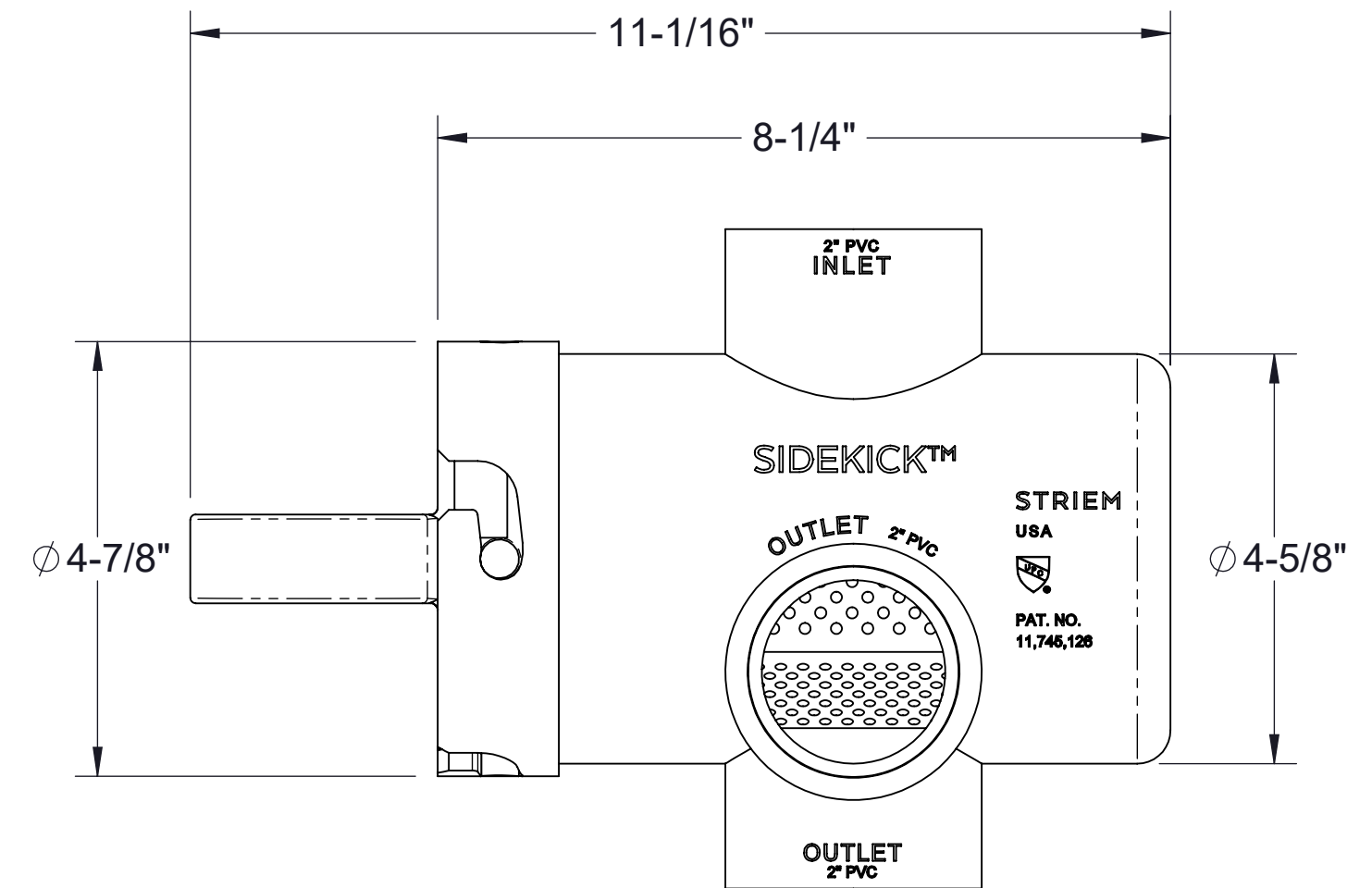

**SIDE VIEW**

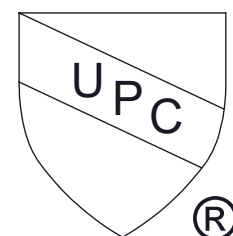
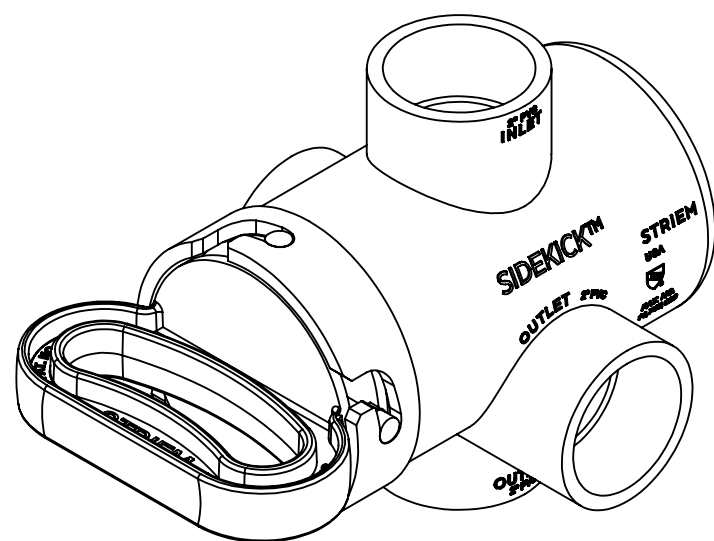

US Patent No.  
US11745126B2

**PROPRIETARY AND CONFIDENTIAL**

THE INFORMATION CONTAINED IN THIS DRAWING IS THE SOLE PROPERTY OF STRIEM, LLC. ANY REPRODUCTION IN PART OR AS A WHOLE WITHOUT THE WRITTEN PERMISSION OF STRIEM, LLC. IS PROHIBITED.

<b>MODEL NUMBER:</b> SIDEKICK		<b>SPECIFICATION SHEET</b>	
<b>DESCRIPTION:</b>			
SIDEKICK™ SIDE ACCESS SOLIDS INTERCEPTOR		Striem Kansas City, KS Tel: 913-222-1500 orders@striemco.com www.striemco.com  Made in the U.S.A	
<b>DWG BY:</b> ENG	<b>DATE:</b> 11/1/2024		