

SPECIFICATIONS

1. 3" Plain end vents standard.
2. Max flow rate: 314 GPM
3. Liquid capacity: 750 Gallons (100.3 cu. ft.)
4. Oil capacity: 323 Gallons
5. Solids/sediment capacity: 295 Gallons
6. Unit weight w/std. covers: 1200 lbs.
7. H2O rated cast iron covers.
8. Maximum operating temperature 140°F continuous.
9. For buried applications only.

ENGINEER SPECIFICATION GUIDE

Striem Oil Tanker™ model OT-750-SS shall be lifetime guaranteed and made in USA of High Density Polyethylene. Separator shall be furnished for below grade installation with field adjustable riser system. Separator flow rate shall be 314 GPM. Separator oil capacity shall be 323 gallons. Sand capacity shall be 295 gallons. Separator shall be certified to IAPMO IGC 183-2016.

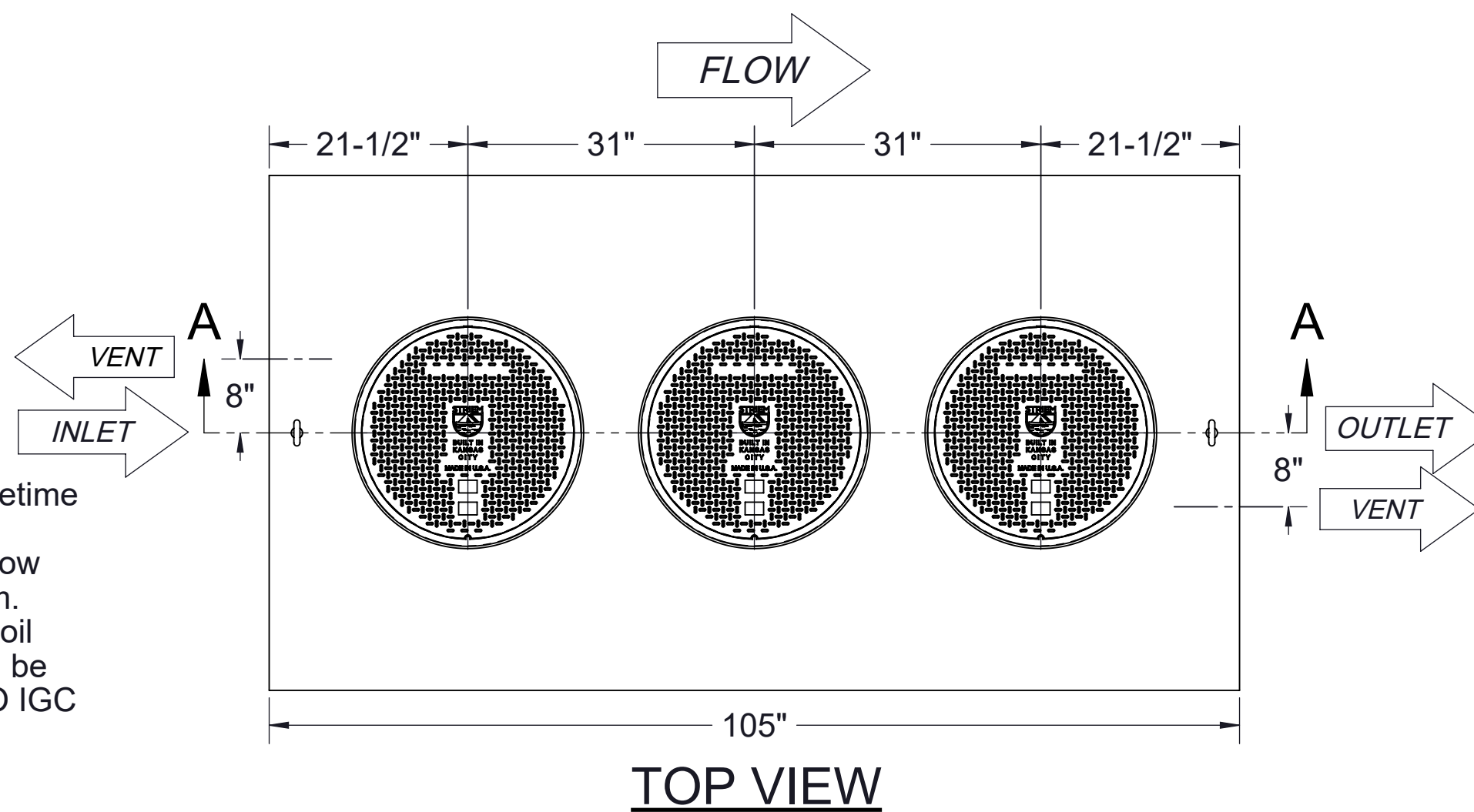

Directions: Choose connections, select options, sign and submit with purchase order.

Connections

- | | |
|--------------------------------------|--|
| Inlet / Outlet | Size |
| <input type="checkbox"/> Plain End | <input type="checkbox"/> 4" |
| <input type="checkbox"/> Male Thread | <input type="checkbox"/> 6" |
| | <input type="checkbox"/> 8" (Plain End Only) |

Riser Options

- Included : 0" - 3"**
- SR24 (3) : >3" - 22"
 - LR24 (3) : >22" - 37"
 - SR24 (6) : >37" - 41"
 - SR24 (3) + LR24 (3) : >41" - 56"
 - LR24 (6) : >56" - 70"
 - SR24 (6) + LR24 (3) : >70" - 88"
 - LR24 (9) : >88" - 104"
- OR -**
- CPRK (3) : >11" - 104"
- See Corrugated Pipe Riser Kit spec for more detail.

Additional Options

- HDK-750 : High Water Table Hold Down Kit

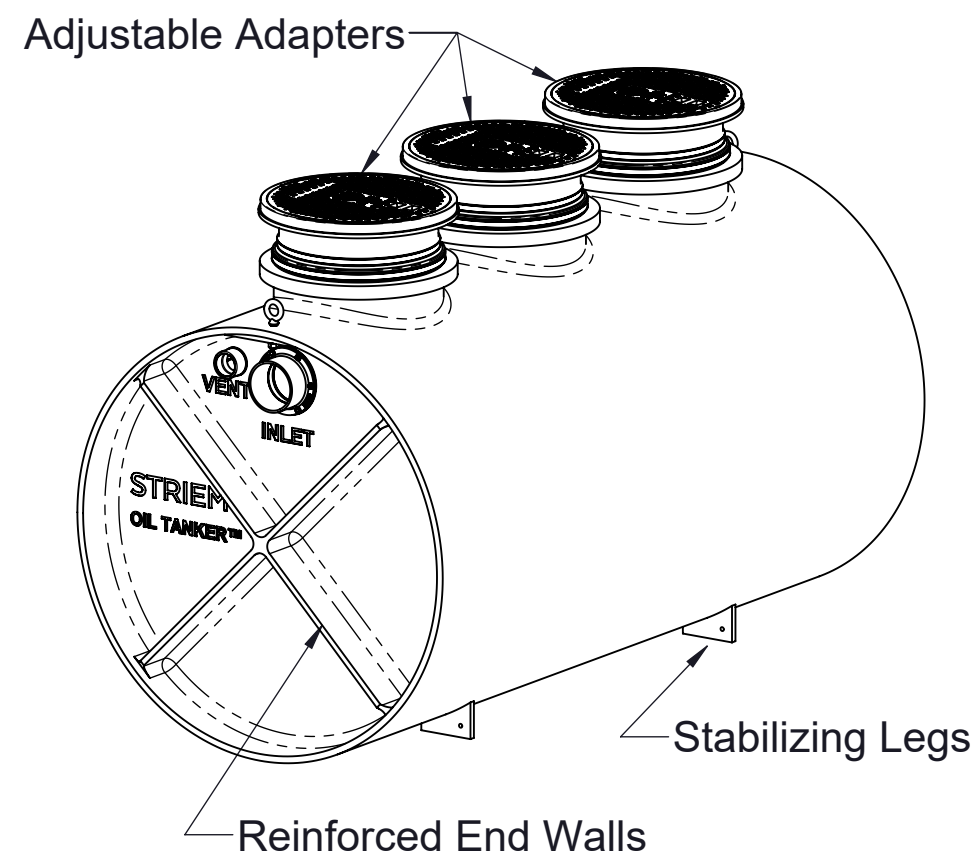

ISOMETRIC VIEW

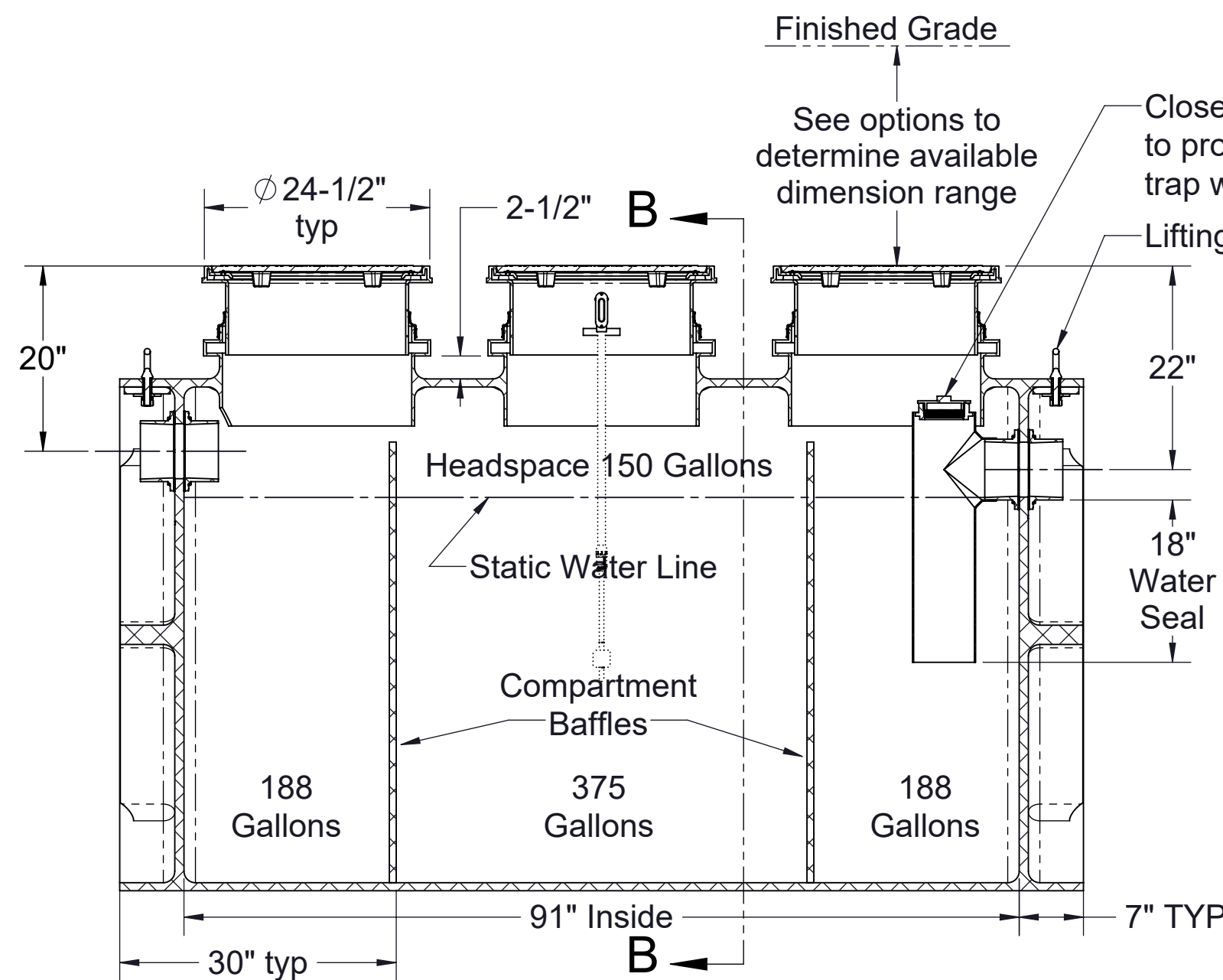

SECTION A-A

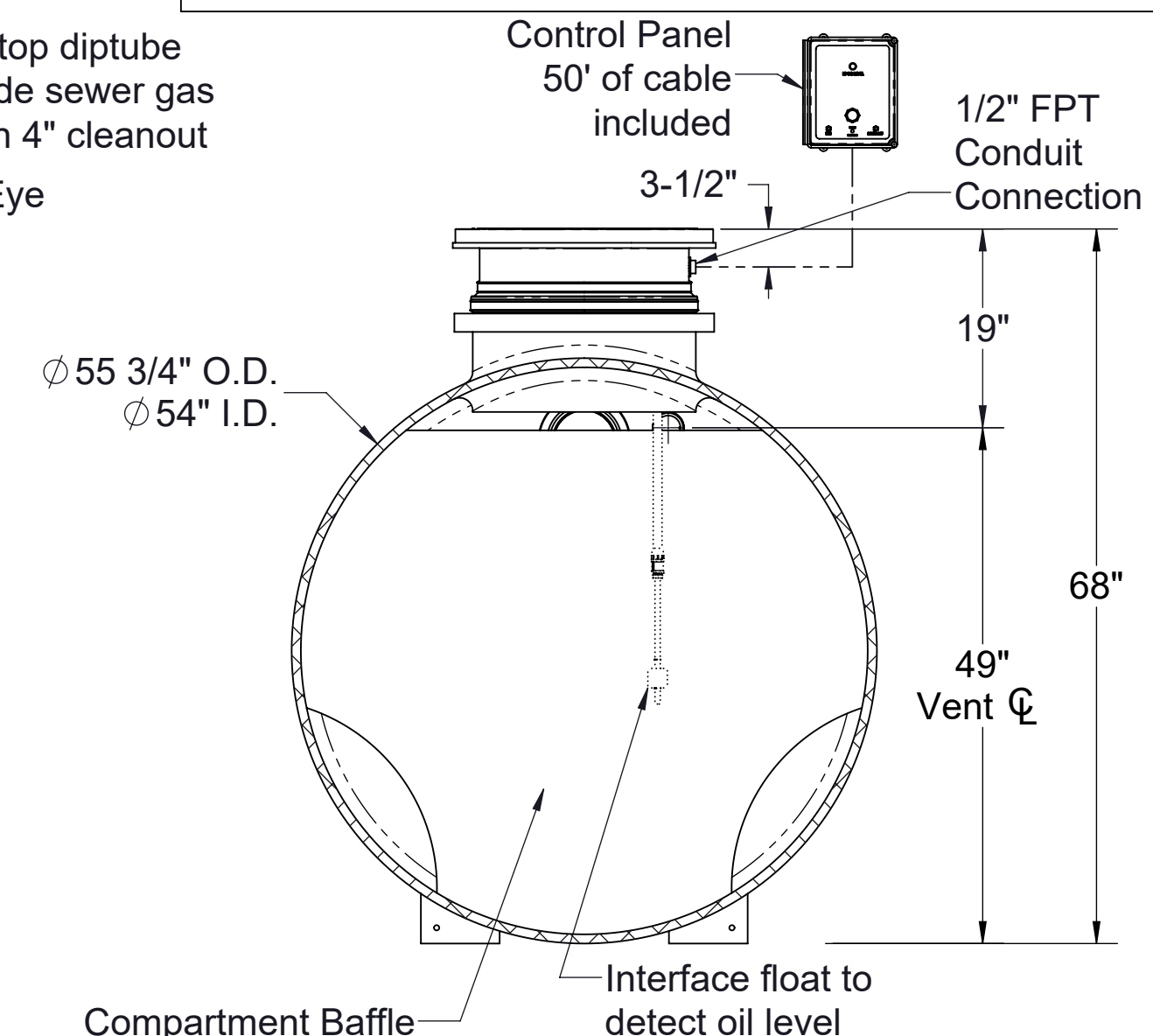

SECTION B-B

Signature of Approval: _____
 Company: _____
 Date of Approval: _____
 Specifying Engineer: _____
 Engineering Firm: _____

PO IS NON-CANCELABLE
 ORDER IS NON-RETURNABLE

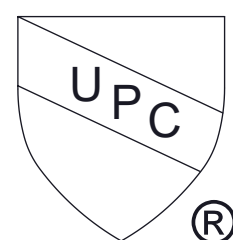

MODEL NUMBER:	OT-750-SS
DESCRIPTION:	OIL TANKER™ WITH SLICK STICK™ OIL LEVEL MONITORING SYSTEM 750 GALLON CAPACITY
DWG BY:	MJ
DATE:	01/15/2021
REV:	0
ECO:	

SPECIFICATION SHEET

Striem
 3100 Brinkerhoff
 Kansas City, KS 66115
 Tel: 913-222-1500
 orders@striemco.com
 www.striemco.com



Made in the U.S.A

PROPRIETARY AND CONFIDENTIAL
 THE INFORMATION CONTAINED IN THIS DRAWING IS THE SOLE PROPERTY OF STRIEM, LLC. ANY REPRODUCTION IN PART OR AS A WHOLE WITHOUT THE WRITTEN PERMISSION OF STRIEM, LLC IS PROHIBITED.